



[Dealer Login](#)



- [Home](#)
- [About Us](#)
- [Products](#)
- [Technical](#)
- [Industrial](#)
- [News](#)
- [Distributors and Stockists](#)
- [Privacy and Conditions](#)
- [Contact Us](#)

- [Latest Developments](#)
- [Subscribe](#)

- [Barton Marine history](#)

Enter Part number or product

technical information

Sail Handling - Slab Reefing Kit Fitting Instructions for Yachts up to 8.5m (2 reefing points) Part No 41484

This system makes reefing your mainsail a quick and easy operation. Just lower the mainsail just below a pre-determined mark on the halyard, attach the reefed clew of the sail onto the reefing hooks (not supplied) at the mast end of the boom and tension the reefing line in and secure. Re-tension the main halyard.

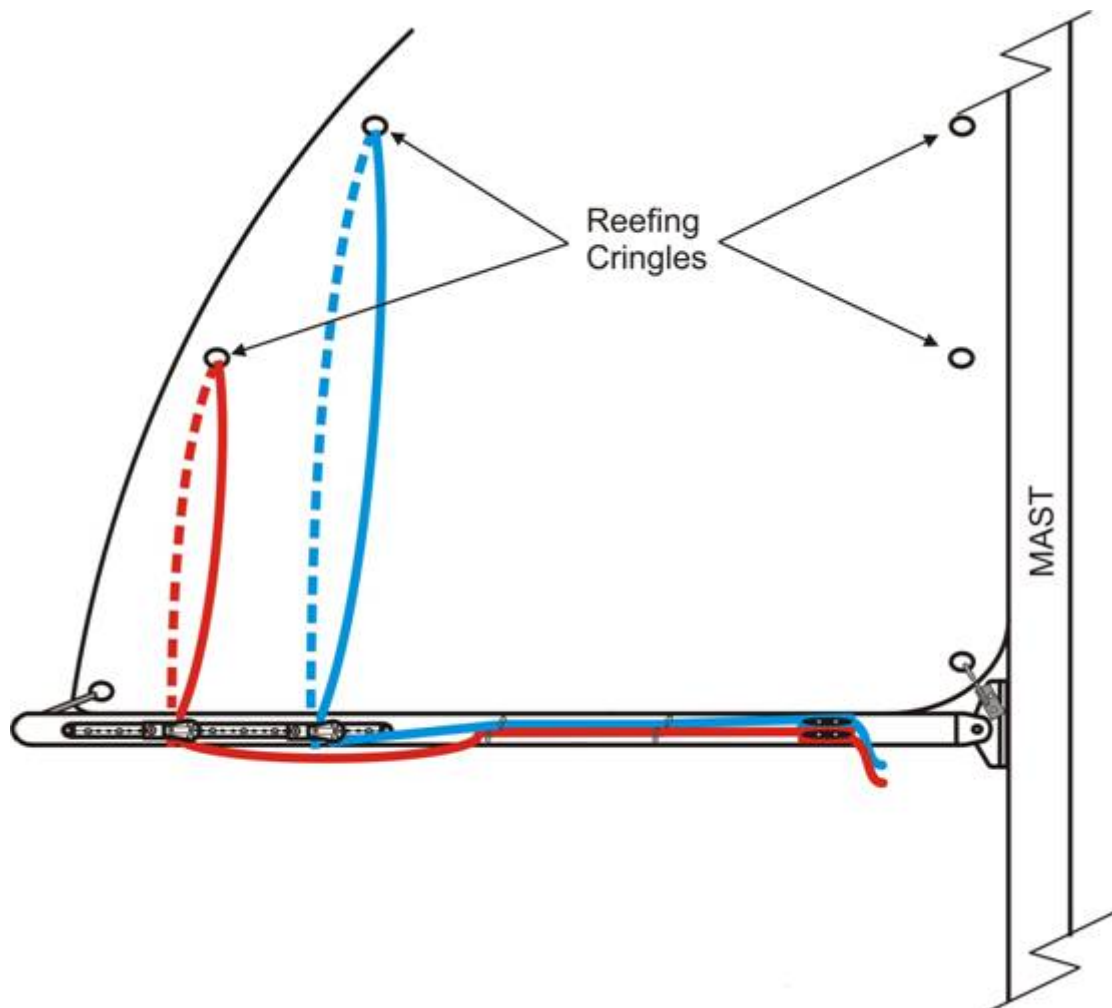

Contents

- 1 x 25mm T Track 60cm length
- 2 x Reefing Sliders (attached to track)
- 1 x Pair Plastic End Caps (attached to track)

Requirements (not supplied)

- M5 x 16mm Countersunk Machine Screws x 8
- Barrier cream (between the stainless steel and aluminium parts)
- 4 x Eye Straps (plus fixings)
- 2 x 8mm line
- 2 x Horn cleats (plus fixings)
- 1 x Reefing hooks (Pr)

Tools

- Pencil
- Hammer
- Cordless Drill
- Screwdriver
- Centre Punch
- Tape Measure
- Hack Saw
- Tape

Drill Bits & Taps

- 4mm Drill Bit
- M5 Tap

We recommend taping all items in place first before drilling any holes and the line to ensure friction is

kept to a minimum.

Port Or Starboard

Decide whether to place the track on the port or starboard side of the boom. Take your time and run through the procedure of reefing before deciding which side to attach the slab reefing kit (if the main halyard winch is attached to the mast it would make life easier to have the slab reefing kit on the same side as the winch). Also how are you going to secure the tack (mast) end on the sail?? We recommend Barton Reefing Hooks, which come in 2 types:

Boom fitting (sold in pairs) – which attach on the boom very close to the gooseneck or Gooseneck Mounting – which attach to the Gooseneck (see “Positioning of Boom Fitting or Gooseneck Hooks)

Positioning The Track On The Boom

The forward end of the track should line up with the position of the secured reefing eye on the sail (highest up the sail, second reef).

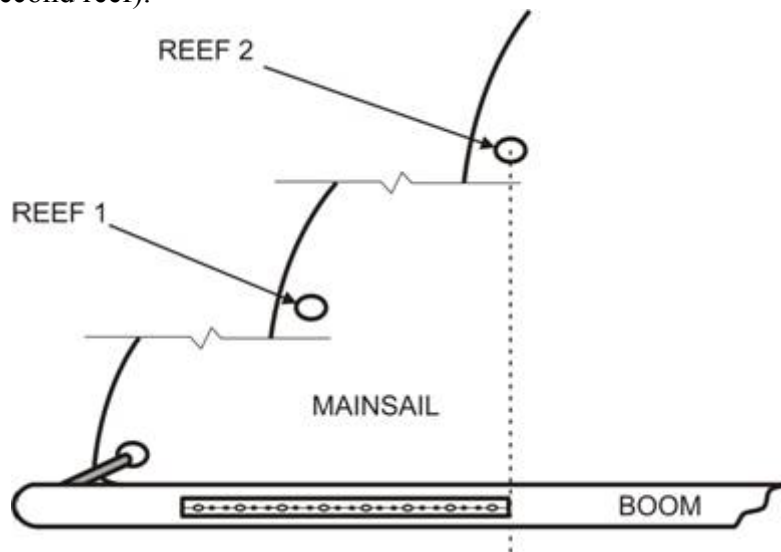

Mounting Track

Ensure the track is at 90° (Y) to the centre line of the boom (X). Position the track and mark first fixing location.

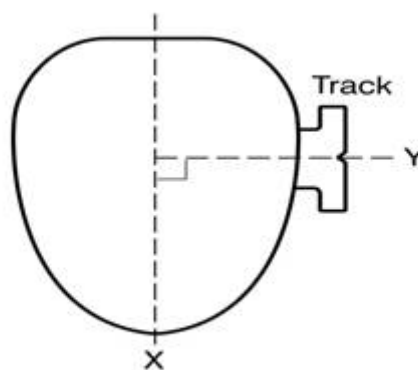

Remove track, drill using 4mm drill and tap using M5 tap then secure in position using M5 machine screw.

Centre punch second fixing hole, loosen screw of first fixing, allow track to pivot away then drill and tap for second fixing. Repeat this procedure until all fixings can be installed. After securing, the screws can be removed and the surplus length inside the boom cut off, to prevent possible snagging of internal

control lines on the sharp ends of the screws. Always use a barrier cream between the stainless steel fixing and the aluminium to prevent corrosion.

Positioning Of The Reefing Sliders

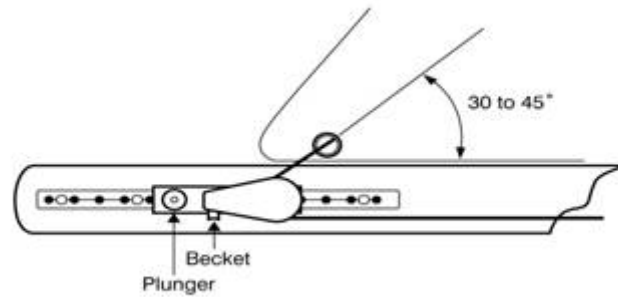

Position the sliders on the track ensuring the plunger end of the slide is aft and the becket on this slide is facing down (this may need to be adjusted depending on whether it is fitted on port or starboard side of the boom. The eye will rotate but may require the use of pliers to carry out this operation).

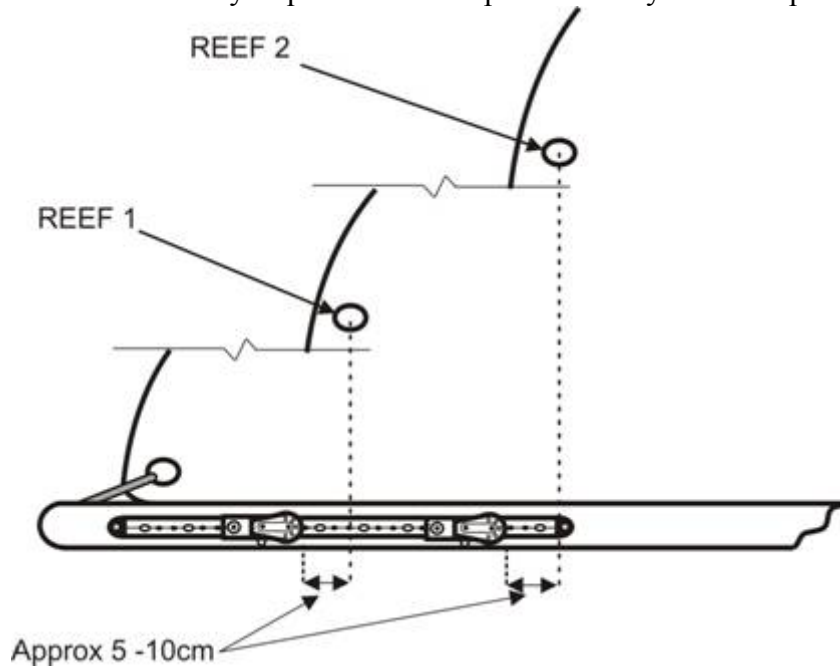

The position of the sliders on the track can be adjusted during a sail trial. The two plastic end caps can now be fitted, ensuring they locate over the end on the track. (This is a push fit) use the centre punch to mark position then remove before drilling and tapping as previously stated.

Positioning Of Boom Fitting Or Gooseneck Hooks (not supplied)

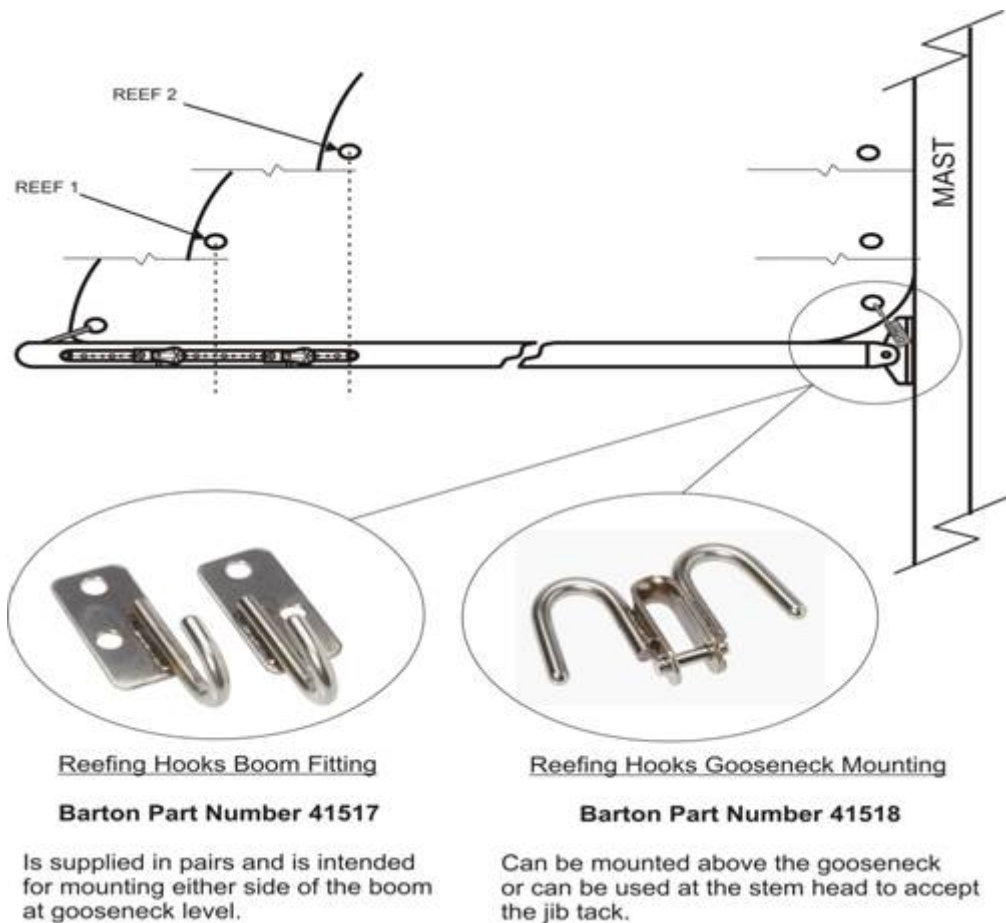

Cleating Off The Reefing Lines (not supplied)

We would recommend using a Horn Cleat (not supplied) to secure the reefing line. This should be fixed near the mast end of the boom (note – push the boom out to the stays to ensure the Horn Cleat will not fail on the stays etc when running down wind.)

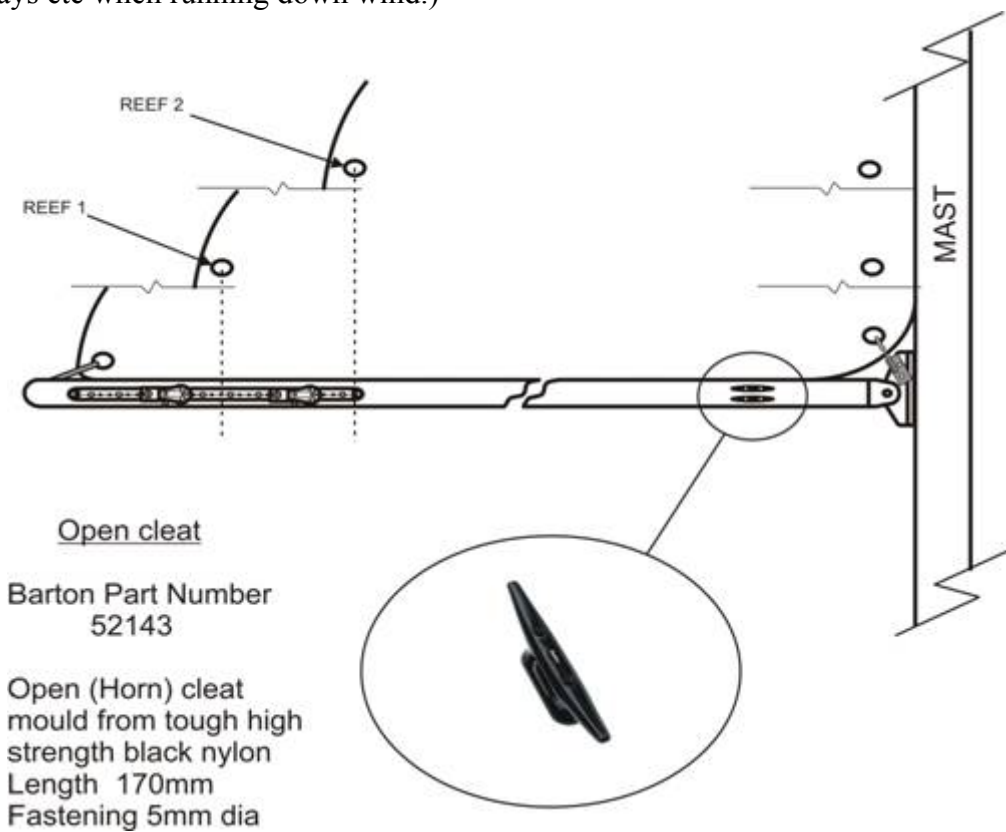

Installing Boom Eye Straps

We would recommend fitting several eyes between the slider and where the reefing line is secure, at approx 1/3 intervals. This will stop the line from sagging, restricting headroom etc, when the slab

reefing kit is not being used.

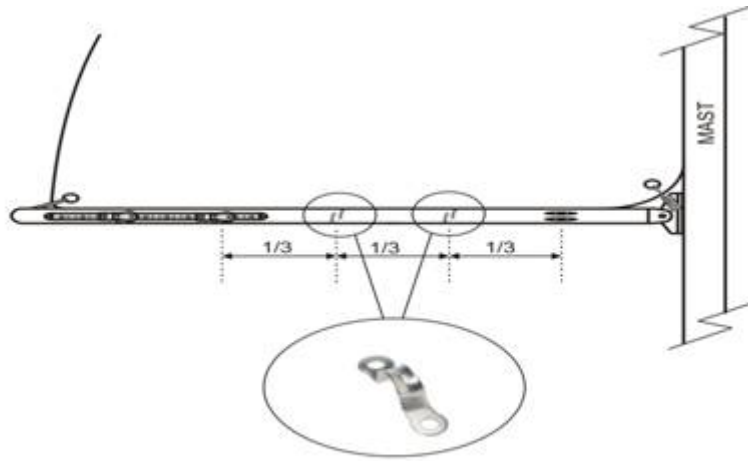

Reeving The Line

8mm line required (not supplied)

The line starts by being tied or spliced to the becket on the bottom of the slide, under the boom up through the eye, down through the sheave on the slide, then forward along the boom through the eyelets and to the Horn Cleat.

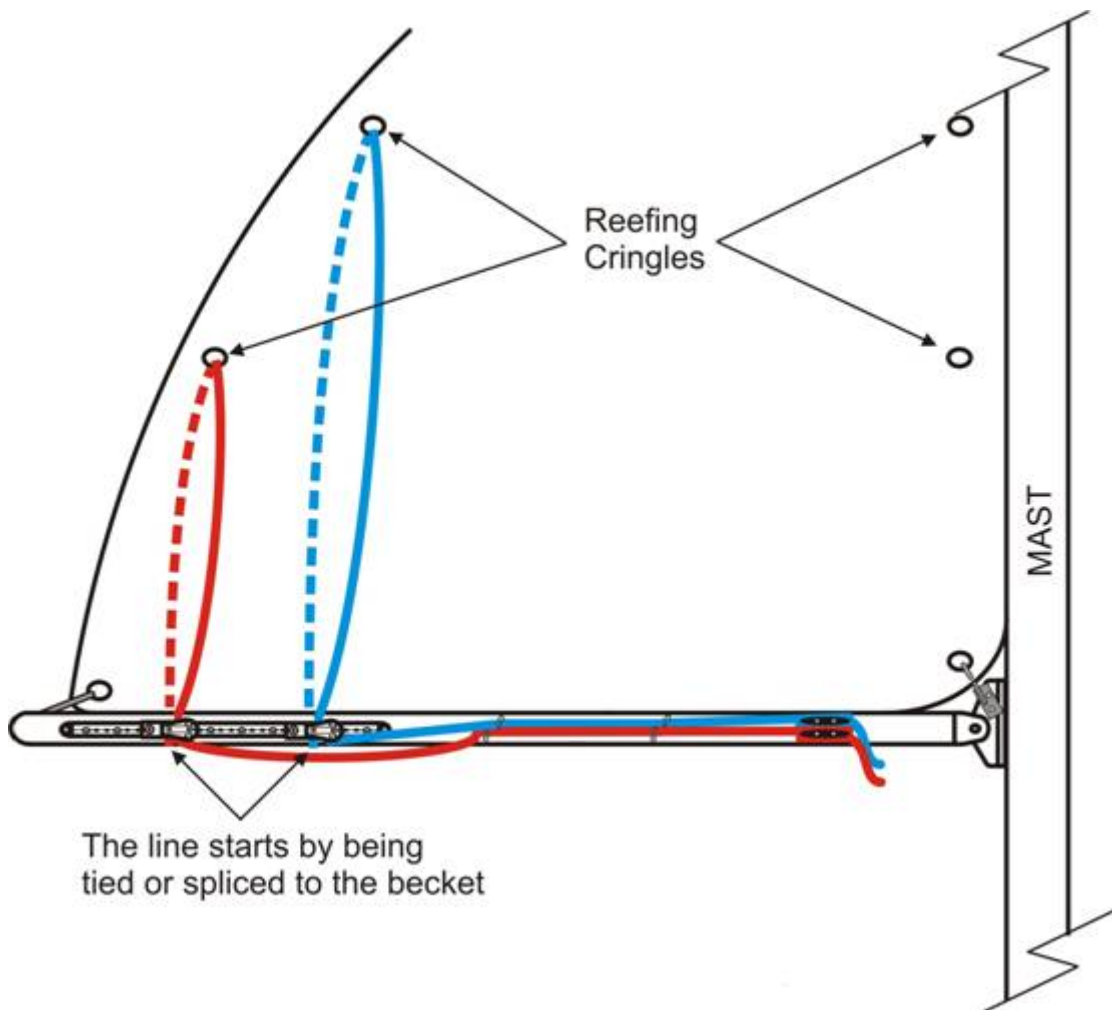

Adjustment

The position of the slider can be altered by lifting the plunger and relocating the slider. It should be positioned so the line leaving the eye in the sail pulls down and aft between 30° and 45°.

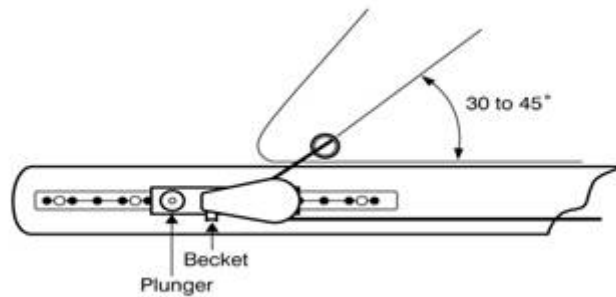

Lower the main Halyard to the correct position for reefing, mark the Halyard at the position of the cleat with permanent marker (reef position 1 +2).

To Reef

Set the Topping Lift, which ensures the boom does not fall accidentally (by using the Barton Boomstrut together with the slab reefing system, this would eliminate the need for a Topping Lift).

Ease the Halyard to just below the marked “Reef” position, pull in the reef line and secure, attach the tack reefing cringle to the reefing hook, then tension the Halyard. The sail is now reefed.

The Barton Slab Reefing System is yet another great product from Barton. A large range of marine hardware for yachts up to 15m (50 foot) is detailed in our catalogue, available on request or by visiting our website www.bartonmarone.com

[Back to Technical Info](#)



Latest Barton News

[Simon Says 1218](#)

[Simon Says 1018](#)

[New Barton Marine Quick Cleat](#)

[Barton Marine New Ratchet Block](#)

Latest Technical Info

- [Quick Cleats](#) **NEW**
- [Ratchet Blocks](#) **NEW**
- [EasySplice demonstration video](#)

- [81 550 Mast Base Organiser](#)
- [Fitting a Removable Barton Traveller System](#)

Associated Companies



Product Catalogue



[Products Catalogue](#)

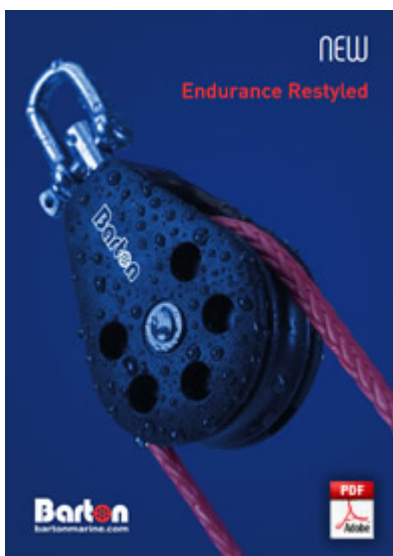

[New Products Supplement](#)

Barton Marine Traditional Blocks

- [Size 0 Traditional Blocks](#)
- [Size 1 Traditional Blocks](#)
- [Size 2 Traditional Blocks](#)
- [Size 3 Traditional Blocks](#)
- [Size 4/5 Traditional Blocks](#)
- [Size 6 Traditional Blocks](#)
- [Size 7 Traditional Blocks](#)

Barton Marine Wooden Classic Blocks



- [Home](#)
- [About Us](#)
- [Products](#)
- [Technical](#)
- [Industrial](#)
- [News](#)
- [Distributors and Stockists](#)
- [Privacy and Conditions](#)
- [Contact Us](#)

- [Latest Developments](#)
- [Subscribe](#)

- [Barton Marine history](#)