

INSTRUCTION BOOK

2010, 2020, 2030, 2040

CALIFORNIA

Proposition 65 Warning

Diesel engine exhaust and some of its constituents are known to the State of California to cause cancer, birth defects, and other reproductive harm.



Welcome aboard

Congratulations on your new boat and your choice of a Volvo Penta marine engine. A choice that will give you many years of sailing pleasure.

Your new marine engine is the result of over 90 years experience in marine engine design, coupled with revolutionary new ideas and concern for the environment, where traditional Volvo Penta qualities such as first class performance, reliability and durability have been upheld. We believe that this also reflects what you require and expect from your new marine engine.

To help you fulfill your expectations, we want you to read through this instruction book carefully, and take our advice about operating and maintaining the engine, before you cast off on your maiden voyage.

Best regards

AB VOLVO PENTA

Contents

Safety Information	3–7	Maintenance schedule	23–24
Introduction	8–9	Maintenance and care	25–51
Running-in	8	Engine, general	25
Fuel and oil types	8	Lubrication system	27
Certified engines	9	Cooling system	28
Warranty and Guarantee information	9	Fuel system	34
Introduction	10–12	Electrical system	36
MD2010, MD2020	10	Wiring diagram	41
MD2030, MD2040	11	S drive and reverse gear	45
Identification numbers	12	Laying up/Launching	49–51
Instrumentation	13–15	Inhibiting	49
Controls	16	Bringing out of storage	50
Starting the engine.	17–19	"Painting the drive and underwater hull"	51
Preparations and starting	17	Fault-tracing	52
Starting the engine using auxiliary batteries	19	Technical Data	53–54
Operation	20–21	General	53
Checking instruments	20	Lubrication, cooling and electrical systems	53
Cruising speed	20	Fuel specification	54
Maneuvering	21	S drive and reverse gear	54
When sailing	21		
Stopping the engine	22		
After stopping the engine	22		
Laying up	22		
Cold weather precautions	22		

Safety Precautions

Read this chapter carefully. It concerns your safety. This chapter describes how safety information is presented in the instruction book and on the engine itself. It also gives a general account of basic safety precautions to be taken when operating the boat and maintaining the engine.

Check that you have the correct instruction book before you read on. If this is not the case please contact your Volvo Penta dealer.



If operations are performed incorrectly this could result in personal injury, or damage to property or the engine. Read the instruction book carefully before operating or servicing the engine. If anything is unclear please contact your Volvo Penta dealer for assistance.

 This symbol is used in the book and on the engine to make you aware of safety information. Always read these safety precautions very carefully.

In the instruction book warning texts have the following priority:

 **WARNING!** If these instructions are not followed there is a danger of personal injury, extensive damage to the product or serious mechanical malfunction.

 **IMPORTANT!** Used to draw your attention to something that can cause damage, product malfunction or damage to property.

NOTE! Used to draw your attention to important information that will facilitate work or operations.

 This symbol is used in certain cases on our products and refers to important information in the instruction book. Ensure that warning and information symbols on the engine and transmission are always visible and legible. Replace symbols that have been damaged or painted over.

Safety precautions to be taken when operating the boat

Your new boat

Read Instruction Manuals and other information supplied with your new boat. Learn to operate the engine, controls and other equipment safely and correctly.

If this is your first boat, or is a boat type with which you are not familiar, we recommend that you practice controlling the boat in peace and quiet. Learn how the boat behaves at different speeds, weather conditions and loads before casting off for your “real” maiden voyage.

Remember that the person driving a boat is legally required to know and follow the current rules regarding traffic and safety at sea. Make sure you know the rules that apply to you and the waters you are sailing in by contacting the relevant authorities or organization.

A good piece of advice is to take a course in seamanship. We recommend that you contact your local boating organization to find a suitable course.

Accidents

Statistics show that poor maintenance of boats and engines and a lack of safety equipment are often the cause of accidents at sea.

Ensure that your boat is maintained in accordance with the relevant Instruction Manual and that the necessary safety equipment is on-board and is serviceable.

Daily checklist

Make a habit of checking the engine and engine compartment visually before operating the boat (**before the engine is started**) and after operating the boat (**after the engine has been stopped**). This will help you to quickly detect fuel, coolant and oil leaks and spot anything else unusual that has, or is about to happen.

Maneuvering

Avoid violent and unexpected changes in course and gear engagement. This could cause someone on the boat to lose their balance and fall over or overboard.

A rotating propeller can cause serious injury. Check that nobody is in the water before engaging ahead or astern. Never drive near bathers or in areas where people could be in the water.

Avoid trimming an outboard drive too much, as steering will be severely reduced.

Refueling

When refueling there is always a danger of fire and explosion. Smoking is forbidden and the engine must be switched off.

Never overfill the tank. Close the fuel tank filler cap properly.

Only use the fuel recommended in the Instruction Manual. The wrong grade of fuel can cause operating problems or cause the engine to stop. On a diesel engine poor quality fuel can cause the control rod to seize and the engine to overrev with a resultant risk of damage to the engine and personal injury.

⚠ Carbon monoxide poisoning

When a boat is moving forward backwash is caused behind the boat. Sometimes this backwash can be so powerful that exhaust gases can be sucked into the cabin or seating well on the boat with the resulting risk of carbon monoxide poisoning for those on board.

The backwash problem is greatest with high, broad boats with a squared stern. But other types of boat can also have backwash problems under certain conditions, for example when running with an awning rigged. Among other factors that can increase the

backwash effect are wind conditions, load distribution, the sea running, trim, open hatches and valves.

Most modern boats are designed in such a way that problems with backwash are extremely unusual. Should a backwash problem occur do not open hatches or valves in the forward part of the boat. This will only increase backwash. Try changing speed, trim or load distribution in the boat instead. In addition take down, open or change the rigging of the awning in some other way if an awning is rigged. Contact the dealer where the boat was purchased to get more information on how to solve this problem should it occur on your boat.

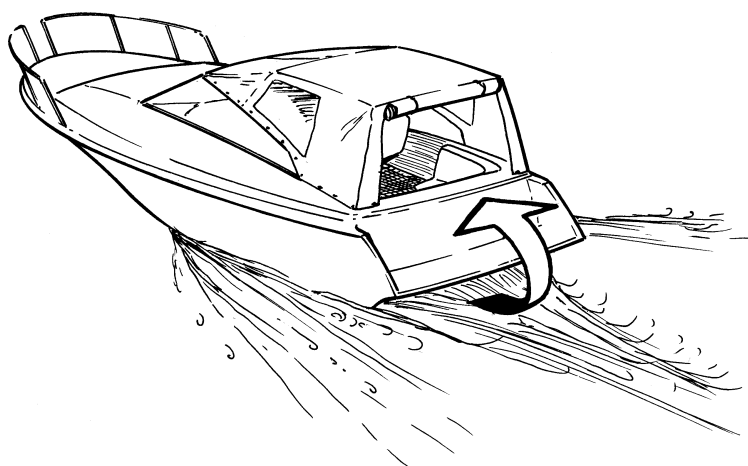

⚠ Checklist

- Safety equipment: Life jackets for all passengers, communication equipment, emergency rockets, approved fire extinguisher, first-aid equipment, life belt, anchor, paddle, torch etc.
- Replacement parts and tools: impeller, fuel filters, fuses, tape, hose clamps, engine oil, propeller and tools for any repairs that might have to be carried out.
- Get out your charts and go over the planned route. Calculate distance and fuel consumption. Listen to the weather reports
- Make sure that relations or contact persons are informed when planning a longer voyage. Remember to inform them if your plans have changed or been delayed.
- Tell your passengers and crew where the safety equipment is stored and how to operate it. Make sure you are not the only person on board who knows how to start the boat and operate it safely.

The list should be supplemented because the requirement for safety equipment varies depending on the boat type and how it is used etc. We recommend that you contact a local boating or maritime safety organization for more detailed marine safety information.

Safety precautions for maintenance and service operations

Preparations

Knowledge

The instruction book contains instructions on how to carry out general maintenance and service operations safely and correctly. Read the instructions carefully before starting work.

Service literature covering more complicated operations is available from your Volvo Penta dealer.

Never carry out any work on the engine if you are unsure of how it should be done, contact your Volvo Penta dealer who will be glad to offer assistance.

Stop the engine

Stop the engine before opening or removing engine hatches. Unless otherwise specified all maintenance and service must be carried out with the engine stopped.

To prevent accidental start of the boat engine remove the ignition key, turn off the power supply to the engine at the main switch and lock it in the OFF position before starting work. Put up a warning sign in the control position that work on the engine is being carried out.

Approaching or working on an engine that is running is a safety risk. Loose clothing, hair, fingers or a dropped tool can be caught in the rotating parts of the engine and cause serious personal injury. Volvo Penta recommend that all servicing with the engine running be undertaken by an authorized Volvo Penta workshop.

Lifting the engine

When lifting the engine use the lifting eyes installed on the engine (reverse gear where installed). Always check that lifting equipment is in good condition and is strong enough for the lift (engine weight with any extra equipment). For safety's sake lift the engine using an adjustable lifting beam. All chains and cables should run parallel to each other and as perpendicular as possible in relation to the top of the engine. Bear in mind that extra equipment installed on the engine may alter its center of gravity. Special lifting equipment may then be required in order to maintain the correct balance and make the engine safe to handle. Never carry out work on an engine suspended on a hoist.

Before starting the engine

Reinstall all guards removed during service operations before starting the engine. Check that no tools or other items have been left on the engine.

Never start a turbocharger engine without installing the air cleaner (ACL). The rotating compressor in the turbocharger can cause serious personal injury. Foreign objects can also be sucked in and cause mechanical damage to the unit.

Fire and explosion

Fuel and lubrication oil

All fuel, most lubricants and many chemicals are inflammable. Read and follow the instructions on the packaging.

When carrying out work on the fuel system make sure the engine is cold. A fuel spill onto a hot surface or electrical components can cause a fire.

Store fuel soaked rags and other flammable material so that there is no danger of them catching fire. In certain conditions oil-soaked rags can spontaneously ignite.

Do not smoke when filling fuel, oil or in proximity of a filling station or in the engine room.

Non-original components

Components used in the fuel and ignition system (gasoline engines) and electrical systems on Volvo Penta products are designed and constructed to minimize the risk of fire and explosion.

Using non-original Volvo Penta parts can result in fire or explosion on board.

Batteries

The batteries contain and give off oxyhydrogen gas, especially during charging. This gas is easily ignited and highly flammable.

Do not under any circumstances smoke or use naked flame or allow sparks in the vicinity of the batteries or battery compartment.

Incorrectly connecting a battery terminal cable or jump-start cable can cause a spark which in turn can be sufficient to cause an explosion.

Start spray

Never use start spray or similar agents to start an engine equipped with air pre-heating (glow plugs/ starter element). The starter element may cause an explosion in the inlet manifold. Danger of personal injury.

⚠ Hot surfaces and fluids

There is always a risk of burns when working with a hot engine. Beware of hot surfaces. For example: the exhaust pipe, turbocharger (TC), oil pan, charge air pipe, starter element, hot coolant and hot oil in oil lines and hoses.

⚠ Carbon monoxide poisoning

Start the engine only in a well-ventilated area. If operating the engine in an enclosed space, ensure that there is proper ventilation in order to remove exhaust gases and crankcase ventilation emissions from the working area.

⚠ Chemicals

Most chemicals such as anti-freeze, rustproofing agent, inhibiting oil, degreasing agent etc. are hazardous to health. Read and follow the instructions on the packaging.

Some chemicals such as inhibiting oil are inflammable and dangerous if breathed in as well. Ensure good ventilation and use a protective mask when spraying. Read and follow the instructions on the packaging.

Store chemicals and other hazardous materials out of the reach of children. To protect the environment please dispose of used or leftover chemicals at a properly designated disposal site for destruction.

⚠ Cooling system

There is a risk of water penetration when working on the seawater system. Turn off the engine and close the sea cock before starting work on the system.

Avoid opening the coolant filler cap when the engine is hot. Steam or hot coolant can spray out and cause burns.

If work must be carried out with the engine at operating temperature and the coolant filler cap or a cock open or a coolant hose disconnected, open the coolant filler cap carefully and slowly to release pressure before removing the cap completely. Note that the coolant may still be hot and can cause burns.

⚠ Lubrication system

Hot oil can cause burns. Avoid skin contact with hot oil. Ensure that the lubrication system is not under pressure before commencing work on it. Never start or operate the engine with the oil filler cap removed, oil can spray out.

⚠ Fuel system

Always use protective gloves when tracing leaks. Liquids ejected under pressure can penetrate body tissue and cause serious injury. There is a danger of blood poisoning.

Always cover the generator if it is located under the fuel filter. The generator can be damaged by spilled fuel.

⚠ Electrical system

Cutting off power

Always stop the engine and break the current using the main switches before working on the electrical system. Isolate shore current to the engine block heater, battery charger, or accessories mounted on the engine.

Batteries

The batteries contain an extremely corrosive electrolyte. Protect your skin and clothes when charging or handling batteries. Always use protective goggles and gloves.

If battery electrolyte comes into contact with unprotected skin wash off immediately using plenty of water and soap. If battery acid comes into contact with the eyes, flush immediately with plenty of water and obtain medical assistance without delay.

Introduction

This instruction book has been compiled to help you get the most from your Volvo Penta engine. It contains all the information you need in order to operate and maintain your engine safely and correctly. **Please read the instruction book carefully and learn how to operate the engine, controls and other equipment safely.**

Always have the instruction book available. Keep it in a safe place and do not forget to give it to the new owner if you sell your boat.

Responsibility for the environment

We all want to live in a clean environment. Where we can breathe clean air, see healthy trees, have clean water in our lakes and oceans and enjoy the sunshine without worrying about our health. Unfortunately this is no longer something we can take for granted, we must work hard together for the environment.

As a manufacturer of marine engines Volvo Penta has a particular responsibility. This is why concern for the environment is one of the cornerstones of our product development. Today great advances have been made in reducing exhaust emissions, fuel consumption and engine noise in Volvo Penta's wide range of engines.

We hope that you will take care to maintain these properties. Always follow the advice in the instruction book about fuel grades, operation and service and you will avoid unnecessary negative impact on the environment. If you notice changes such as increased fuel consumption or exhaust smoke, please contact your Volvo Penta dealer.

Adapt speed and distance so that swell and noise generated by the boat do not disturb or harm wildlife, moored boats, landing stages etc. Leave islands and harbors in the same condition you would like to find them. Always dispose of environmentally harmful waste such as engine and transmission oil, coolant, old paint, degreasing agents, paint and cleaning residue and old batteries at designated disposal areas for destruction.

Together we can work to make a valuable improvement to the environment.

Running-in

The engine must be run in for its first 10 operating hours as follows:

Operate the engine normally. Do not operate it at full load except for short periods. Never run the engine at a constant engine speed for long periods during the running-in period.

The engine can be expected to use more engine oil during the running-in period than would otherwise be normal. Check the oil level more often than is normally recommended.

A First Service Inspection must be carried out after 20-50 running hours. For further information: See the Warranty and Service Book.

Fuel and oils

Only use the fuel and oils recommended in the chapter Technical Data. Other grades of fuel and oil can cause operating problems, increased fuel consumption and, in the long-term, a shorter engine service life.

Always change oil, oil filters and fuel filters at the recommended intervals.

Service and replacement parts

Volvo Penta engines are designed for maximum service life and reliability. They are built to survive in a tough marine environment, but also to cause as little environmental impact as possible. Regular service and the use of Volvo Penta Genuine parts will maintain these properties.

The Volvo Penta worldwide network of authorized dealers are at your service. They are specialists in Volvo Penta products and have accessories and the original replacement parts, test equipment and special tools necessary for high quality service and repair work.

Always follow the maintenance intervals contained in the instruction book. Remember to state the engine/transmission identification number when ordering service and replacement parts.

Certificated engines

If you own an engine certificated for any area where exhaust emissions are regulated by law, the following is important:

Certification means that an engine type is inspected and approved by the authorities. The engine manufacturer guarantees that all engines manufactured of that type correspond to the certified engine.

This places special requirements for maintenance and service as follows:

- The maintenance and service intervals recommended by Volvo Penta must be observed.
- Only genuine Volvo Penta replacement parts may be used.
- The service of injection pumps and injectors or pump settings must always be carried out by an authorized Volvo Penta workshop.

- The engine must not be modified in any way except with accessories and service kits approved by Volvo Penta.
- No modifications to the exhaust pipes and air supply ducts for the engine may be undertaken.
- Seals may only be broken by authorized personnel.

Otherwise the general instructions contained in the instruction book concerning operation, service and maintenance must be followed.

⚠ IMPORTANT! Late or inadequate maintenance/ service or the use of spare parts other than Volvo Penta original spare parts will invalidate AB Volvo Penta's responsibility for the engine specification being in accordance with the certificated variant.

Volvo Penta accepts no responsibility or liability for any damage or costs arising due to the above.



Warranty

Your new Volvo Penta marine engine is covered by a limited warranty according to the conditions and instructions contained in the Warranty and Service book.

Note that AB Volvo Penta's liability is limited to that contained in the Warranty and Service Book. Read this book as soon as you take delivery of the engine. It contains important information about warranty cards, service and maintenance which you, the owner, must be aware of, check and carry out. Liability covered in the warranty may otherwise be refused by AB Volvo Penta.

Contact your Volvo Penta dealer if you have not received a Warranty and Service Book and a customer copy of the guarantee card.

Presentation

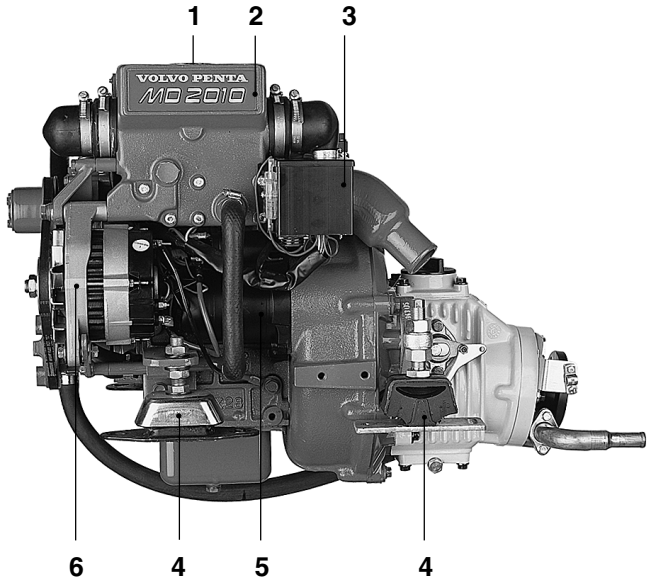

MD2010 with reverse gear MS2L

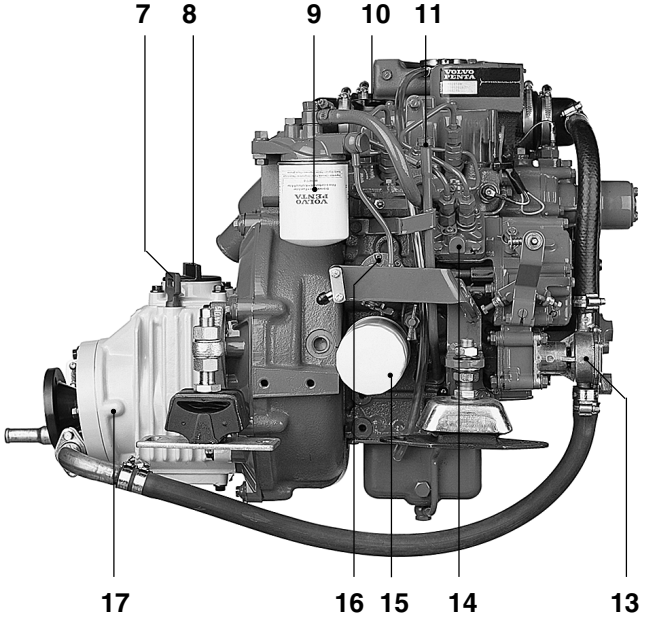

MD2010 with reverse gear MS2L

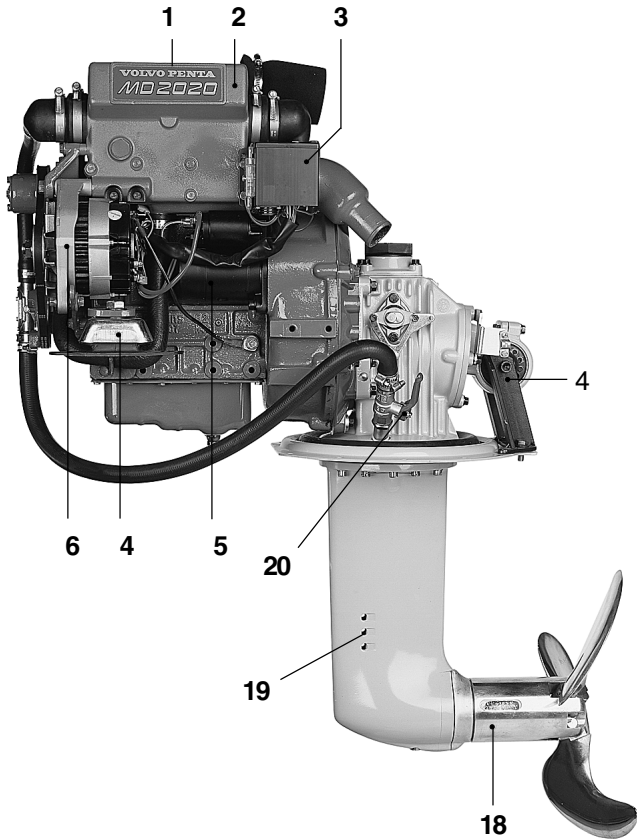

MD2020 with sailing boat drive 120S

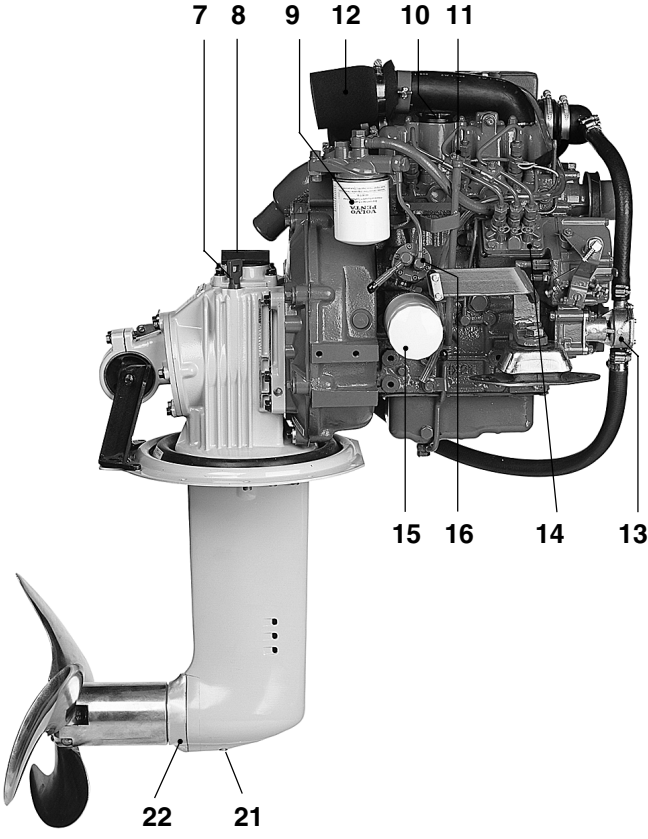

MD2020 with sailing boat drive 120S

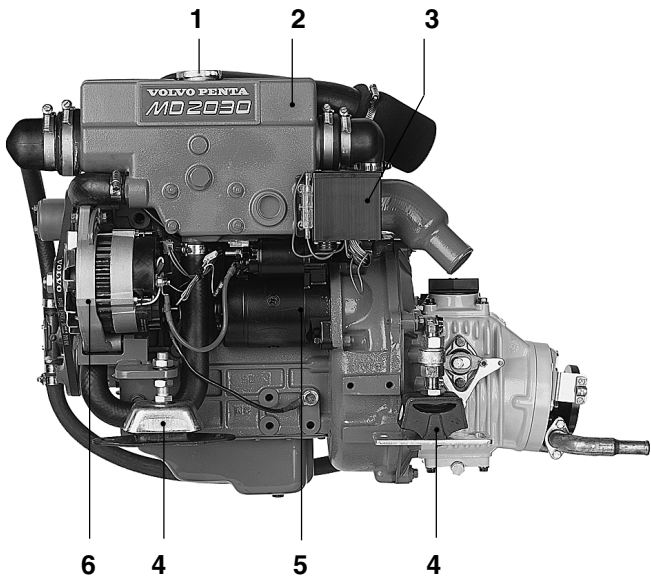

MD2030 with reverse gear MS2A

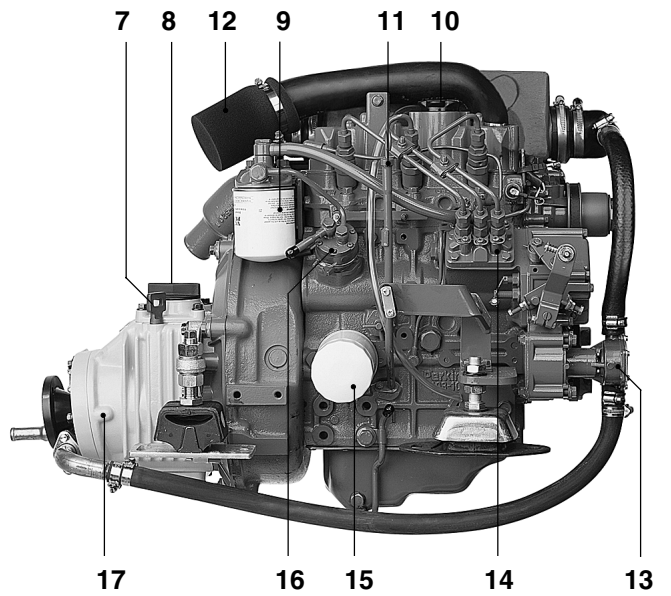

MD2030 with reverse gear MS2A

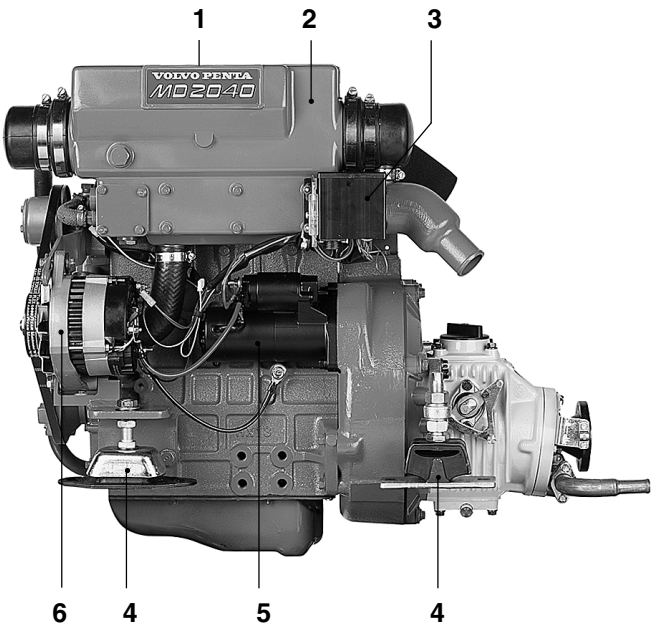

MD2040 with reverse gear MS2L

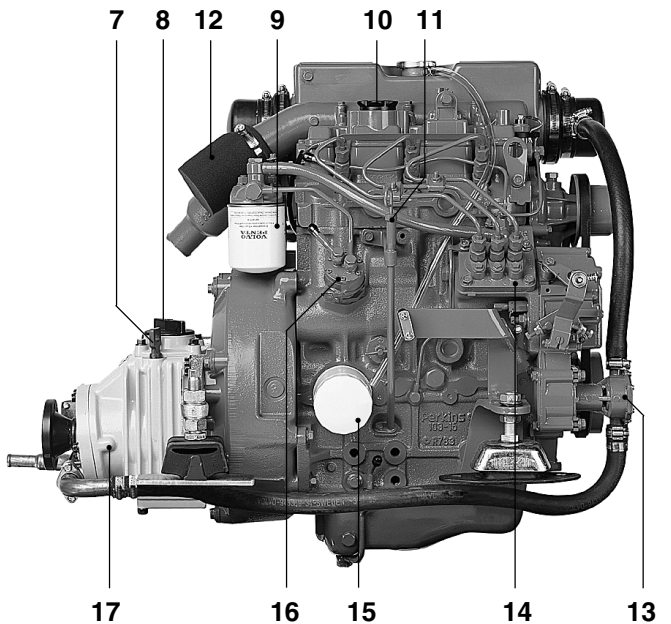

MD2040 with reverse gear MS2L

1. Coolant filler cap
2. Expansion tank
3. Relay box with fuses
4. Flexible mounting
5. Starter motor
6. AC generator
7. Dipstick, reverse gear/S-drive
8. Oil filler cap, reverse gear/S-drive

9. Fine fuel filter
10. Oil filler cap, engine
11. Dipstick, engine
12. Air cleaner (ACL)/Air intake
13. Seawater pump
14. Injection pump
15. Lubricating oil filter
16. Fuel pump

17. Oil cooler, reverse gear
18. Folding propeller
19. Cooling water intake, S-drive
20. Sea cock, S-drive
21. Oil drain plug, S-drive
22. Sacrificial anode

Identification number

Your engine and transmission has identification plates with identification numbers. This information should always be quoted when ordering service and replacement parts. There are probably similar plates on your boat and its equipment. Make a note of the details below, make a copy of the page and keep it so that you have a copy should the boat be stolen.

The appearance and location of identification plates is shown below. The figures in brackets refer to the location of the identification numbers on the identification plate.

Engine

Product designation (1)

Serial number (2)

Product number (3)

Certification number (4)

S-drive/Reverse gear

Product designation (5)

Serial number (6)

Product number (7)

Gear ratio (8)

Propeller designation

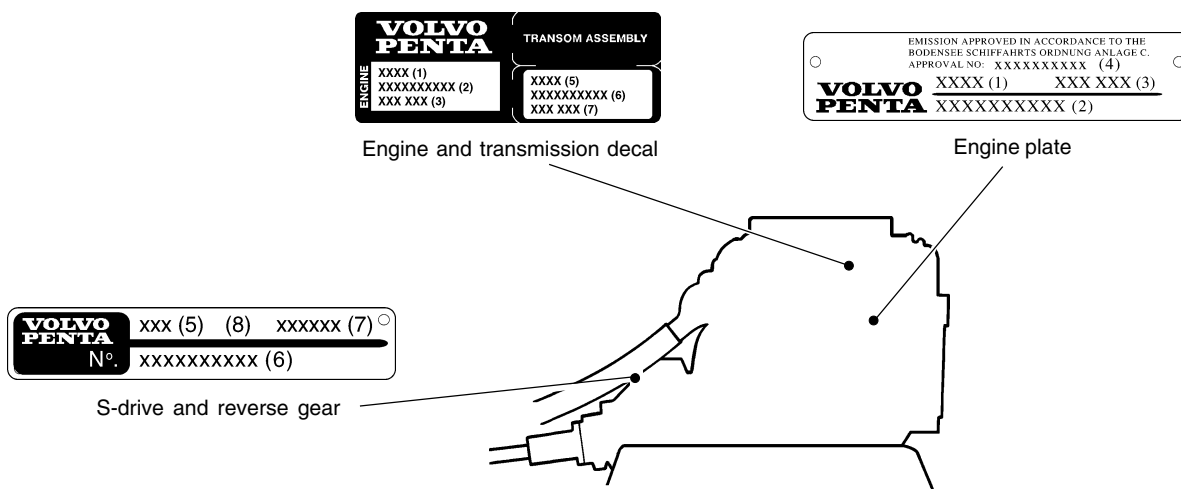

Instrumentation

This chapter only describes the instrument panels available as standard alternatives for your engine from Volvo Penta. Note that in certain boats instruments, alarm panels, key switches etc. may be installed separately without the instrument panels shown here.

If you want to install additional instrumentation, or your boat is equipped with instruments not described here, please contact your Volvo Penta dealer.

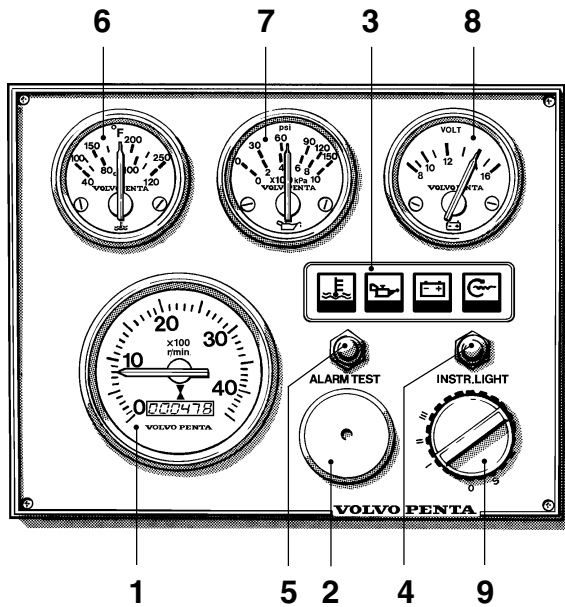

Instrument panel with ignition switch

1. Tachometer and hour counter (accessory). Displays engine speed. Multiply this value by 100 for revolutions per minute. The hour counter displays engine operating time in hours and tenths of an hour.
2. Siren for acoustic alarm.
3. Warning display. See 16-19.
4. Switch for instrument lighting.
5. Alarm test/acknowledgment switch.

To test alarm: Press the switch. All warning lights light and the acoustic alarm sounds.

Alarm acknowledgment: Press the switch if there is an alarm. The acoustic alarm stops but the relevant warning lamp continues to flash until the malfunction is corrected.

6. Temperature gauge. Displays the engine coolant temperature.
7. Oil pressure gauge. Displays the oil pressure in the engine.
8. Voltmeter. Displays the charge voltage from the generator.
9. Ignition switch. See description in the next chapter.

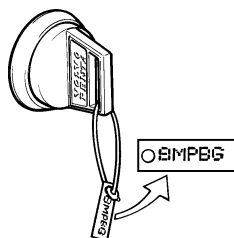
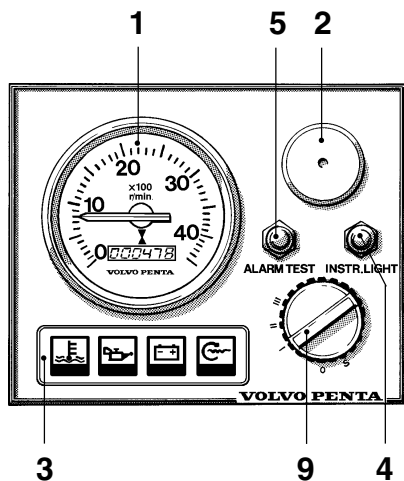

Ignition switch

The starter keys are tagged with a key code. This code must be quoted when ordering extra keys. Keep the code where it is **not** available to unauthorized persons.

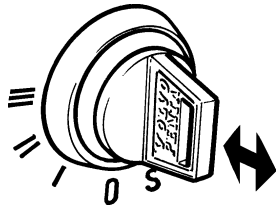

- S = The mechanical restart inhibitor is disengaged. The key springs back automatically to the 0 position.
- 0 = The key can be inserted and removed.
- I = Operating position.
- II = Glow plug position. The glow plugs are connected and pre-heating the engine.
- III = Start position. The starter motor is engaged.

⚠ IMPORTANT! Read the starting instructions in the chapter: Starting the engine.

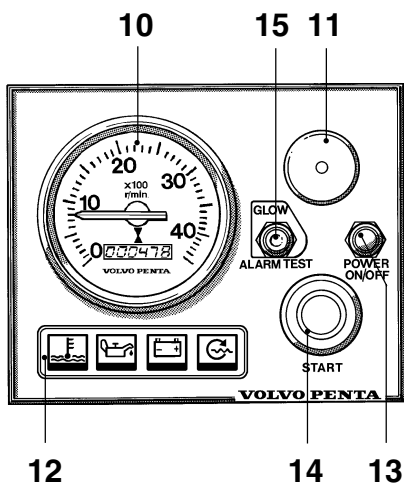

Instrument panel without ignition switch

The instrument panel does not have an ignition switch. To stop unauthorized persons starting the engine the wheelhouse should have a lock or a lockable main switch should be used.

- 10. Tachometer and hour counter (accessory). Displays engine speed. Multiply this value by 100 for revolutions per minute. The hour counter displays engine operating time in hours and tenths of an hour.
- 11. Siren for acoustic alarm.
- 12. Warning display. See 16-19.
- 13. Switch for connecting and disconnecting instrument panel.
- 14. Starter button. The starter motor is engaged when this button is pressed.
- 15. Alarm test/acknowledgment and glow plug rocker switch.

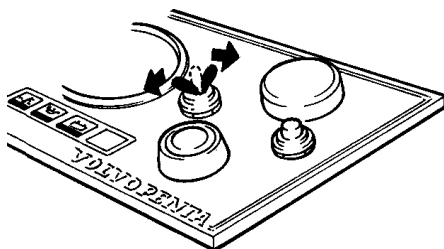

Glow plugs active: When the rocker switch is in the up position the glow plugs are activated.

To test alarm: Move the rocker switch down. All warning lights light and the acoustic alarm sounds.

Alarm acknowledgment: If there is an alarm the rocker switch is moved down and the alarm is acknowledged. The acoustic alarm stops but the relevant warning lamp continues to flash until the malfunction is corrected.

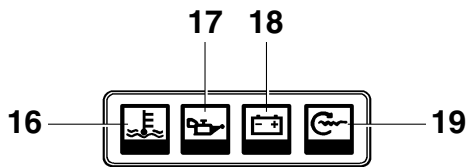

Warning display

If the acoustic alarm sounds, one of the three warning lamps (16-18) on the instrument panel starts to flash to indicate the source of the alarm.

16. Engine coolant temperature too high.

⚠ IMPORTANT! If the alarm sounds: Reduce engine speed to idle (neutral). Stop the engine if the temperature does not drop. Investigate and correct the malfunction.

17. Low oil pressure.

⚠ IMPORTANT! If the alarm sounds: Stop the engine immediately and investigate.

18. Generator not charging.

19. Indicator lamp Comes on when the glow plugs are activated.

Check that the warning lamps are operating before starting the engine according to the description of the relevant instrument panel.

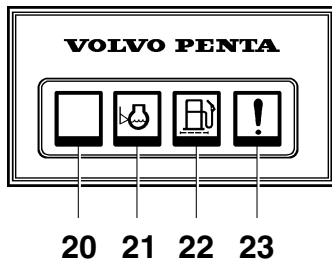

Extra warning display

If the acoustic alarm sounds, one of the four warning lamps starts to flash to indicate the source of the alarm. The extra warning display is an accessory.

20. Not used.

21. Low coolant level. Top up to correct level before starting.

22. Water in extra fuel pre-filter. Drain off water in filter. See instructions in the chapter Maintenance.

23. Extra alarm for an optional function.

Controls

The shift function and engine speed control are combined in one lever. If necessary the shift function can be easily disengaged so that only the engine speed (rpm) is affected by the lever. The control lever has an adjustable friction brake. A neutral position switch is available as an accessory, this will only permit the engine to be started with the drive/reverse gear disengaged.

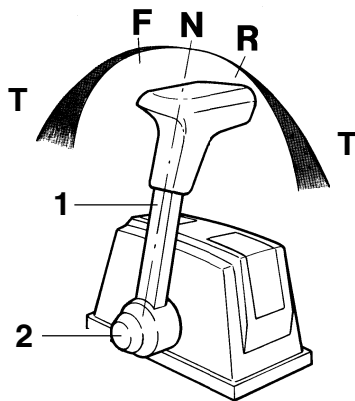

For top-mounted controls

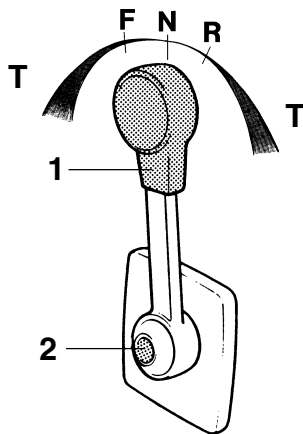

For side-mounted controls

Maneuvering

Shifting and engine speed are controlled with the same lever (1).

N = Neutral position. Drive/reverse gear disengaged.

F = Drive/reverse gear engaged for movement ahead.

R = Drive/reverse gear engaged for movement astern.

T = Engine speed control

Disengaging the shift function

- Move lever (1) to the neutral position (N).
- Press in button (2), move the lever slightly forward and release the button.

The shift function is now disengaged and the lever affects only engine speed. When the lever is moved back to the neutral position it will automatically re-engage.

⚠ IMPORTANT! Take care not to engage the drive/reverse gear by mistake.

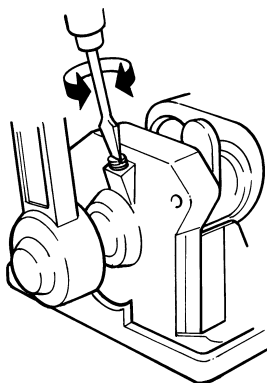

Adjusting the friction brake

The friction brake only affects the engine speed control movements.

- Lift the cover over the control. For side-mounted controls the lever must first be removed.
- Set the lever to the half-open throttle/reverse position.
- Adjust the friction brake. Turning the screw clockwise (+) makes the lever movement stiffer, while turning counterclockwise (-) makes it easier to move the lever.
- Reinstall the cover and lever.

Starting the engine

Make a habit of checking the engine and engine compartment visually before operating the boat. This will help you to quickly detect anything unusual that has or is about to happen. Also check that instruments and the warning display are indicating normal values when you have started the engine.

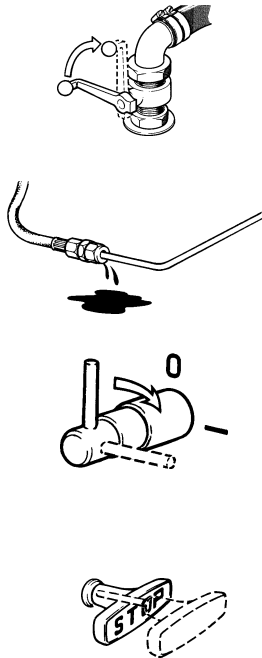

Before starting

- Open the cooling water intake sea cock.
- Open fuel cock.
- Check that there are no fuel, engine coolant or oil leaks.
- Check oil and engine coolant levels in the engine. See chapter: Maintenance.
- Switch on the main switch.
 - ⚠ **IMPORTANT!** Never break the circuit with the main switch while the engine is running. This could damage the generator.
- Start the engine compartment fan if one is fitted and let it run for at least four minutes.
- Check that there is sufficient fuel.
- Push in the stop control.

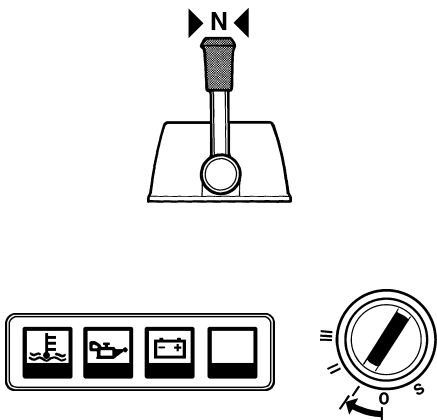

Starting. Instrument panel with ignition lock

⚠ **WARNING!** Never use start spray or similar to start the engine. Danger of explosion!

1. Move the control lever to the neutral/idle position.
2. Insert the key in the ignition switch. Turn key to the "I" position. The three warning lamps come on and can be checked.

Check that the acoustic alarm is operating by pressing the "Alarm Test" button.

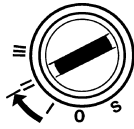
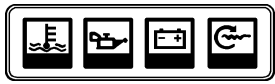

3. Turn key to the "II" position. The indicator light comes on and the glow plugs are connected to pre-heat the engine. Let the glow plugs remain activated for 10 seconds (max. 30 seconds).

⚠ IMPORTANT! Always pre-heat the engine (even when it is at operating temperature).

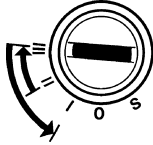
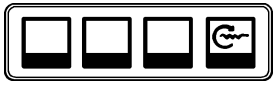

4. Turn the key to position "III" to start. Release the key as soon as the engine has started, the key will automatically spring back to the "I" position. If the engine did not start the key must first be turned to the "0" position before trying again.

⚠ IMPORTANT! If the starter motor is engaged for its maximum engagement time (20-30 seconds) let it cool down for five minutes before trying to start the engine again.

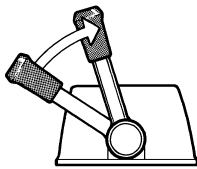

5. Warm up the engine at low speed and low load.

⚠ IMPORTANT! Do not race the engine while it is cold.

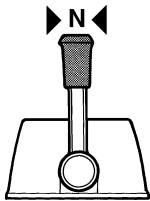

Starting. Instrument panel without ignition switch

⚠ WARNING! Never use start spray or similar to start the engine. Danger of explosion!

1. Move the control lever to the neutral/idle position.
2. Activate the instrument panel by pressing the "Power ON/OFF" switch. The three warning lamps come on and can be checked.

Check that the acoustic alarm is operating by pushing the rocker switch to the "Alarm Test" position.

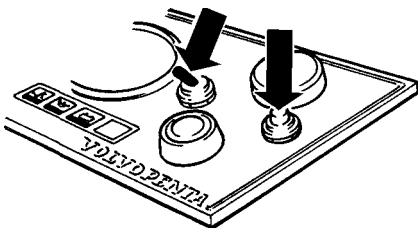

3. Push the rocker switch to the "Glow" position. The indicator light comes on and the glow plugs are connected to pre-heat the engine. Let the glow plugs remain activated for 10 seconds (max. 30 seconds).

⚠ IMPORTANT! Always pre-heat the engine (even when it is at operating temperature).

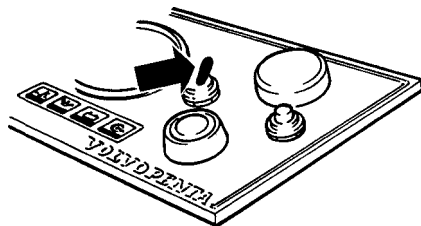

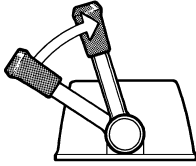
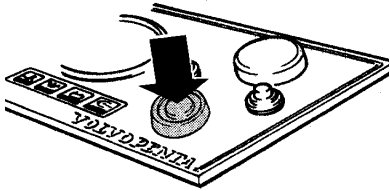

4. Press the starter button. Release the starter button as soon as the engine starts.

⚠ IMPORTANT! If the starter motor is engaged for its maximum engagement time (20-30 seconds) let it cool down for five minutes before trying to start the engine again.

5. Warm up the engine at low speed and low load.

⚠ IMPORTANT! Do not race the engine while it is cold.

Starting using auxiliary batteries

⚠ WARNING! Batteries produce oxyhydrogen. This gas is easily ignited and highly volatile. A short-circuit, naked flame or spark can cause a large explosion. Ensure that the ventilation is good.

Never mix up battery positive and negative terminals. This may cause sparks and an explosion.

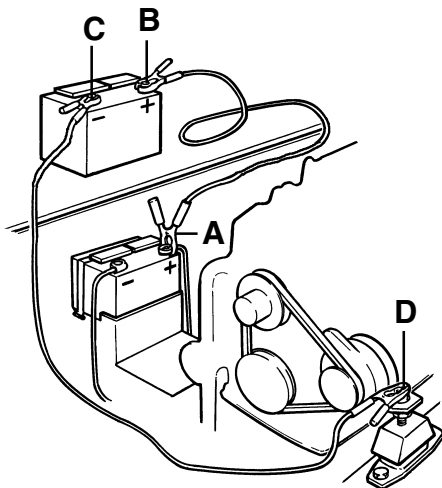

1. Check the auxiliary batteries have the same rated voltage as the engine's system voltage.
2. First connect the red jump lead to the discharged battery's **+ terminal (A)** and then to the auxiliary battery's **+ terminal (B)**.
3. First connect the black jump lead to the auxiliary battery's **- terminal (C)** and then to a site **(D)** where there is good contact with the cylinder block as far away from the discharged battery as possible.

4. Start the engine and run it at a fast idle for approximately ten minutes to charge the battery.

⚠ WARNING! Approaching or working on a running engine is dangerous. Watch out for rotating components and hot surfaces.

Do not touch the connections while trying to start the engine: This may cause sparks. Do not lean over the batteries.

5. Stop the engine. Remove the jump leads in **exactly** the opposite order to which you put them on.

Operation

Avoid violent and unexpected changes in course and gear engagement. There is a risk that someone aboard will fall over or overboard.

⚠ WARNING! A rotating propeller can cause serious injury. Check that nobody is in the water before engaging ahead or astern. Never drive near bathers or in areas where people could be in the water.

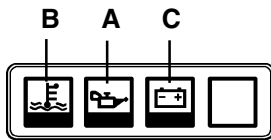

Checking instruments

Check the instruments and warning display directly after starting the engine and then at regular intervals while driving the boat. Stop the engine if there is an abnormal reading or any warning lamp comes on and the alarm sounds. For engines with measuring instruments the following standard values apply:

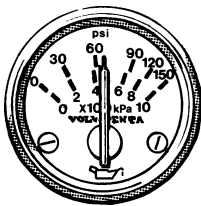

Oil pressure (A)

Normal operating oil pressure is between 150-500 kPa (21-71 psi). At engine idle this is normally lower. The acoustic alarm will automatically go off if the oil pressure is too low.

⚠ IMPORTANT! If the alarm sounds: Stop the engine immediately. Investigate and correct the malfunction.

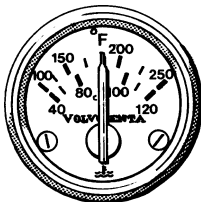

Engine coolant temperature (ECT) (B)

Normal operating temperature is between 75-90°C. The acoustic alarm will automatically go off if the engine coolant temperature (ECT) is too high.

⚠ IMPORTANT! If the alarm sounds: Reduce engine speed to idle (neutral). Stop the engine if the temperature does not drop. Investigate and correct the malfunction.

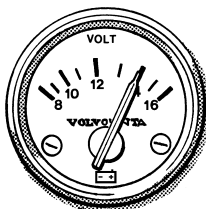

Charging (C)

The operating charge current is approx. 14 V. When the engine is stopped battery voltage is approx. 12 V.

Cruising speed

Operating the engine at wide open throttle (WOT) should be avoided since it is both uneconomical and uncomfortable. Volvo Penta recommends a cruising speed in the range 300 - 500 rpm lower than maximum rpm at WOT. Depending on hull type, choice of propeller, load and conditions etc. the maximum engine speed at top speed can vary, but it should be within the WOT range.

Wide Open Throttle (WOT) range:

MD2010-2040 3,200-3,600 rpm

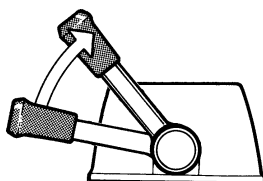

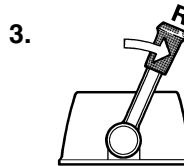
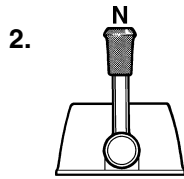
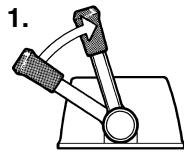

Maneuvering

All shifting between ahead and astern must be done at engine idle speed. Shifting at higher speeds may damage the drive or reverse gear and will also be uncomfortable for those on board.

1. Reduce engine speed to idling and, if possible, let the boat lose most of its speed.
2. Move the reverse gear control lever quickly and firmly into the neutral position. Wait for a moment.
3. Move the gear control lever quickly and firmly into astern, then increase the speed.

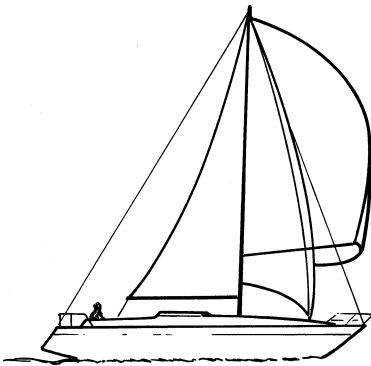

When sailing

If the boat has a fixed propeller the control lever must be in the neutral position when sailing. If the boat has a folding propeller the control lever must be in the astern position.



IMPORTANT! If you are sailing far, run the engine every 10 hours if the boat has a fixed propeller. This is to ensure the drive/reverse gear is lubricated and cooled. If this is not possible then a propeller shaft brake must be installed.

Stopping the engine

The engine should be run for a few minutes at idle (in neutral) before turning it off. This will avoid boiling and even out the temperature. This is especially important if the engine has been operated at high engine speeds and loads.

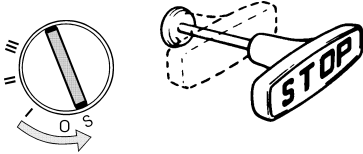

Stopping

Pull and hold out the stop control until the engine has stopped. Push in the stop control. If the instrument panel has an ignition switch the key should be turned to the stop position "S". The key will automatically spring back to the "0" position when it is released and can then be removed.

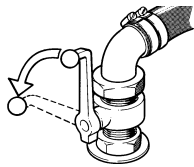
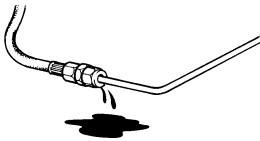

After stopping the engine

- Inspect the engine and engine compartment for any leaks.

- Close the fuel cock and sea cock for the cooling water intake.

⚠ IMPORTANT! Do not forget to open the cocks before the engine is started again.

- Switch off the main switch if the boat is not to be used for some time.

⚠ IMPORTANT! Never break the circuit with the main switches while the engine is running. This could damage the generator.

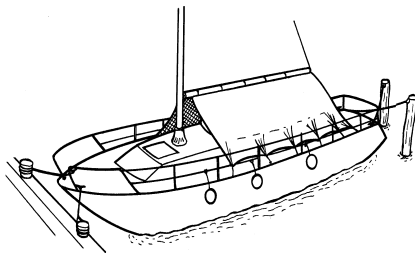

Laying up

If the boat is not going to be used for some time but is being left in the water, the engine must be run to operating temperature at least once every 14 days. This prevents corrosion in the engine. If the boat will not be used for more than two months then inhibiting should be carried out: See chapter "Laying up/Launching".

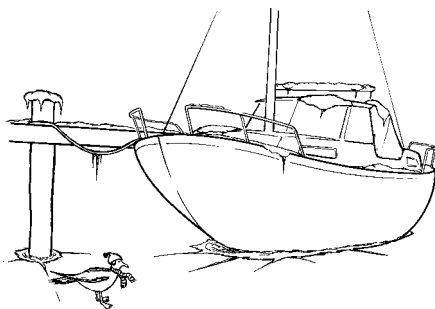

Cold weather precautions

To prevent freezing damage, the seawater system must be drained and the freshwater system coolant must have sufficient antifreeze protection. See chapter Maintenance "Cooling systems".

⚠ IMPORTANT! A poorly charged battery may burst as a result of freezing.

Maintenance schedule

Your Volvo Penta engine and its transmission is designed for maximum service life and reliability. They are built to survive in a tough marine environment, but also to cause as little environmental impact as possible. Regular maintenance according to the following schedule is necessary if the engine and transmission are to operate without problems.

 **WARNING!** Read the chapter on Maintenance carefully before starting work. It contains instructions on how to carry out the work safely and correctly.

 **IMPORTANT!** Service operations marked must be carried out by an authorized Volvo Penta Service workshop.

DAILY BEFORE STARTING FOR FIRST TIME

- Engine oil. Checking level page 27
- Coolant. Checking level page 29
- Leakage check. Engine and engine compartment not shown

EVERY 14 DAYS

- Fuel pre-filter. Drain water page 35
- Drive belt. Check page 25
- Seawater filter. Cleaning page 33
- Battery. Check electrolyte level page 37
- Reverse gear. Check oil level page 45
- S-drive. Check oil level page 45

AFTER THE FIRST 20–50 OPERATING HOURS

- First Service inspection not shown ¹⁾

¹⁾ A first Service Inspection must be carried out in accordance with the instructions in the Warranty and Service Book.

EVERY 100 OPERATING HOURS OR AT LEAST ONCE A YEAR

- Engine oil. Replace page 27
- Oil filter. Replace page 27

EVERY 200 OPERATING HOURS OR AT LEAST ONCE A YEAR

- Fuel filter. Replace page 34
- Fuel pre-filter. Replace page 35
- Idling speed. Check page 26
- Coolant¹⁾. Replace page 30
- Seawater pump. Check impeller page 31
- Vacuum valve. Cleaning page 33
- Reverse gear. Oil change page 45
- Reverse gear. Lubricate propeller shaft seal page 48
- S-drive. Oil change page 45
- S-drive. Check rubber seal (hull/drive) page 48
- S-drive/Reverse gear. Checking corrosion protection page 46

¹⁾ If the freshwater system is filled with an anti-corrosion agent mixture it must be changed every year.
If the freshwater system is filled with an antifreeze (glycol) mixture it must be changed every other year.

EVERY 400 OPERATING HOURS OR AT LEAST ONCE EVERY TWO YEARS

- Air Cleaner (ACL). Check page 25
- Coolant¹⁾. Replace page 30
- Heat exchanger. Cleaning page 30
- Injectors. Test pressure not shown
- Valve clearance. Adjustment not shown

¹⁾ If the freshwater system is filled with an anti-corrosion agent mixture it must be changed every year.
If the freshwater system is filled with an antifreeze (glycol) mixture it must be changed every other year.

EVERY FOURTH YEAR

- Folding propeller. Replace tab washer and locking screw page 46

EVERY 500 OPERATING HOURS OR AT LEAST EVERY FIFTH YEAR

- Reverse gear. Replacing propeller shaft seal not shown

EVERY SEVENTH YEAR

- S-drive. Replacing rubber seal between drive and hull not shown

Maintenance

This chapter contains instructions regarding how the above maintenance points should be carried out together with general technical information. Read the instructions carefully before starting work. Maintenance intervals are contained in the chapter above. Maintenance schedule

⚠ WARNING! Read the safety precautions for maintenance and service in the chapter: Safety Precautions, before starting work.

⚠ WARNING! Unless otherwise specified all maintenance and service must be carried out with the engine stopped. Stop the engine before opening or removing engine hatches. Immobilize the engine by removing the ignition key, turning off the power supply with the main switch.

Engine, general

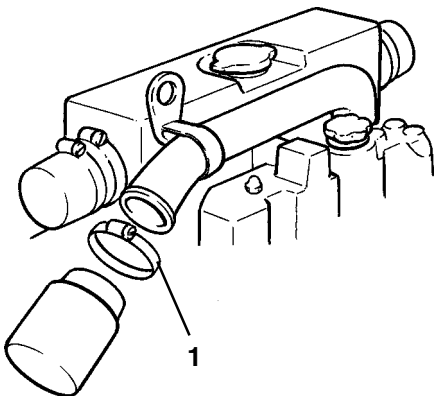

Air Cleaner (ACL). Cleaning

Clean the filter when necessary by cleaning it with a soap solution. Rinse afterwards in clean water. Squeeze out the filter and allow to dry.

MD2020, MD2030, MD2040: Remove the hose clamp (1) and remove the filter. Remove the spring inside the filter. Clean the filter.

⚠ IMPORTANT! Take care that no contaminants enter the engine.

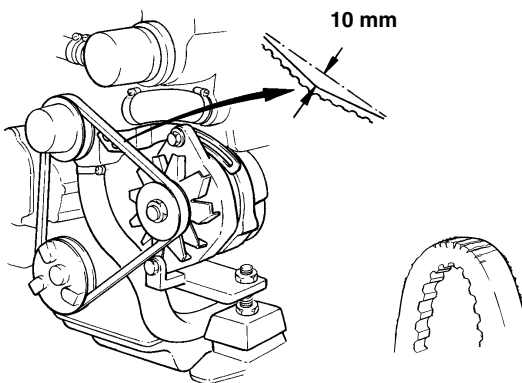

Drive belt. Check

The belt drives both the circulation pump and the generator. A belt that is too loose can result in slippage, poor cooling and poor charging. A belt that is too tight can damage the bearings in the circulation pump and damage the generator.

Check the tension of the belt regularly. Adjust as required. Check that the belt is not cracked or damaged. Replace a worn belt. Keep a spare belt on-board.

Adjustment and replacement: See next page.

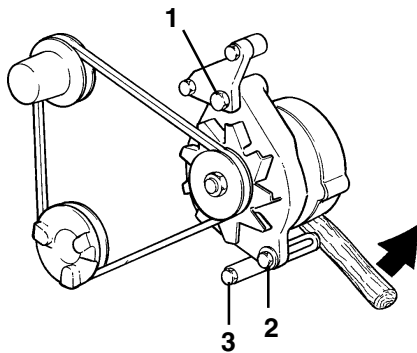

MD2010, MD2020

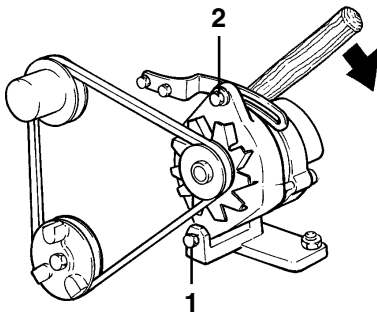

MD2030, MD2040

Drive belt. Adjusting and replacing

⚠ WARNING! Always turn the engine off before starting maintenance work.

⚠ IMPORTANT! Tighten screw (1) to 50-60 Nm.

Check and adjust as necessary after operating the engine when the belts are warm.

It should be possible to depress a belt at the correct tension approx. 10 mm between the pulleys using normal thumb pressure. To adjust slacken off the screws (1 and 2) and if necessary also screw (3) on 2010, 2020. Tension the belt, adjust to the correct tension and tighten the screws. Check the tension.

To replace the belt slacken off screws (1 and 2) and if necessary screw (3) on the 2010 and 2020. Press the generator in towards the cylinder block so that the belt can be removed. Clean off the pulley grooves. Install the new belt. Adjust as above. Check belt tension again after a few hours' operation.

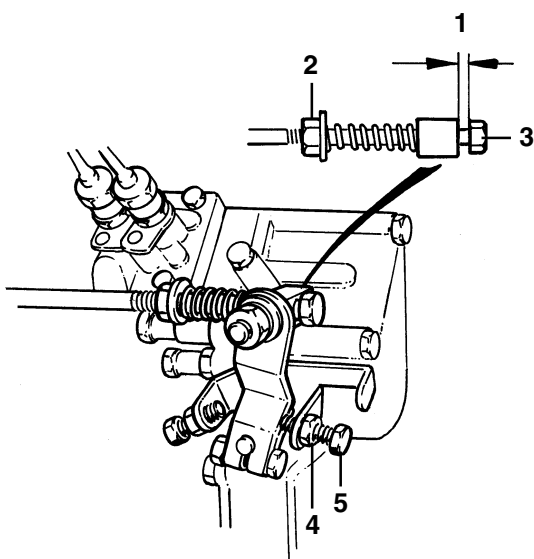

Idling. Adjustment

The idling speed should be 850 ± 25 rpm. A lower engine speed can cause the engine to stall and a higher engine speeds can cause extra stresses to the drive/reverse when shifting.

Adjust with the engine at operating temperature as follows:

1* Set the control lever in the neutral position. Check that gap (1) is approx. 3 mm. Adjustment: Slacken off the locknut (2) and adjust until the correct gap is obtained with screw (3). Tighten the locknut.

*This point does not apply to boats with double control positions.

2 Start engine and allow to idle with gear selector in neutral.

⚠ WARNING! Approaching or working on a running engine is dangerous. Watch out for rotating components and hot surfaces.

3 Slacken off locknut (4). Adjust engine speed with adjustment screw (5). Tighten the locknut. Repeat step 1.

Lubrication system

⚠ IMPORTANT! With a new or reconditioned engine, the oil and oil filters must be changed after 20-50 hours of operation. After that they should be changed every 100 operating hours or at least once a year. Use only the recommended grades of oil: See the chapter "Technical Data".

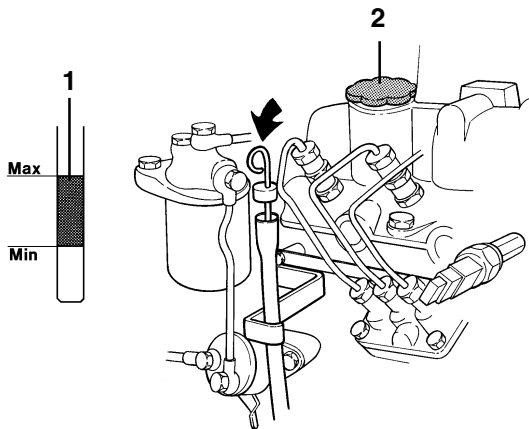

Oil level. Checking and topping up

The oil level should be within the marked area on the dipstick (1). It should be checked every day before the engine is started. Topping up is done through the valve cover (2). Top up oil slowly. Wait a few minutes before checking the oil level again to give the oil time to run down to the oil pan. Then check the level again. Use only the recommended grades of oil: See the chapter "Technical Data".

⚠ IMPORTANT! Do not fill the oil above the MAX level.

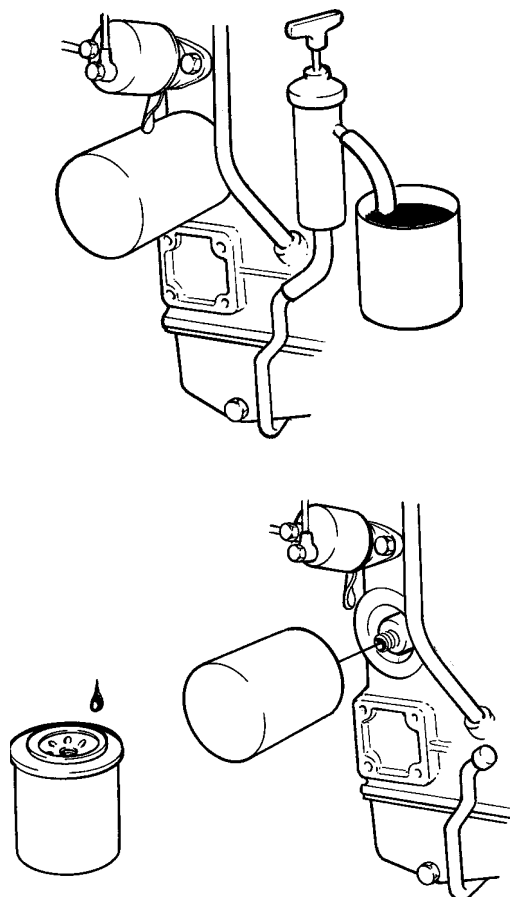

Oil and oil filters. Changing

1. Run the engine to operating temperature so that the oil is easier to suck out. Stop the engine.
2. Suck out the oil using an oil drain pump through oil drain pipe (1).
⚠ WARNING! Hot oil and hot surfaces can cause burns.
3. Unscrew the old filter. (To avoid oil spills put a plastic bag over the filter before it is unscrewed).
4. Check that the engine mating surface is clean.
5. Moisten the filter rubber gasket with a little oil. Screw on the new filter by hand until it is in contact with the mating surface. And then a further half turn **but no more!**
6. Top up oil to correct level. Start the engine and let it idle. Check that the warning lamp for low oil pressure goes out.
7. Stop the engine. Wait for approx. 10 minutes before checking the oil level. Top up if required. Check that there are no leaks round the oil filter.

NOTE! Collect up the old oil and filter for deposit at a proper disposal site.

Cooling system

The cooling system is divided into a **freshwater** and a **seawater** system. The seawater pump sucks water into the seawater system through the drive/reverse gear. Seawater is then pumped through the heat exchanger and into the exhaust elbow pipe where it is mixed with the exhaust gases.

The freshwater system is the internal engine coolant system. It is a closed system driven by the circulation pump. The freshwater system engine coolant is cooled in the heat exchanger by the seawater.

⚠ WARNING! Risk for water penetration when working with the cooling system. Close the sea cock.

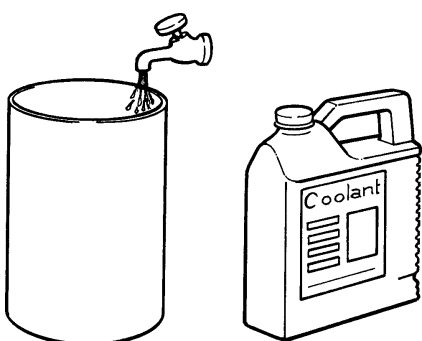

Coolant. General

The freshwater system must be filled with a coolant that protects the engine against internal corrosion and from freezing, if the climate requires it.

⚠ IMPORTANT! Never use water alone.

If the freshwater system is filled with antifreeze mixture it must be changed every other year. If the system is filled with anti-corrosion agent mixture it must be changed every year.

Water quality

To avoid the risk of blocking the cooling system the coolant should be mixed with **clean** water. If there is any doubt over the water quality **distilled water** or **premixed coolant** should be used.

In event of risk of freezing

Use a mixture of 50% Volvo Penta antifreeze (glycol) and 50% pure water. This mixture will protect against freezing to a temperature of approx. -40°C (-40°F) and should be used all year round.

Mix the coolant in a separate container before filling.

⚠ IMPORTANT! There should be at least 40% antifreeze in the system for complete protection against corrosion.

⚠ WARNING! Glycol is harmful to health (dangerous if ingested).



In there is no of risk of freezing

When there is **never** a risk of freezing water **may** be used as coolant with addition of Volvo Penta anti corrosion agent.

Mix according to the instructions on the packaging. Warm up the engine after filling to allow the additive to work as efficiently as possible.

If operating hours exceed 600 hours per annum the coolant anti corrosion must be complemented with ½ liter anti corrosion agent every 600 hours.

⚠ WARNING! Anti-corrosive agents are harmful to health (dangerous if ingested).

⚠ IMPORTANT! Never mix antifreeze (glycol) and anti-corrosive agents. The two combined can produce foam and drastically reduce the coolant's effectiveness.

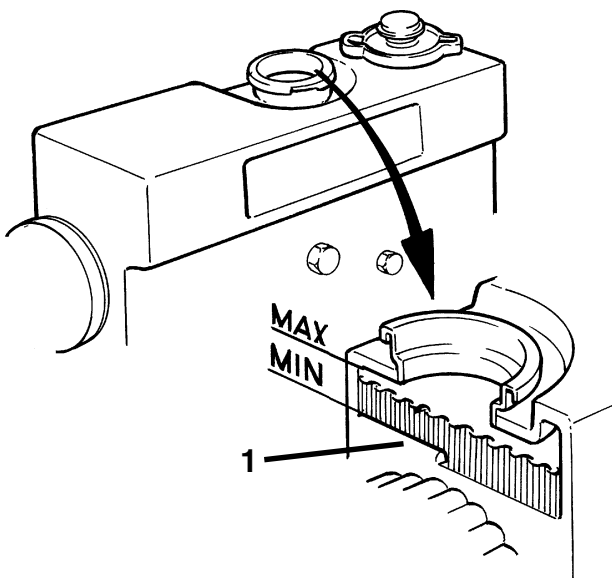

Coolant level. Checking and topping up

⚠ WARNING! Do not open the engine coolant system filler cap when the engine is still hot except in an emergency. Steam or hot coolant may spray out.

Turn the filler cap to the first stop and let any pressure escape from the system before removing the cap. Top up coolant if necessary. The level should lie between the filler neck lower edge and the level spur (1). Reinstall the filler cap.

If a separate expansion tank is installed (optional extra) the level should be between the MAX and MIN marks.

⚠ IMPORTANT! When filling a completely drained system the coolant level must be checked after an hours use because the system is self bleeding. Top up if required.

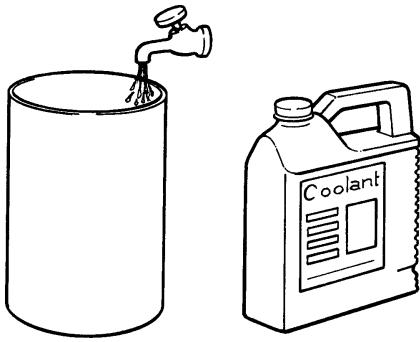

Coolant. Changing

The corrosion-proofing additives become less effective with time and the coolant must be changed. If the freshwater system is filled with antifreeze mixture it must be changed every other year. If the system is filled with anti-corrosion agent mixture it must be changed every year.

Drain the coolant and clean the heat exchanger as follows. Close the drain cock and fill with fresh coolant.

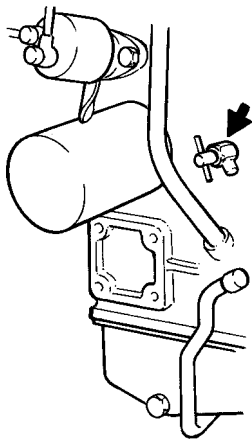

Coolant. Draining

Position a container on the starboard side of the cylinder block. Remove the filler cap on the heat exchanger (this lets the coolant run out faster). Open the drain cock or remove the plug and drain all the coolant. Before filling with coolant clean the heat exchanger as follows.

NOTE! Deposit old coolant at a properly designated disposal site.

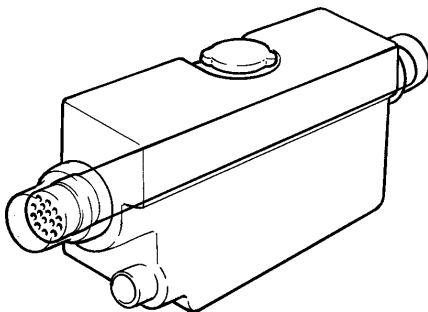

Heat exchanger. Cleaning

Cooling performance is reduced by scaling in the heat exchanger. It should therefore be flushed when the coolant is changed.

1. Drain the coolant as above.
2. Insert a hose into the filler pipe on the heat exchanger. Flush the fresh water until the water which runs out of the drain cocks is clean. Allow all the water to run out.
3. Close the drain cock. Fill with new coolant to correct level. Reinstall the filler cap.

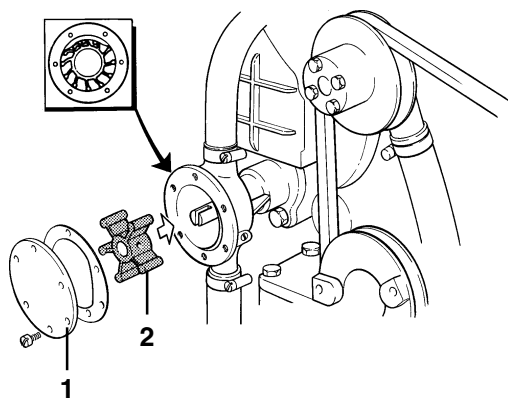
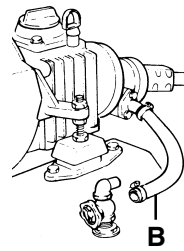
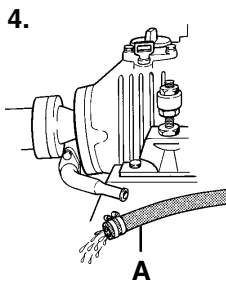
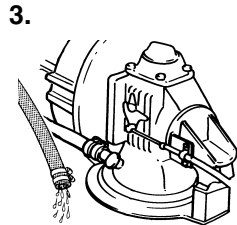
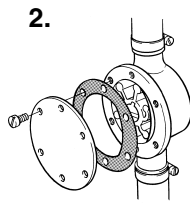
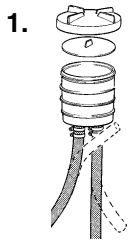

Seawater system. Draining

To prevent freezing damage the seawater system must be drained in cold weather where there is a risk of frost.

⚠ WARNING! Risk for water penetration. Close the sea cock if the boat is in the water. If the boat is laid up then the sea cock can be open.

1. Drain seawater filter (accessory). Remove the cover and sealing plate on the sea water filter. Disconnect hoses and drain them.
2. Remove the cover from the seawater pump and let the water run out.
3. **Engine with drive:** Disconnect seawater pump hose by the drive and bend down so that the water runs out.
4. **Engine with reverse gear** Disconnect seawater pump hose (A) by the drive and bend down so that the water runs out. Disconnect hose (B) by the sea cock and empty it of water.
5. Connect and tighten all hoses. Reinstall the cover on the seawater pump* and the cover and seal on the seawater filter.

* When laying up the boat, remove the impeller from the seawater pump and store it in a cool place in a plastic bag. Reinstall the impeller when bringing the boat out of storage.

Impeller. Checking/Replacing

⚠ WARNING! Risk for water penetration. Close the sea cock.

Close the sea cock. Remove cover (1) on the seawater pump. Remove impeller (2). If there are cracks or other defects the impeller must be replaced. Lubricate the pump housing and the inside of the cover with a little waterproof grease **for rubber**. Reinstall the impeller using a clockwise rotating movement. Install the cover together with a new gasket. Open the sea cock.

⚠ IMPORTANT! Always carry a spare impeller on board.

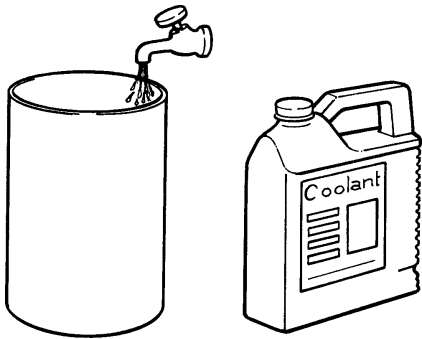
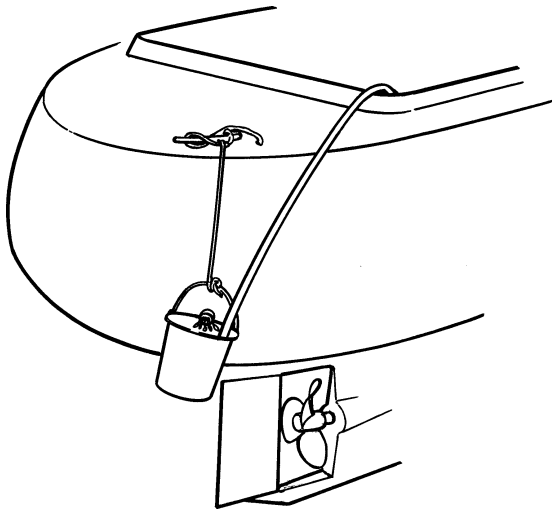

Seawater system. Cleaning and inhibiting

To prevent the build up of deposits and salt crystals in the seawater system it must be flushed with freshwater. When the boat is laid up it must also be inhibited.

⚠ WARNING! There is a risk of water penetration. Cleaning and inhibiting the seawater system should be carried out with the boat on land.

1. Open the sea cock.
2. Secure a container by the exhaust outlet.
3. Disconnect seawater hose (from the sea cock) on the reverse gear or on the seawater pump if the engine has an S-drive.
4. Connect a hose* which is long enough to reach the container so that the freshwater can be circulated.

* Internal diameter = 19 mm.

5. Fill the container with freshwater. Check that there is nothing that will get splashed behind the exhaust outlet.

⚠ IMPORTANT! The impeller will be damaged if it runs dry.

6. Set the gear control lever in the neutral position. Check that nobody is near the propellers. Start the engine. Let it run at fast idle a few minutes. Stop the engine.

⚠ WARNING! Approaching or working on a running engine is dangerous. Watch out for rotating components and hot surfaces.

7. To inhibit the seawater system repeat points 5 and 6 but replace the freshwater with antifreeze (50% glycol and 50% fresh water).
8. Reconnect the seawater hose
9. The system is now inhibited. The antifreeze mixture should be left in the system while the boat is laid up. Drain the mixture just before the boat is launched. Reuse the antifreeze mixture next season or deposit it at a properly designated disposal site.

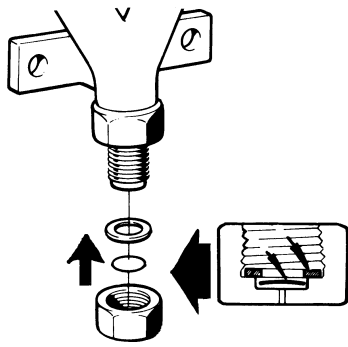

Vacuum valve. Cleaning

Some engines have a vacuum valve installed in the seawater piping.

⚠ WARNING! Risk for water penetration. Close the sea cock.

Close the sea cock. Disassemble the valve. Unscrew the hexagonal cover. In the cover there is a membrane and a gasket. Clean all the parts. Turn the cover upside down. Install the membrane first and then the gasket. Turn the valve housing upside down as well. Screw the cover into position, but not too hard (0.2 kpm), or the valve may stop working.

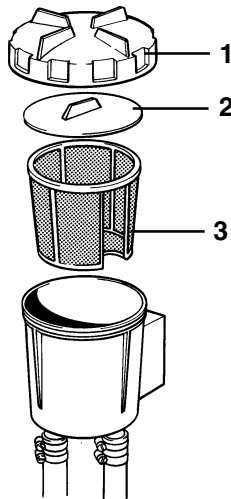

Seawater filter. Cleaning

The seawater filter is an accessory. Screw off cover (1) and remove seal plate (2). Lift out and clean the insert (3).

⚠ IMPORTANT! If the boat is used in water that has a lot of contaminants, seaweed etc. the filter must be checked more frequently than indicated in the maintenance schedule. Otherwise there is a risk the filter will clog and the engine will overheat.

Fuel system

All work on the engine injection pump or injectors must be carried out at an authorized workshop. Use only the recommended grade of fuel: See the chapter "Technical Data".

⚠ WARNING! Fire risk. When carrying out work on the fuel system make sure the engine is cold. A fuel spill onto a hot surface or an electrical component can cause a fire. Store fuel soaked rags and other flammable material in fireproof conditions.

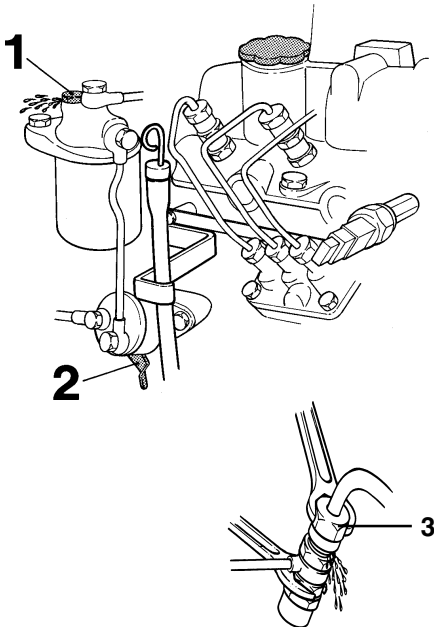

Venting the fuel system

The fuel system must be vented after fuel filters have been replaced or after refilling the fuel tank after it has been run dry.

1. Open vent screw (1) on the filter mounting approx. three turns. Avoid fuel spillage. Use rags around the venting point.
2. Pump the fuel using hand pump (2) until there are no more air bubbles visible in the fuel. Continue pumping and at the same time tighten the venting screw. If the pump effect is poor, turn the engine over slightly so that the pump drive cam changes position.
3. Slacken off the injector delivery line nuts and set the engine speed control to wide open throttle (WOT). Turn the engine over at WOT with the starter motor until fuel comes out of the delivery lines. Avoid fuel spillage. Tighten delivery line nuts.
4. Start the engine and check for leaks.

⚠ WARNING! Approaching or working on a running engine is dangerous. Watch out for rotating components and hot surfaces.

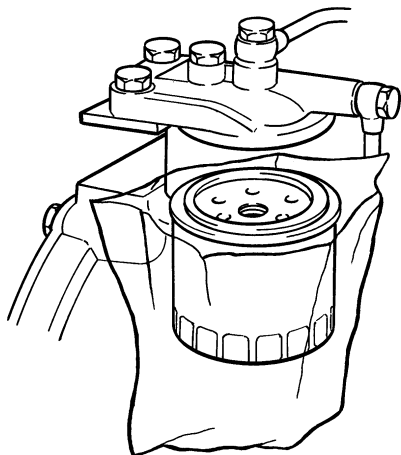

Fuel filter. Changing

Clean the filter mounting. To avoid fuel spills put a plastic bag over the filter before it is unscrewed. Unscrew the filter. Moisten the filter rubber gasket with a little oil. Screw on the new filter by hand until it is in contact with the mating surface. And then a further half turn **but no more!** Vent fuel system. **Deposit the old filter at a properly designated disposal site.**

Start the engine and check for leaks.

⚠ WARNING! Approaching or working on a running engine is dangerous. Watch out for rotating components and hot surfaces.

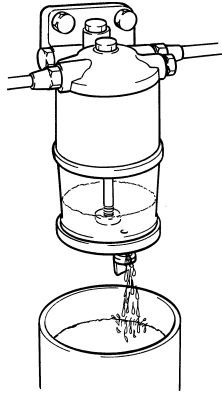

Fuel pre-filter. Draining

The fuel pre-filter is an optional extra.

Position a container under the fuel filter. Drain off water and contaminants using the cock/plug at the bottom of the glass.

⚠ IMPORTANT! Wait a few hours after the engine has been turned off before draining the filter.

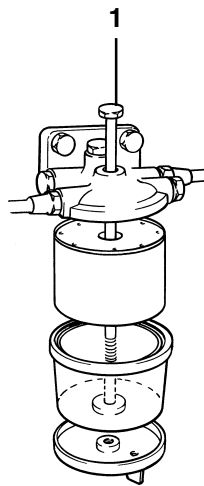

Fuel pre-filter. Replacing filter insert

Close fuel cock at the fuel tank. Position a container under the fuel filter.

Remove the glass bowl by slackening off screw (1). Empty and clean glass. Replace insert and reinstall glass. Open fuel cock. Vent fuel system. **Deposit the old filter insert at a properly designated disposal site.**

Start the engine and check for leaks.

⚠ WARNING! Approaching or working on a running engine is dangerous. Watch out for rotating components and hot surfaces.

Electrical system

⚠ WARNING! Always stop the engine and break the current using the main switches before working on the electrical system. Isolate shore current to the engine block heater, battery charger, or accessories mounted on the engine.

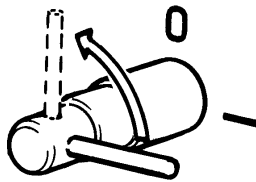

Main switch

The main switch must never be turned off before the engine has stopped. If the circuit between the generator and the battery is cut off when the engine is running the generator can be seriously damaged. For the same reason charging circuits must never be switched over while the engine is running.

⚠ IMPORTANT! Never break the circuit with the main switches while the engine is running.

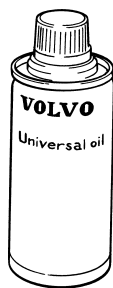

Electrical connections

Also check that all electrical connections are dry and free of oxidation and that there are no loose connections. If necessary, spray these connections with a water-repellent spray (Volvo Penta Universal oil).

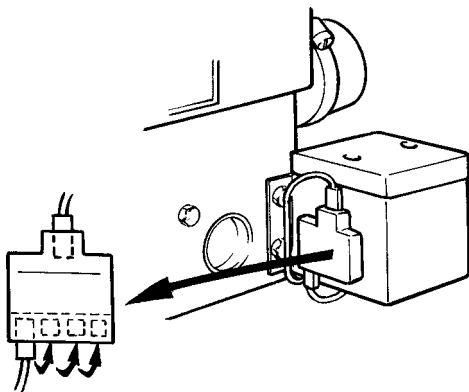

Fuses

The engine has a fuse holder with four 15 A fuses. This is located on the relay box to the left at the rear of the engine. One fuse protects the system and cuts power in the event of an overload, the others are spares.

If a fuse blows the system can be reconnected by moving the cable to the next fuse. Always investigate the cause of an overload before resetting the fuse!

⚠ IMPORTANT! Make sure that you always have spare fuses on board.



Battery. Maintenance

⚠ WARNING! Risk of fire and explosion. Never allow an open flame or electric sparks near the battery or batteries.

⚠ WARNING! Never mix up battery positive and negative terminals. This may cause sparks and an explosion.

⚠ WARNING! The battery electrolyte contains extremely corrosive sulfuric acid. Protect your skin and clothes when charging or handling batteries. Always use protective goggles and gloves. If battery electrolyte comes into contact with unprotected skin wash off immediately using plenty of water and soap. If battery acid comes into contact with the eyes, flush immediately with plenty of water and obtain medical assistance without delay.

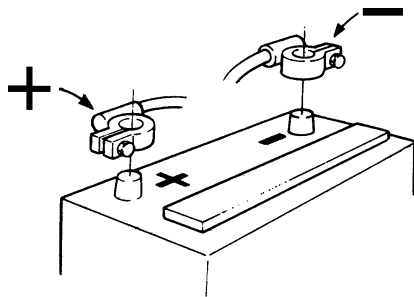

Connecting and disconnecting

First connect the red battery lead + to the battery + terminal. Then connect the black battery lead - to the battery - terminal.

When disconnecting the battery, disconnect the -lead (black) first and then the + lead (red).

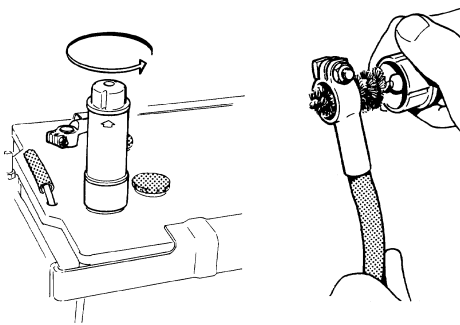

Cleaning

Keep batteries dry and clean. Oxidation or dirt on the battery and battery terminals can cause short-circuits, voltage drop and discharge especially in damp weather. Clean the battery terminals and leads to remove oxidation using a brass brush. Tighten the cable terminals well and grease them with terminal grease or petroleum jelly.

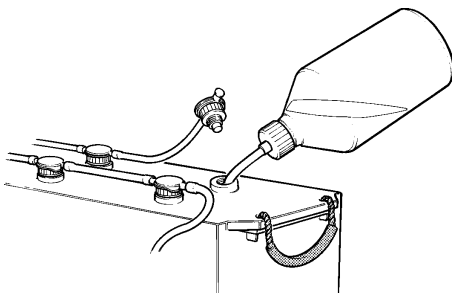

Topping up

The electrolyte should be 5 - 10 mm over the plates in the battery. Top up using **distilled water** if necessary. Charge the battery after topping up for at least 30 minutes by running the engine at fast idle. **NOTE!** Certain maintenance-free batteries have special instructions which must be followed.

Battery. Charging

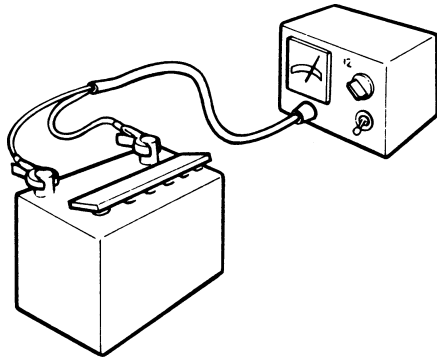

⚠ WARNING! Danger of explosion! The batteries give off hydrogen gas during charging which when mixed with air can form an explosive gas - oxyhydrogen. A short-circuit, naked flame or spark can cause a large explosion. Ensure that the ventilation is good.

⚠ WARNING! The battery electrolyte contains extremely corrosive sulfuric acid. Protect your skin and clothes when charging or handling batteries. Always use protective goggles and gloves. If battery electrolyte comes into contact with unprotected skin wash off immediately using plenty of water and soap. If battery acid comes into contact with the eyes, flush immediately with plenty of water and obtain medical assistance without delay.

If the battery has discharged it must be charged. If the boat has not been used for some time charge the battery and then trickle charge it (see manufacturer's recommendations). A poorly charged battery will be damaged and may burst in cold weather.

⚠ IMPORTANT! Follow the instructions supplied with the battery charger carefully. To avoid electrolytic corrosion when an external charger is connected, always disconnect the battery leads before connecting the charger.

When charging, unscrew filler plugs but leave them in their holes. Ventilation should be good, particularly if the batteries are being charged in an enclosed area.

⚠ WARNING! Always switch off the charging circuit **before** removing the battery charger connectors. Never mix up battery positive and negative terminals. This may cause sparks and an explosion.

Special instructions apply when **boost charging** the batteries. Avoid boost charging the batteries as it will shorten their service life.

Electrical installations

Leakage current from the electrical system can be caused by incorrect installation of electrical equipment. Leakage current can knock out the galvanic protection of components such as the drive, propeller, propeller shaft, rudder stock and keel and cause damage by electrolytic corrosion.

⚠ IMPORTANT! Work on the boat's low tension circuit should only be carried out by qualified or experienced persons. Installation or work on the shore power equipment **must only** be carried out by electricians authorized to work with high-voltage installations.

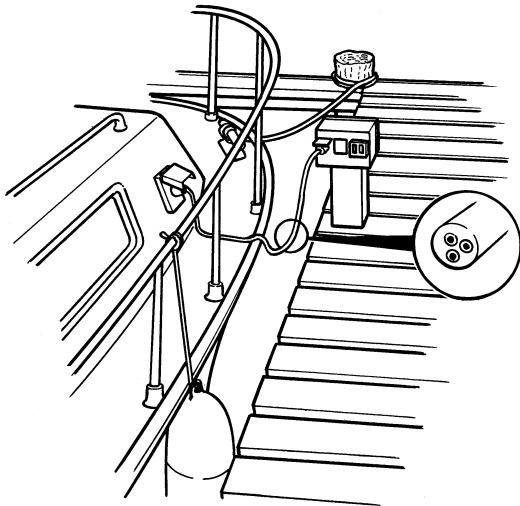

The following should always be observed:

1. If shore power is connected, the protector ground should be ashore, never in the boat. Shore power should always have a ground fault circuit breaker.

Shore power units (transformer, rectifier, battery chargers etc.) must be intended for marine usage **and the high tension circuit must be galvanically separated from the low tension circuit.**

2. Route and clamp electric cables so that they will not be exposed to rubbing, damp or bilge water in the keelson.
3. The drive/reverse gear and flywheel cover are electrically isolated (A) from the engine and must never be used as a ground.

⚠ IMPORTANT! The drive/reverse gear and flywheel cover must never be used as a ground or be electrically connected to other equipment such as the radio, navigational equipment, the rudder, bathing steps etc.

Protective grounds for the radio, navigational equipment, rudder, bathing steps or other equipment with separate ground leads must be connected to a common ground terminal (B).

4. There must be a main switch (C) connected to the starter battery positive (+) terminal. The main switch should cut off power to all power consuming equipment and should be switched off when the boat is not in use.

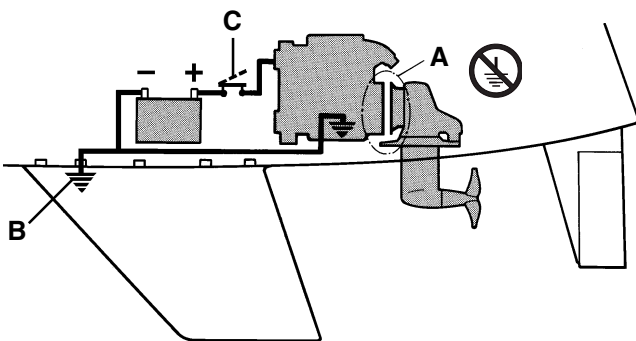

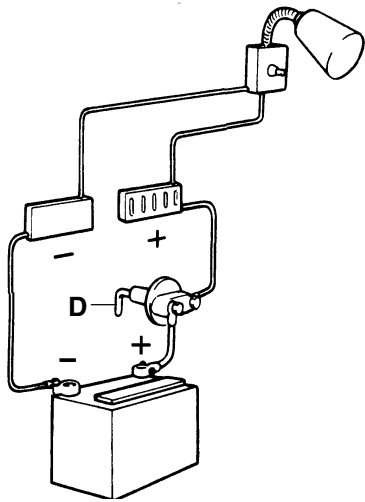

5. If an auxiliary battery is in use, a main switch (**D**) should be connected between its + terminal and the fuse block. The main switch for the auxiliary battery must cut off all power consuming equipment connected to that battery and be turned off when power is no longer needed.

All equipment connected to the auxiliary battery should have separate switches.

To simultaneously charge two independent battery circuits, fit a Volvo Penta charge distributor (accessory) to the regular generator.

Wiring Diagrams

Engine 2010, 2020, 2030, 2040

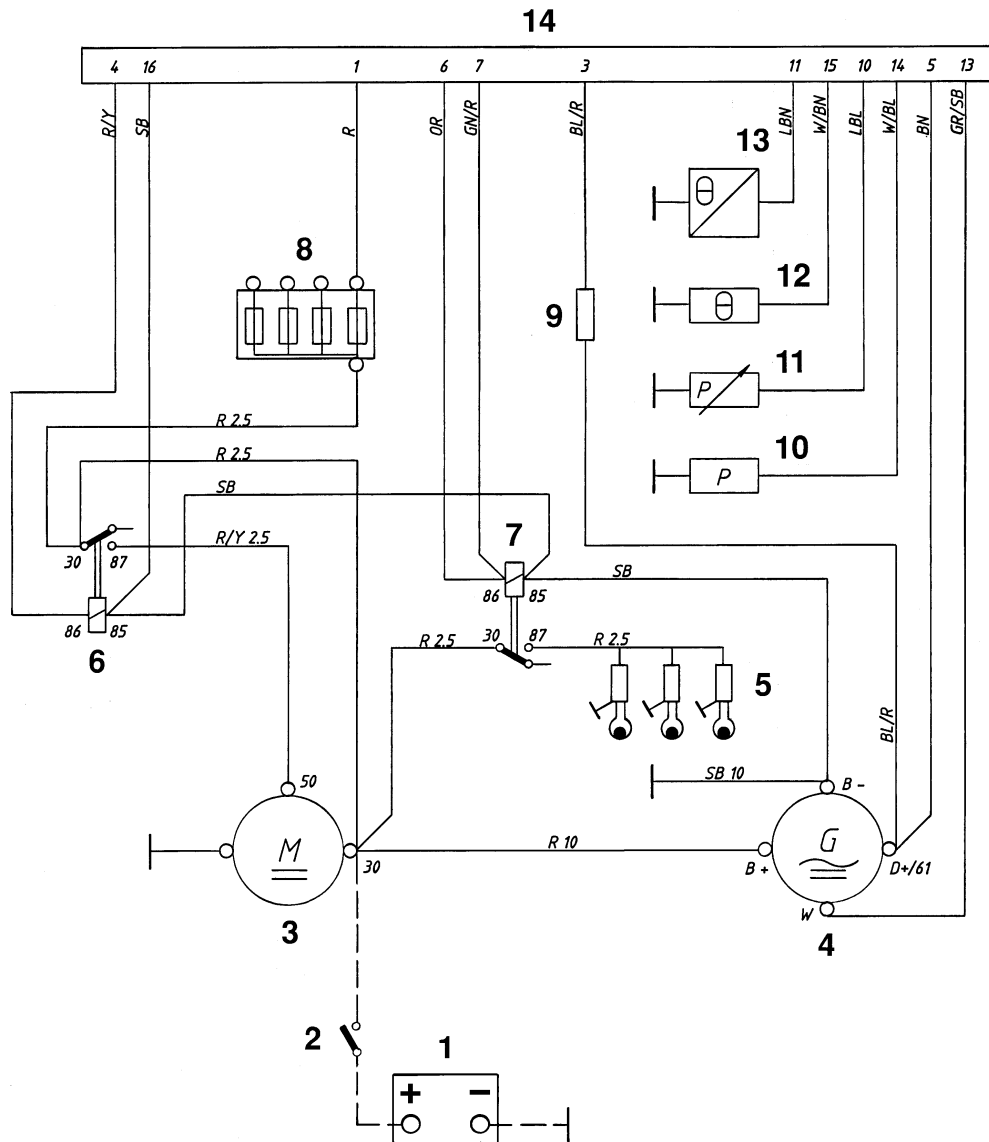

- | | | |
|---|---------------------------------|---------------------------------------|
| 1. Battery | 6. Starter relay | 11. Oil pressure gauge |
| 2. Main ON/OFF power switch | 7. Glow plug relay | 12. Coolant temperature switch |
| 3. Starter motor | 8. Fuses, max. 15A (+) | 13. Engine coolant temperature sensor |
| 4. Generator | 9. Excitation resistor | 14. Connector, 16-pin. |
| 5. Glow plugs. MD2010: 2 x. Others 3 x. | 10. Oil pressure switch, engine | |

Cable color

BL = Blue	OR = Orange
LBL = Light-blue	R = Red
BN = Brown	SB = Black
LBN = Light-brown	W = White
GN = Green	Y = Yellow
GR = Gray	

Cable areas in mm² are indicated after the color codes in the wiring diagrams.

Areas not indicated = 1.0 mm².

A broken line indicates a non-Volvo Penta cable.

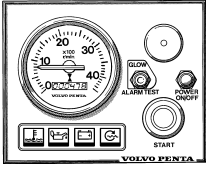

Wiring Diagrams Instrument panel without ignition switch

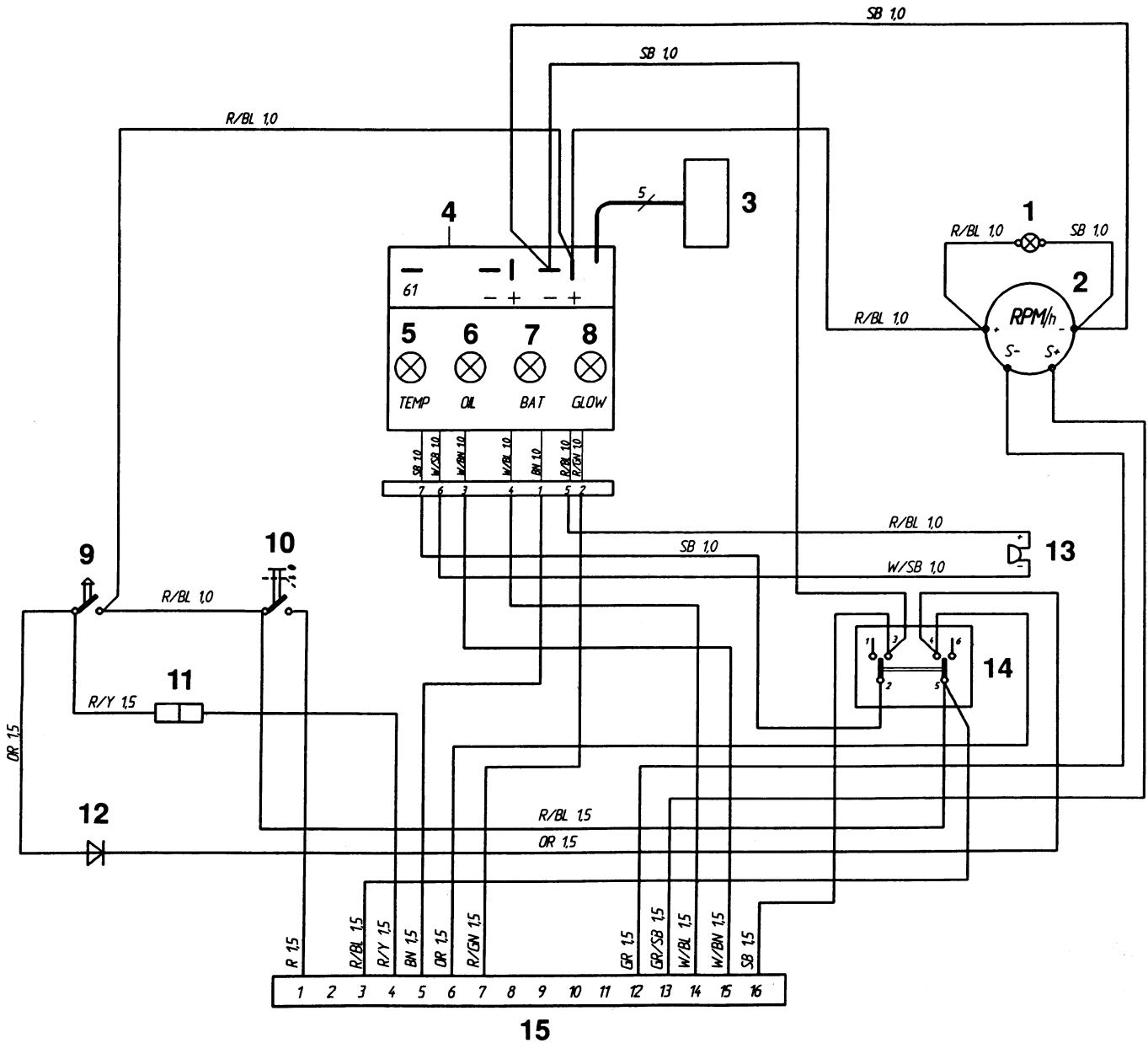

- | | |
|---|--|
| 1. Instrument lighting | 8. Glow plug indicator lamp |
| 2. Tachometer with built-in hours run meter (accessory)
Dummy plug | 9. Starter button |
| 3. Connector for connecting extra warning display (accessory) | 10. Button. Instrument panel Off/On |
| 4. Electronics module (alarm) | 11. Connector for neutral position switch, if fitted (accessory) |
| 5. Warning lamp, engine coolant temperature | 12. Semiconductor diode |
| 6. Oil pressure warning lamp | 13. Alarm |
| 7. Charge warning lamp | 14. Rocker switch. Glow plug – Alarm test/acknowledge |
| | 15. 16-pin connector |

Cable color

- | | | |
|----|---|--------|
| BL | = | Blue |
| BN | = | Brown |
| GN | = | Green |
| GR | = | Gray |
| OR | = | Orange |
| PU | = | Purple |
| R | = | Red |
| SB | = | Black |
| W | = | White |
| Y | = | Yellow |

Cable areas in mm² are indicated after the color codes in the wiring diagrams.

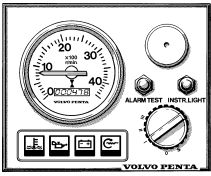

Wiring Diagrams Instrument panel with ignition switch (Alt. 1)

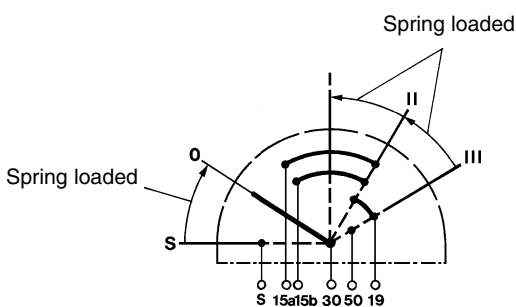
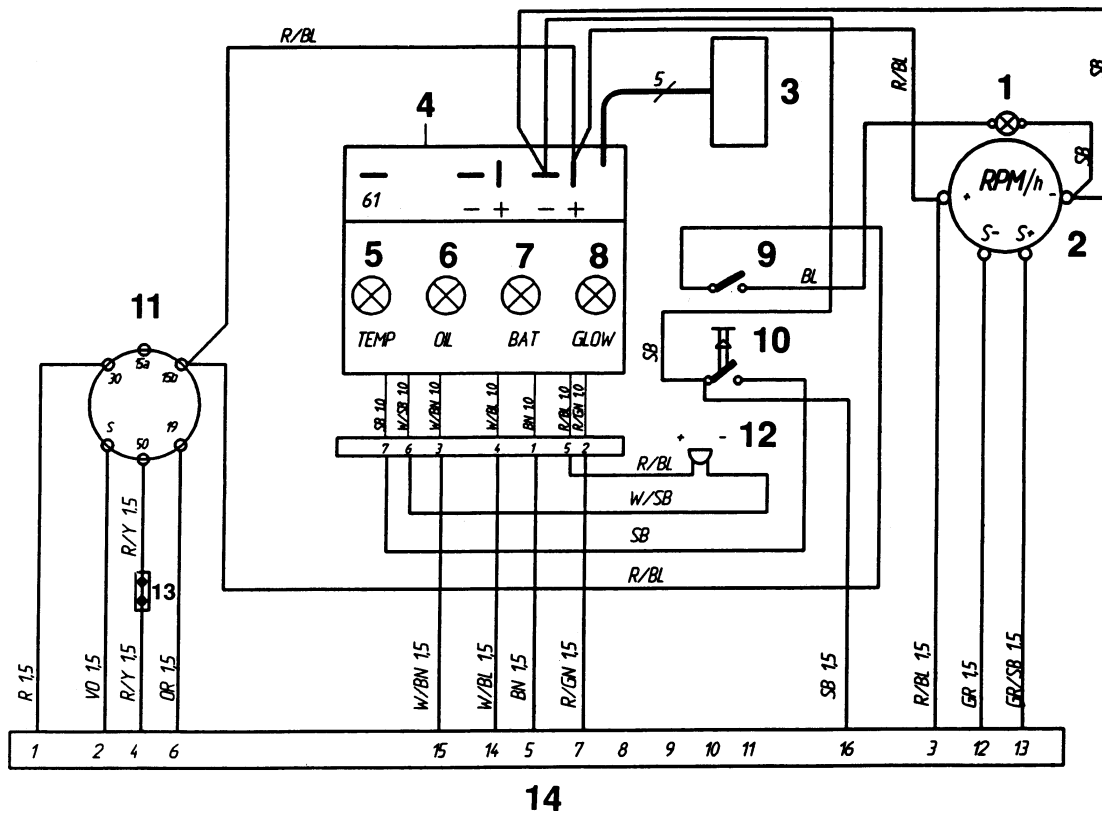

1. Instrument lighting
2. Tachometer with built-in hours run meter (accessory)
3. Connector for connecting extra warning display (accessory) Dummy plug
4. Electronics module (alarm)
5. Warning lamp, engine coolant temperature
6. Oil pressure warning lamp
7. Charge warning lamp
8. Glow plug indicator lamp
9. Switch, instrument panel lighting
10. Alarm test/acknowledgment switch
11. Ignition switch
12. Alarm
13. Connector for neutral position switch, if fitted (accessory)
14. 16-pin connector

Cable color

BL = Blue
 BN = Brown
 GN = Green
 GR = Gray
 OR = Orange
 R = Red
 SB = Black
 VO = Violet
 W = White
 Y = Yellow

Cable areas in mm² are indicated after the color codes in the wiring diagrams.

Areas not indicated = 1.0 mm².

Conversions mm²/AWG*

* American Wiring Gauge

mm ²	1.0	1.5	2.5	10	16
AWG	16 (17)	15 (16)	13	7	5

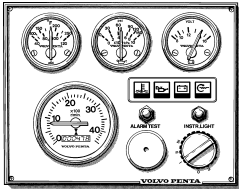

Wiring Diagrams Instrument panel with ignition switch (Alt. 2)

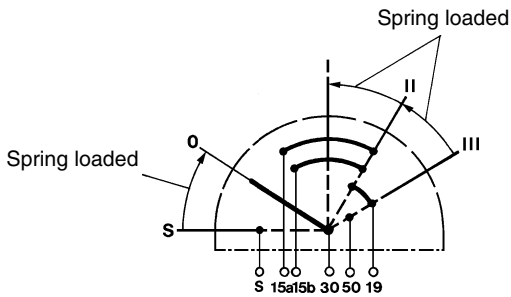
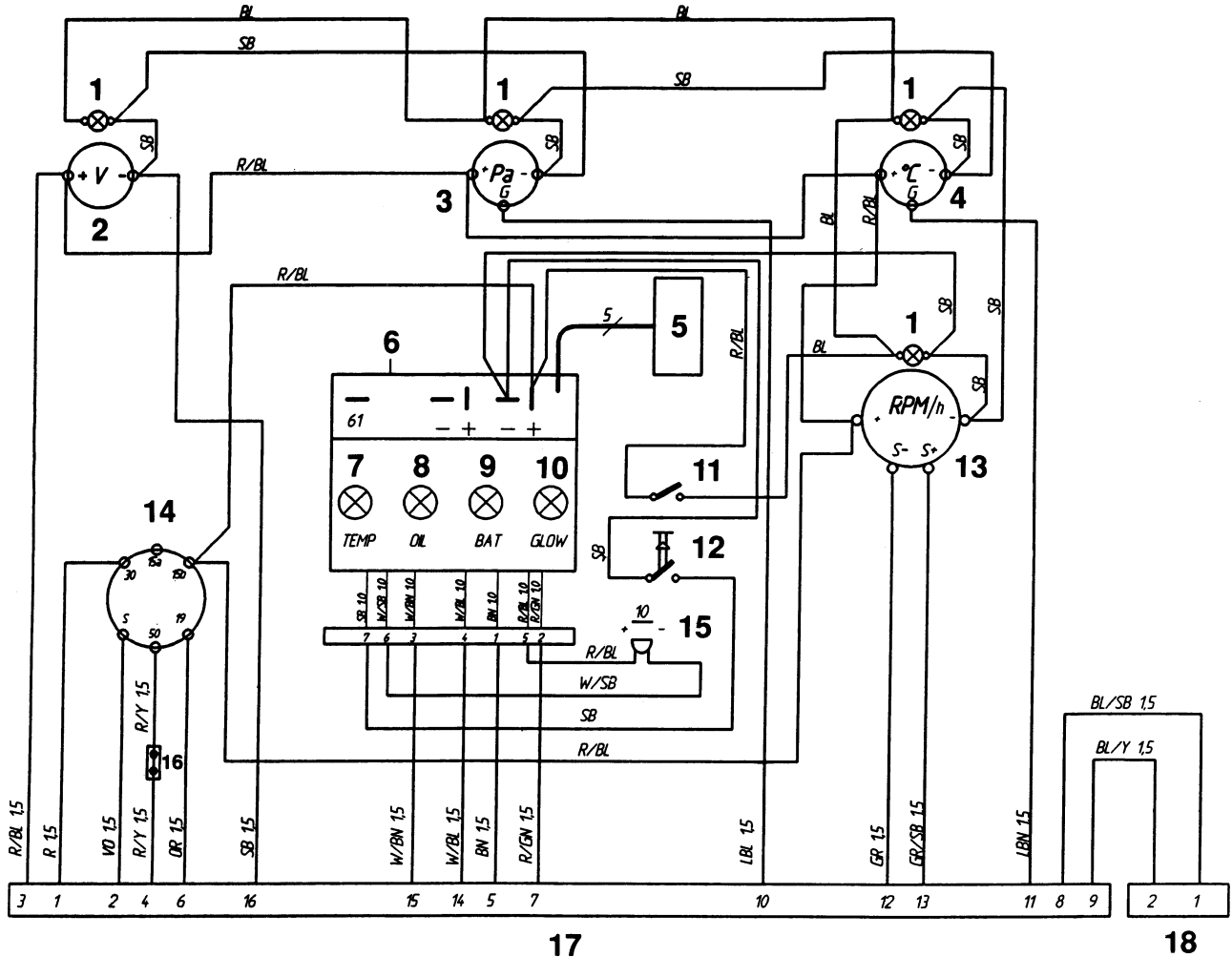

Cable color

BL = Blue	OR = Orange
LBL = Light-blue	R = Red
BN = Brown	SB = Black
LBN = Light-brown	VO = Violet
GN = Green	W = White
GR = Gray	Y = Yellow

Cable areas in mm² are indicated after the color codes in the wiring diagrams.

Areas not indicated = 1.0 mm².

1. Instrument lighting
2. Voltmeter
3. Oil pressure gauge
4. Engine coolant temperature gauge
5. Connector for extra warning display (accessory)
6. Electronics module (alarm)
7. Engine coolant temperature warning lamp
8. Oil pressure warning lamp
9. Charge warning lamp
10. Glow plug indicator lamp
11. Switch, instrument panel lighting
12. Alarm test/acknowledgment switch
13. Tachometer with built-in hours run meter (accessory). Dummy plug
14. Ignition switch
15. Alarm
16. Connector for connecting neutral position switch, if fitted (accessory)
17. 16-pin connector
18. 2-pin connector (for additional control panel)

S drive and reverse gear

The S drive and in certain cases the propeller (reverse gear) is equipped with a sacrificial anode which prevents galvanic corrosion. Faulty electrical installation can also cause the break down of the galvanic protection. Damage due to electrolytic corrosion occurs rapidly and is often extensive. For further information see the chapter: "Electrical system"

⚠ IMPORTANT! Improperly applied paint or the wrong type of paint on the keel can put the corrosion protection system out of action. For further information on painting see the chapter: Laying up/Launching

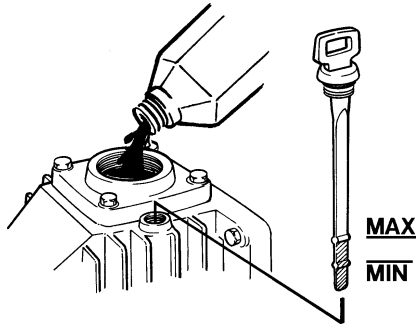

Oil level. Checking and topping up

Unscrew (counter clockwise) and remove the dipstick. Wipe off oil. Reinsert the dipstick in the drive/reverse gear **without screwing it in**. Remove again and check that the oil level is between the MAX and MIN markings on the dipstick. Top up oil if necessary. For oil quality and capacity: See the chapter "Technical Data".

⚠ IMPORTANT! The oil level should always be within the MAX and MIN range marked on the dipstick.

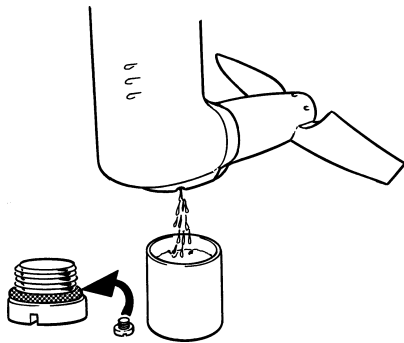

Oil change. S-drive

Remove the oil dipstick. Remove the plug on the propeller gear housing and let the oil run out. Check that the plug o-ring is intact. Replace if necessary. Install the plug and o-ring. Top up oil to correct level. For oil quality and capacity: See the chapter "Technical Data".

⚠ IMPORTANT! If oil is colored gray then water has entered the drive. Contact authorized service personnel.

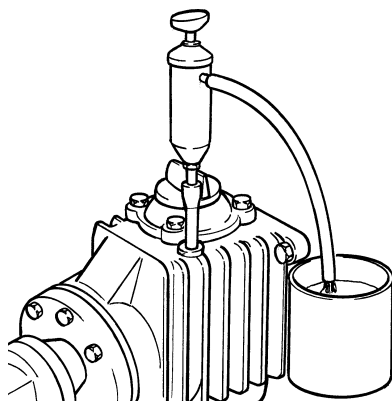

Oil change. Reverse gear

Remove the oil dipstick. Suck up oil using an oil pump through the hole for the dipstick. Top up oil to correct level. For oil quality and capacity: See the chapter "Technical Data".

Corrosion protection. Checking/Replacing

Replace the sacrificial anode when 50% of the material has been worn away or at least once a season (also applies to the sacrificial anode for the reverse gear propeller. Remedy **any paintwork damage** on the S drive according to the instruction in the chapter: Laying up/Launching.

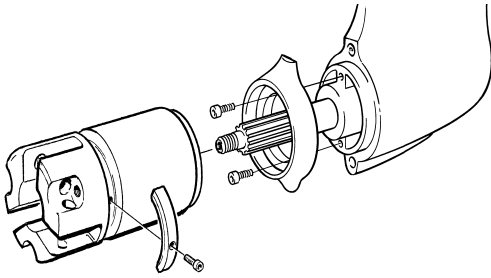

Remove the folding propeller as described below. Remove anode by removing the two screws. Scrape mating surface on the drive really clean. Install and tighten the new anode so that there is a good metal contact.

⚠ IMPORTANT! Use zinc sacrificial anodes for salt water and magnesium anodes for freshwater.

Clean the new anode to remove oxidation just before the boat is launched.

⚠ IMPORTANT! Use emery paper. Do not use a wire brush or other steel tools when cleaning, as these may damage the galvanic protection.

Folding propeller. Maintenance

The propeller should be disassembled once a year for cleaning and lubrication. Clean carefully. Apply waterproof grease to the propeller blade teeth and bearing surfaces so that the propeller can fold easily. Also apply waterproof grease to the studs (1), propeller shaft and hub.

⚠ WARNING! The line cutter (2) has very sharp edges and must be handled with care.

⚠ IMPORTANT! The tab washer (3) must be replaced every fourth year. Only a Volvo Penta original locking screw (4) may be used.

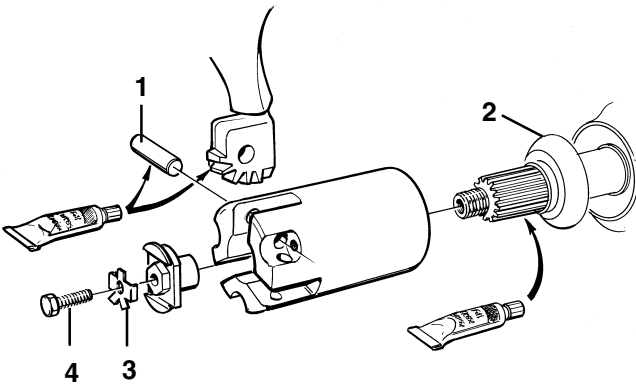

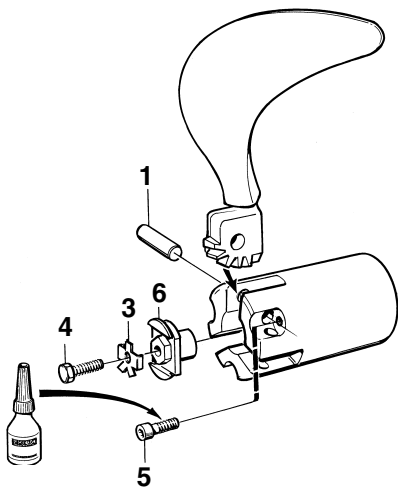

3-blade folding propeller (drive)

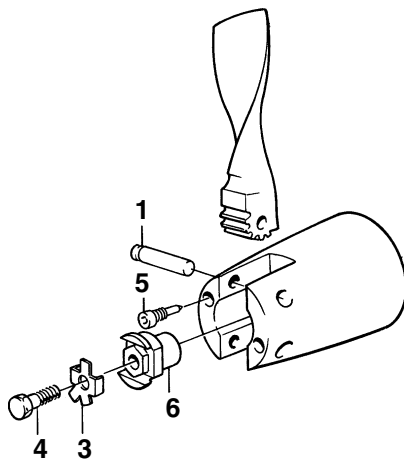

2-blade folding propeller (drive)

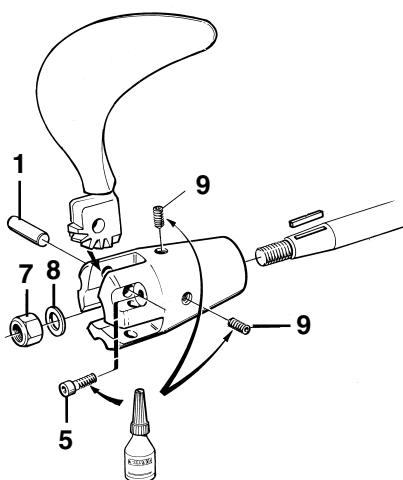

3-blade folding propeller (reverse)

Removing and installing

1. Set the control lever in the "Ahead" position.

⚠ WARNING! Immobilize the engine before starting work.

2. Remove the propeller blade by first undoing the locking screws (5) completely and then pressing out the shaft studs (1).
3. **Drive:** Bend down the tabs of the tab washer (3) and remove the locking screw (4), tab washer and nut (6).

Reverse gear: Remove the nut (7), washer (8) and then the locking screws (9).

4. Pull off the propeller hub. Clean and lubricate the propeller and propeller shaft as described.
5. Reinstall the propeller hub on the shaft.
6. **Drive:** Install the nut (6). Place a propeller blade on the hub and place a wooden block between the propeller blade and the underwater hull. Tighten locknut to 70 Nm.

Reverse gear: Install the washer (8) and tighten the nut (7) to 220 Nm. Apply **thread sealant** to the locking screws (9). After the locking screws have been tightened apply thread sealant to the screw heads as well.

7. **Drive:** Locate the tab washer (3) on the nut. Install and tighten the locking screw (4) to 20 Nm and bend one of the tab washer tabs to the screw head.
8. Install one propeller blade in the propeller hub and push in the stud (1) in such a position so the groove in the stud is exactly centered in the hole for the locking screw (5). Apply **thread sealant** to the locking screw and tighten to 20 Nm.

⚠ IMPORTANT! The locking screw (5) must be replaced every fourth year.

9. Install the other blades in the same way. Check the blades are at the same angle to the propeller shaft and that they move easily.

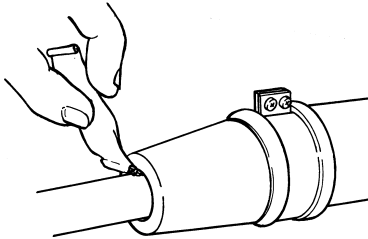
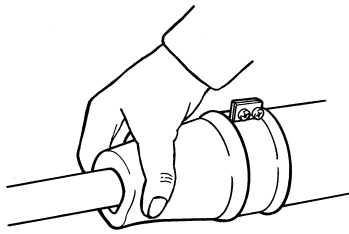

Propeller shaft seal. Reverse gear

If the boat has a Volvo Penta shaft the shaft seal must be vented and lubricated directly after launching.

Vent the bushing by pressing it together while pressing down on the shaft until water appears. Then press in approx. 1 cc **water repellent grease** into the seal.

⚠ IMPORTANT! The seal must be replaced every 500 running hours or every 5th year.

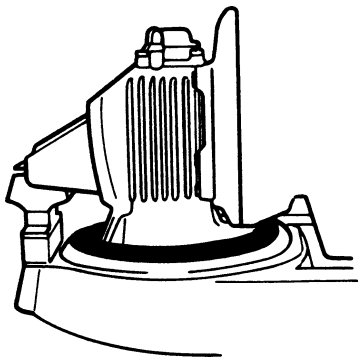

Rubber seal. S-drive

Check the rubber seal between the drive and the hull regularly for cracks and wear.

⚠ WARNING! The seal must be changed every seven years or earlier if it is defective. This work should be carried out by an authorized workshop.

Laying up and launching

Before taking the boat out of the water for winter/out-of-season storage have an authorized Volvo Penta workshop inspect the engine and other equipment.

Inhibition should be carried out to ensure that the engine and transmission are not damaged while out of commission during the winter/off-season. It is important this is done properly and that nothing is forgotten. We have therefore provided a checklist covering the most important points.

⚠ WARNING! Read the chapter on Maintenance carefully before starting work. It contains instructions on how to carry out the work safely and correctly.

Inhibiting

The following are best carried out with the boat in the water:

- Change engine oil and replace oil filter.
- Change oil in the reverse gear.
- Replace fuel filter. Replace fuel pre-filter if installed.
- Run engine to normal operating temperature.
- Take the boat out of the water:

The following should be carried out with the boat out of the water:

- Clean the hull and drive directly after taking up the boat (before it dries).

⚠ IMPORTANT! Be careful when cleaning with a high pressure water spray. Never direct the water jet at the propeller shaft seal, grommets etc.

- Change oil in the drive.
- Clean the vacuum valve and seawater filter (accessory).
- Clean and inhibit the seawater system.
- Remove the impeller from the seawater pump. Store the impeller in a sealed plastic bag in a cool place.
- Check the condition of the engine coolant anti-freeze. Top up if required.

⚠ IMPORTANT! An anti-corrosion mixture in the engine coolant system provides no protection against freezing. If there is any possibility the engine will be subjected to freezing temperatures then the system must be drained.

- Drain any water and contaminants from the fuel tank. Fill the tank completely with fuel to avoid condensation.

- Clean the outside of the engine. Do not use a high pressure spray to clean the engine. Touch up any damaged areas of paintwork with Volvo Penta original paint.
- Check all control cables and treat with rust inhibitor.
- Repair any damaged areas of paintwork with Volvo Penta original paint. NOTE! Read the special instructions on painting the drive under the heading: Painting the drive and underwater hull
- Disconnect battery leads. Clean and charge the batteries. NOTE! A poorly charged battery may burst as a result of freezing.
- Spray electrical system components with moisture repellent spray.
- Remove the propeller for storage. Grease the propeller shaft using water repellent grease. Disassemble folding propellers, clean and grease.
- Check the rubber seal between the drive and hull carefully.

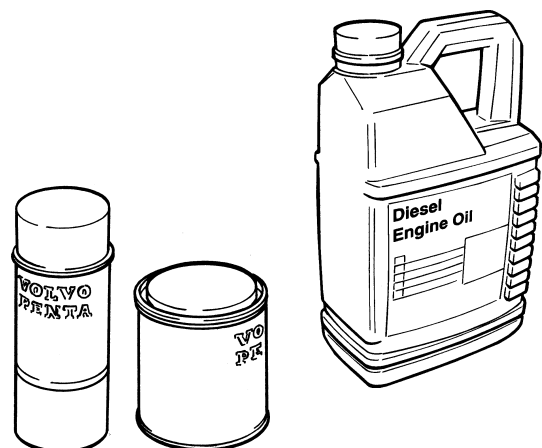

Bringing out of storage

- Check oil level in the engine and drive/reverse gear. Top up if necessary. If there is inhibiting oil in the system drain and fill with new oil, change oil filter. For correct oil grade: See the chapter "Technical Data".
 - Drain the antifreeze from the seawater system.
 - Install the impeller in the seawater pump (replace if the old one looks worn).
 - Close/tighten drain cocks/plugs.
 - Check drive belts.
 - Check the condition of rubber hoses and tighten hose clamps.
 - Check engine coolant level and antifreeze protection. Top up if necessary.
 - Connect the fully charged batteries.
 - Paint the drive and hull: See next page.
 - Check the sacrificial anode on the drive. If there is less than 50% of the anode left it must be replaced. Clean with emery cloth just before the boat is launched.
- ⚠ IMPORTANT!** Do not use a wire brush or other steel tools when cleaning, as these may damage the galvanic protection.
- Reinstall the propeller.
 - Launch the boat. Check for leaks.
 - Vent and lubricate the propeller shaft seal (reverse gear).
 - Start the engine. Check that there are no fuel, engine coolant or exhaust gas leaks and that all control functions are operating.

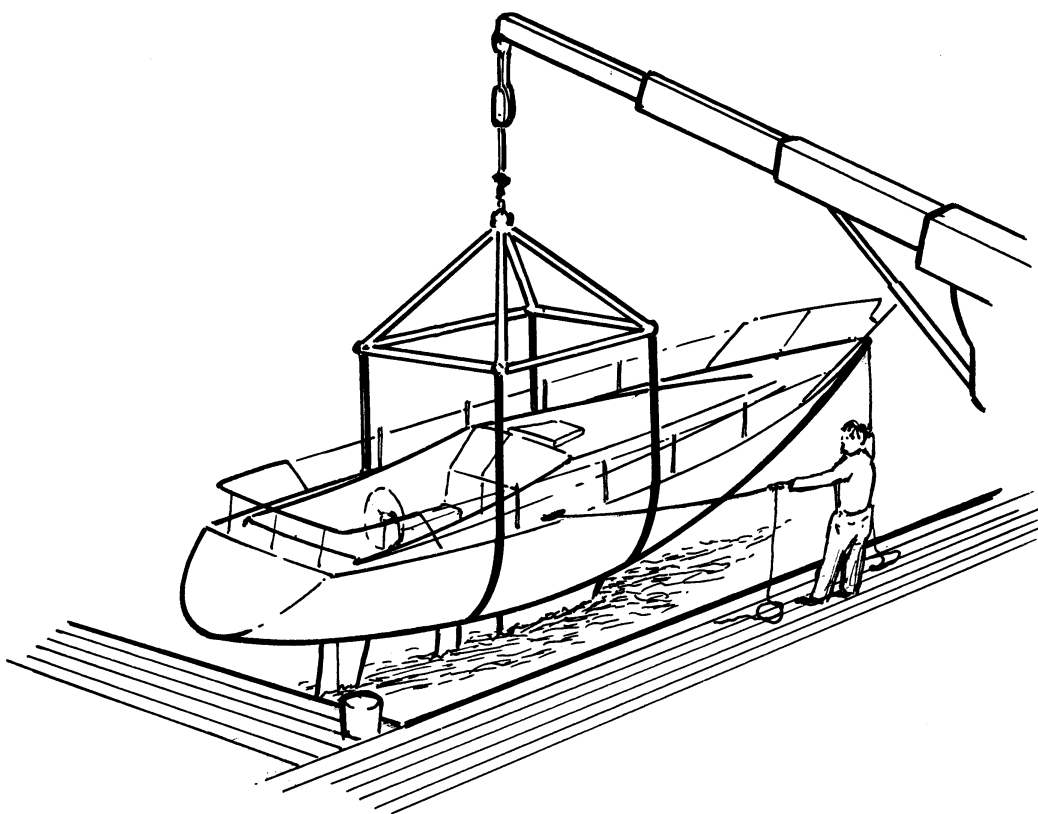

Painting the drive and underwater hull

General

Most countries have introduced legislation controlling the use of anti-fouling agents. In some cases these agents are completely forbidden for use on leisure craft. **In these cases ask your Volvo Penta dealer for advice about alternative methods.**

⚠ IMPORTANT! Find out what regulations apply to the use of anti-fouling agents.

Drive

The paintwork is part of the drive's anti-corrosion protection and it is therefore important that any paintwork damage is remedied.

Sand down metal surfaces lightly using a 120 grade paper and a finer grade for painted surfaces. Wash off using thinners or similar. Any pores in the surface should be filled and sanded down. Paint using Volvo Penta original primer and topcoat. Let the paint dry.

The drive should be painted with Volvo Penta anti-fouling to prevent fouling. Apply according to the instructions on the packaging.

⚠ IMPORTANT! The sacrificial anodes on the drive must not be painted. This also applies to stainless or bronze propellers.

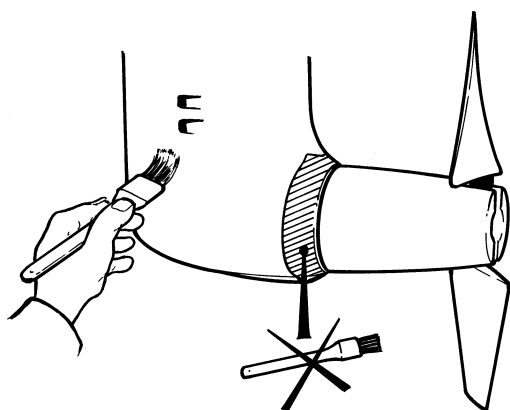

Underwater hull

Anti fouling agent containing **copper oxide can increase the risk of galvanic corrosion and therefore should never be used.**

Fault-tracing

A number of symptoms and possible reasons for engine problems are described in the table below. In case of faults or mishaps which you cannot solve, always contact the Volvo Penta dealership.

⚠ WARNING! Read the safety precautions for maintenance and service in the chapter: Safety Precautions, before starting work.

Symptoms and possible causes

Starter motor not turning or slow	1, 2, 3
Engine will not start	4, 5, 6, 7, 8, 9
Engine starts but stops again	6, 7, 8, 9
Engine difficult to start	6, 7, 8, 9
Engine does not reach correct speed at wide open throttle (WOT)	7, 8, 9, 10, 11, 12, 13, 18
Engine knocks	14
Engine runs unevenly	6, 7, 8, 9, 13, 14
Engine vibrates	18, 19
High fuel consumption	10, 11, 13, 15, 18
Black exhaust smoke	5, 13, 15, 18
Blue or white exhaust smoke	15, 25
Low oil pressure	16, 17
Engine coolant temperature too high	20, 21, 22, 23, 24
No or poor charging	2, 26

- | | | |
|-------------------------------------|--|--|
| 1. Discharged battery | 11. Fouling on underwater hull/drive/propeller | 19. Defective engine mounting |
| 2. Loose connection/open-circuit | 12. Limited speed control lever movement | 20. Too little coolant |
| 3. Fuse tripped | 13. Insufficient air supply | 21. Blocked seawater intake/pipe/filter |
| 4. Stop control pulled out | 14. Engine coolant temperature too high | 22. Circulation pump drive belt slipping |
| 5. Inadequate pre-heating | 15. Engine coolant temperature is too low | 23. Defective impeller |
| 6. Lack of fuel | 16. Lubricating oil level too low. | 24. Defective/incorrect thermostat |
| 7. Fouled fuel filter. | 17. Blocked fuel filter | 25. Lubricating oil level too high |
| 8. Air in the fuel injection system | 18. Defective/incorrect propeller | 26. Generator drive belt slipping |
| 9. Water/contaminants in the fuel | | |
| 10. Boat abnormally loaded | | |

Technical Data

General

	MD2010-C	MD2020-C	MD2030-C	MD2040-C
Engine designation	MD2010-C	MD2020-C	MD2030-C	MD2040-C
No. of cylinders	2	3	3	3
Cylinder bore	67 mm	67 mm	75 mm	84 mm
Cylinder stroke	64 mm	64 mm	72 mm	90 mm
Overall cylinder displacement	0.45 liters	0.68 liters	0.95 liters	1.50 liters
Power, see sales literature				
Idling speed	850 ±25 rpm	850 ±25 rpm	850 ±25 rpm	850 ±25 rpm
Rotation, viewed from in front	Clockwise	Clockwise	Clockwise	Clockwise
Max. permitted rake backwards while running	20°	20°	20°	20°
Max. list while running	30°	30°	30°	30°
Valve clearance (stopped, cold engine)				
inlet and outlet	0.20 mm	0.20 mm	0.20 mm	0.20 mm
Weight, dry engine	96 kg	112 kg	123 kg	170 kg

Lubrication system

Oil capacity incl. oil filter, approx.:				
no engine inclination	1.9 liters	2.8 liters	3.5 liters	5.7 liters
Oil quality according to				
Volvo Drain Specification	VDS, VDS-2	VDS, VDS-2	VDS, VDS-2	VDS, VDS-2
the API system	CD, CE, CF, CF-4, CG-4	CD, CE, CF, CF-4, CG-4	CD, CE, CF, CF-4, CG-4	CD, CE, CF, CF-4, CG-4
Viscosity at -5° - +50°C*	SAE 15W/40, SAE 20W/50	SAE 15W/40, SAE 20W/50	SAE 15W/40, SAE 20W/50	SAE 15W/40, SAE 20W/50
Oil drain plug tightening torque	30-40 Nm (3.0-4.0 kpm)	30-40 Nm (3.0-4.0 kpm)	30-40 Nm (3.0-4.0 kpm)	30-40 Nm (3.0-4.0 kpm)

* Constant ambient air temperature

Cooling system

Thermostats, no.	1 screws	1 screws	1 screws	1 screws
The thermostat starts opening at	75° ±2°C	75° ±2°C	82° ±2°C	82° ±2°C
fully open at	87°C	87°C	95°C	95°C
Freshwater system capacity, approx.	2.3 liters	2.9 liters	4.5 liters	7.5 liters

Electrical system

System voltage	12 V	12 V	12 V	12 V
Fuses	15A	15A	15A	15A
Battery capacity (starter battery)	70 Ah	70 Ah	70 Ah	70 Ah
AC generator voltage/max. current	14V/60A	14V/60A	14V/60A	14V/60A
output approx.	840 W	840 W	840 W	840 W
Starter motor, output approx.	0.7 kW	0.7 kW	1.2 kW	2.0 kW

Reverse gear

Type designation	MS2L-E, MS2A-E
Gear ratios:	
MS2L	2.3:1, 2.7:1
MS2A	2.4:1, 3.0:1
Angle (output shaft):	
MS2L	0°
MS2A	7°
Oil capacity, approx.	0.8 liters
Oil grade (in accordance with API system)	CD
Viscosity	SAE 15W/40
Weight	17 kg
Tightening torque:	
oil drain plug	20 ±5 Nm (2 ±0.5 kpm)

Sailing boat drive

Type designation	120S-E
Gear ratio	2.48:1
Oil capacity, approx.	2.8 liters
volume difference min.-max.	0.07 liters
Oil grade (in accordance with API system)	CD
Viscosity	SAE 15W/40
Weight	28 kg
Tightening torque:	
oil drain plug	10 ±5 Nm (1 ±0.5 kpm)

Fuel specification

Fuel must meet national and international standards at least. For example:

EN 590 (with national environmental and cold standards)

ASTM D 975 No 1-D and 2-D

JIS KK 2204

Sulphur content: According to statutory requirements.

Fuels with extremely low sulphur contents ("urban diesel" in Sweden and "city diesel" in Finland) can cause a drop in output of 5% and an increase in fuel consumption of 2–3%.

