

OPERATOR'S MANUAL

D2-55, D2-75

This operator's manual is also available in the following languages:

GER

Diese Betriebsanleitung ist auch auf Deutsch erhältlich.

Ein Bestellcoupon ist am Ende der Betriebsanleitung zu finden.

DUT

Dit instructieboek kan worden besteld in het Nederlands.

De bestelcoupon vindt u achter in het instructieboek.

FRE

Ce manuel d'instructions peut être commandé en français.

Vous trouverez un bon de commande à la fin du manuel d'instructions.

DAN

Denne instruktionsbog kan bestilles på dansk.

Bestillingskupon findes i slutningen af instruktionsbogen.

SPA

Este libro de instrucciones puede solicitarse en español.

El cupón de pedido se encuentra al final del libro.

FIN

Tämä ohjekirjan voi tilata myös suomenkielisenä.

Tilauskuponki on ohjekirjan lopussa.

SWE

Den här instruktionsboken kan beställas på svenska.

Beställningskupong finns i slutet av instruktionsboken.

POR

Este manual de instruções pode ser encomendado em português.

O talão de requerimento encontra-se no fim do manual.

ITA

Questo manuale d'istruzioni può essere ordinato in lingua italiana.

Il tagliando per l'ordinazione è riportato alla fine del manuale.

GRE

Αυτό το εγχειρίδιο χρήσης διατίθεται στην αγγλική γλώσσα.

Για να παραγγείλετε ένα αντίτυπο, συμπληρώστε τη φόρμα που βρίσκεται στο τέλος αυτού του εγχειριδίου χρήσης.

CALIFORNIA

Proposition 65 Warning

Diesel engine exhaust and some of its constituents are known to the State of California to cause cancer, birth defects, and other reproductive harm.



Welcome aboard

Volvo Penta marine engines are used all over the world today. They are used in all possible operating conditions for professional as well as leisure purposes. That's not surprising.

After more than 90 years as an engine manufacturer and after delivering over 500,000 marine engines, the Volvo Penta name has become a symbol of reliability, technical innovation, top of the range performance and long service life. We also believe that this is what you demand and expect of your Volvo Penta engine.

We would like you to read this operator's manual thoroughly and consider the advice we give on running and maintenance before you cast off on your maiden voyage so that you will be ensured of fulfilling your expectations.

Best regards

AB VOLVO PENTA

Contents

Safety Information	3–7	Maintenance schedule	27–28
Introduction	8–9	Maintenance and care	29–52
Running-in	8	Engine, general	29
Fuel and oil types	8	Lubrication system	32
Certified engines	9	Freshwater system	33
Warranty information	9	Seawater system	36
Introduction	10–14	Fuel system	40
D2-55	12	Electrical system	42
D2-75	12	Electrical components diagram	47
Identification numbers	14	S drive and reverse gear	48
Instrumentation	15–18	Laying up/Launching	53–55
Controls	19	Inhibiting	53
Starting the engine.	20–23	Bringing out of storage	54
Preparations and starting	20	Painting the drive and underwater hull	55
Starting the engine using auxiliary batteries	23	Fault-tracing	56
Operation	24–25	Technical Data	57–58
Checking instruments	24	General	57
Cruising speed	24	Lubrication, cooling and electrical systems	57
Maneuvering	25	S drive and reverse gear	58
When sailing	25	Fuel specification	58
Stopping the engine	26		
After stopping the engine	26		
Laying up	26		
Cold weather precautions	26		

Safety Precautions

Read this chapter carefully. It concerns your safety. This chapter describes how safety information is presented in the Operator's Manual and on the engine itself. It also gives a general account of basic safety precautions to be taken when operating the boat and maintaining the engine.

Check that you have the correct Operator's Manual before you read on. If this is not the case please contact your Volvo Penta dealer.



If operations are performed incorrectly this could result in personal injury, or damage to property or the engine. Read the Operator's Manual carefully before operating or servicing the engine. If anything is unclear please contact your Volvo Penta dealer for assistance.

 This symbol is used in the book and on the engine to make you aware of safety information. Always read these safety precautions very carefully.

In the Operator's Manual warning texts have the following priority:

 **WARNING!** If these instructions are not followed there is a danger of personal injury, extensive damage to the product or serious mechanical malfunction.

 **IMPORTANT!** Used to draw your attention to something that can cause damage, product malfunction or damage to property.

NOTE! Used to draw your attention to important information that will facilitate work or operations.

 This symbol is used in certain cases on our products and refers to important information in the Operator's Manual. Ensure that warning and information symbols on the engine and transmission are always visible and legible. Replace symbols that have been damaged or painted over.

Safety precautions to be taken when operating the boat

Your new boat

Read Operator's Manuals and other information supplied with your new boat. Learn to operate the engine, controls and other equipment safely and correctly.

If this is your first boat, or is a boat type with which you are not familiar, we recommend that you practice controlling the boat in peace and quiet. Learn how the boat behaves at different speeds, weather conditions and loads before casting off for your "real" maiden voyage.

Remember that the person driving a boat is legally required to know and follow the current rules regarding traffic and safety at sea. Make sure you know the rules that apply to you and the waters you are sailing in by contacting the relevant authorities or organization.

A good piece of advice is to take a course in seamanship. We recommend that you contact your local boating organization to find a suitable course.

Accidents

Statistics show that poor maintenance of boats and engines and a lack of safety equipment are often the cause of accidents at sea.

Ensure that your boat is maintained in accordance with the relevant Operator's Manual and that the necessary safety equipment is on-board and is serviceable.

Daily checklist

Make a habit of checking the engine and engine compartment visually before operating the boat (**before the engine is started**) and after operating the boat (**after the engine has been stopped**). This will help you to quickly detect fuel, coolant and oil leaks and spot anything else unusual that has, or is about to happen.

Maneuvering

Avoid violent and unexpected changes in course and gear engagement. This could cause someone on the boat to lose their balance and fall over or overboard.

A rotating propeller can cause serious injury. Check that nobody is in the water before engaging ahead or astern. Never drive near bathers or in areas where people could be in the water.

Avoid trimming an outboard drive too much, as steering will be severely reduced.

Refueling

When refueling there is always a danger of fire and explosion. Smoking is forbidden and the engine must be switched off.

Never overfill the tank. Close the fuel tank filler cap properly.

Only use the fuel recommended in the Operator's Manual. The wrong grade of fuel can cause operating problems or cause the engine to stop. On a diesel engine poor quality fuel can cause the control rod to seize and the engine to overrev with a resultant risk of damage to the engine and personal injury.

Do not start the engine

Do not start or run the engine with a suspected fuel or LPG leak in the boat, when you are close to or in a discharge of explosive media, etc. There is a risk for fire and/or explosion in explosive surroundings.

⚠ Carbon monoxide poisoning

When a boat is moving forward backwash is caused behind the boat. Sometimes this backwash can be so powerful that exhaust gases can be sucked into the cabin or seating well on the boat with the resulting risk of carbon monoxide poisoning for those on board.

The backwash problem is greatest with high, broad boats with a squared stern. But other types of boat can also have backwash problems under certain conditions, for example when running with an awning rigged. Among other factors that can increase the backwash effect are wind conditions, load distribution, the sea running, trim, open hatches and valves.

Most modern boats are designed in such a way that problems with backwash are extremely unusual. Should a backwash problem occur do not open hatches or valves in the forward part of the boat. This will only increase backwash. Try changing speed, trim or load distribution in the boat instead. In addition take down, open or change the rigging of the awning in some other way if an awning is rigged. Contact the dealer where the boat was purchased to get more information on how to solve this problem should it occur on your boat.

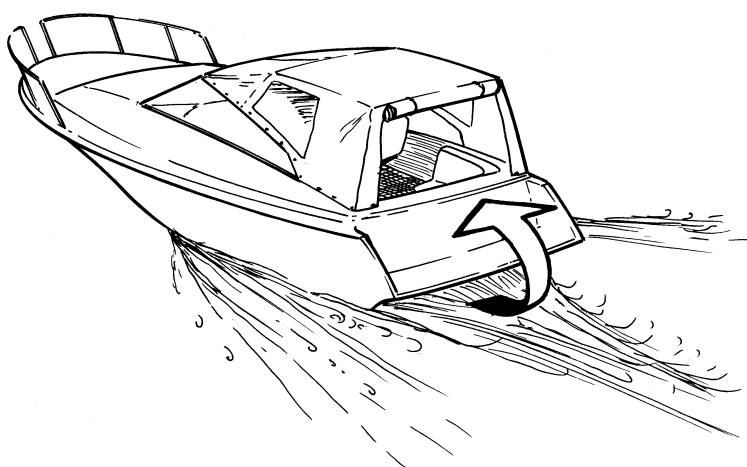

⚠ Checklist

- Safety equipment: Life jackets for all passengers, communication equipment, emergency rockets, approved fire extinguisher, first-aid equipment, life belt, anchor, paddle, torch etc.
- Replacement parts and tools: impeller, fuel filters, fuses, tape, hose clamps, engine oil, propeller and tools for any repairs that might have to be carried out.
- Get out your charts and go over the planned route. Calculate distance and fuel consumption. Listen to the weather reports
- Make sure that relations or contact persons are informed when planning a longer voyage. Remember to inform them if your plans have changed or been delayed.
- Tell your passengers and crew where the safety equipment is stored and how to operate it. Make sure you are not the only person on board who knows how to start the boat and operate it safely.

The list should be supplemented because the requirement for safety equipment varies depending on the boat type and how it is used etc. We recommend that you contact a local boating or maritime safety organization for more detailed marine safety information.

Safety precautions for maintenance and service operations

Preparations

Knowledge

The Operator's Manual contains instructions on how to carry out general maintenance and service operations safely and correctly. Read the instructions carefully before starting work.

Service literature covering more complicated operations is available from your Volvo Penta dealer.

Never carry out any work on the engine if you are unsure of how it should be done, contact your Volvo Penta dealer who will be glad to offer assistance.

Stop the engine

Stop the engine before opening or removing engine hatches. Unless otherwise specified all maintenance and service must be carried out with the engine stopped.

To prevent accidental start of the boat engine remove the ignition key, turn off the power supply to the engine at the main switch and lock it in the OFF position before starting work. Put up a warning sign in the control position that work on the engine is being carried out.

Approaching or working on an engine that is running is a safety risk. Loose clothing, hair, fingers or a dropped tool can be caught in the rotating parts of the engine and cause serious personal injury. Volvo Penta recommend that all servicing with the engine running be undertaken by an authorized Volvo Penta workshop.

Lifting the engine

When lifting the engine use the lifting eyes installed on the engine (reverse gear where installed). Always check that lifting equipment is in good condition and is strong enough for the lift (engine weight with any extra equipment). For safety's sake lift the engine using an adjustable lifting beam. All chains and cables should run parallel to each other and as perpendicular as possible in relation to the top of the engine. Bear in mind that extra equipment installed on the engine may alter its center of gravity. Special lifting equipment may then be required in order to maintain the correct balance and make the engine safe to handle. Never carry out work on an engine suspended on a hoist.

Before starting the engine

Reinstall all guards removed during service operations before starting the engine. Check that no tools or other items have been left on the engine.

Never start a turbocharger engine without installing the air cleaner (ACL). The rotating compressor in the turbocharger can cause serious personal injury. Foreign objects can also be sucked in and cause mechanical damage to the unit.

Fire and explosion

Fuel and lubrication oil

All fuel, most lubricants and many chemicals are inflammable. Read and follow the instructions on the packaging.

When carrying out work on the fuel system make sure the engine is cold. A fuel spill onto a hot surface or electrical components can cause a fire.

Store fuel soaked rags and other flammable material so that there is no danger of them catching fire. In certain conditions oil-soaked rags can spontaneously ignite.

Do not smoke when filling fuel, oil or in proximity of a filling station or in the engine room.

Non-original components

Components used in the fuel and ignition system (gasoline engines) and electrical systems on Volvo Penta products are designed and constructed to minimize the risk of fire and explosion.

Using non-original Volvo Penta parts can result in fire or explosion on board.

Batteries

The batteries contain and give off oxyhydrogen gas, especially during charging. This gas is easily ignited and highly flammable.

Do not under any circumstances smoke or use naked flame or allow sparks in the vicinity of the batteries or battery compartment.

Incorrectly connecting a battery terminal cable or jump-start cable can cause a spark which in turn can be sufficient to cause an explosion.

Start spray

Never use start spray or similar agents to start an engine equipped with air pre-heating (glow plugs/ starter element). The starter element may cause an explosion in the inlet manifold. Danger of personal injury.

Hot surfaces and fluids

There is always a risk of burns when working with a hot engine. Beware of hot surfaces. For example: the exhaust pipe, turbocharger (TC), oil pan, charge air pipe, starter element, hot coolant and hot oil in oil lines and hoses.

Carbon monoxide poisoning

Start the engine only in a well-ventilated area. If operating the engine in an enclosed space, ensure that there is proper ventilation in order to remove exhaust gases and crankcase ventilation emissions from the working area.

Chemicals

Most chemicals such as anti-freeze, rustproofing agent, inhibiting oil, degreasing agent etc. are hazardous to health. Read and follow the instructions on the packaging.

Some chemicals such as inhibiting oil are inflammable and dangerous if breathed in as well. Ensure good ventilation and use a protective mask when spraying. Read and follow the instructions on the packaging.

Store chemicals and other hazardous materials out of the reach of children. To protect the environment please dispose of used or leftover chemicals at a properly designated disposal site for destruction.

Cooling system

There is a risk of water penetration when working on the seawater system. Turn off the engine and close the sea cock before starting work on the system.

Avoid opening the coolant filler cap when the engine is hot. Steam or hot coolant can spray out and cause burns.

If work must be carried out with the engine at operating temperature and the coolant filler cap or a cock open or a coolant hose disconnected, open the coolant filler cap carefully and slowly to release pressure before removing the cap completely. Note that the coolant may still be hot and can cause burns.

Lubrication system

Hot oil can cause burns. Avoid skin contact with hot oil. Ensure that the lubrication system is not under pressure before commencing work on it. Never start or operate the engine with the oil filler cap removed, oil can spray out.

Fuel system

Always use protective gloves when tracing leaks. Liquids ejected under pressure can penetrate body tissue and cause serious injury. There is a danger of blood poisoning.

Always cover the generator if it is located under the fuel filter. The generator can be damaged by spilled fuel.

Electrical system

Cutting off power

Always stop the engine and break the current using the main switches before working on the electrical system. Isolate shore current to the engine block heater, battery charger, or accessories mounted on the engine.

Batteries

The batteries contain an extremely corrosive electrolyte. Protect your skin and clothes when charging or handling batteries. Always use protective goggles and gloves.

If battery electrolyte comes into contact with unprotected skin wash off immediately using plenty of water and soap. If battery acid comes into contact with the eyes, flush immediately with plenty of water and obtain medical assistance without delay.

Introduction

This Operator's Manual has been compiled to help you get the most from your Volvo Penta engine. It contains all the information you need in order to operate and maintain your engine safely and correctly. Please read the Operator's Manual carefully and learn how to operate the engine, controls and other equipment safely.

Always have the Operator's Manual available. Keep it in a safe place and do not forget to give it to the new owner if you sell your boat.

Care of the environment

We would all like to live in a clean and healthy environment. Somewhere where we can breathe clean air, see healthy trees, have clean water in our lakes and oceans, and are able to enjoy the sunshine without being worried about our health. Unfortunately, this cannot be taken for granted nowadays but is something we must work together to achieve.

As a manufacturer of marine engines, Volvo Penta has a special responsibility, why care of the environment is a core value in our product development. Today, Volvo Penta has a broad range of engines where progress has been made in reducing exhaust emissions, fuel consumption, engine noise, etc.

We hope you will take care in preserving these qualities. Always follow any advice given in the Operator's Manual concerning fuel grades, operation and maintenance and you will avoid causing unnecessary interference to the environment. Get in touch with your Volvo Penta dealer if you notice any changes such as increased fuel consumption exhaust smoke.

Adapt speed and distance to avoid wash and noise disturbing or injuring animal life, moored boats, jetties, etc. Leave islands and harbours in the same condition as you want to find them. Remember to always leave hazardous waste such as waste oil, coolant, paint and wash residue, flat batteries, etc., for disposal at a destruction plant.

Our joint efforts will make a valuable contribution to our environment.

Running-in

The engine must be run in for its first 10 operating hours as follows:

Operate the engine normally. Do not operate it at full load except for short periods. Never run the engine at a constant engine speed for long periods during the running-in period.

The engine can be expected to use more engine oil during the running-in period than would otherwise be normal. Check the oil level more often than is normally recommended.

The prescribed warranty inspection "First Service Inspection" must be carried out during this first period of operation. For more information: See the Warranty and Service Book.

Fuel and oils

Only use the fuel and oils recommended in the chapter Technical Data. Other grades of fuel and oil can cause operating problems, increased fuel consumption and, in the long-term, a shorter engine service life.

Always change oil, oil filters and fuel filters at the recommended intervals.

Service and replacement parts

Volvo Penta marine engines are designed for high operational reliability and long service life. They are constructed to withstand the marine environment while also affecting it as little as possible. Through regular service and the use of Volvo Penta original spare parts, these qualities will be retained.

The Volvo Penta worldwide network of authorized dealers are at your service. They are specialists in Volvo Penta products and have accessories and the original replacement parts, test equipment and special tools necessary for high quality service and repair work.

Always follow the maintenance intervals contained in the Operator's Manual. Remember to state the engine/transmission identification number when ordering service and replacement parts.

Certified engines

It is important to be aware of the following information if you own or run an engine that is exhaust emission certified:

Certification means that an engine type is inspected and approved by the authorities. The engine manufacturer guarantees that all engines manufactured of that type correspond to the certified engine.

This places special requirements for maintenance and service as follows:

- The maintenance and service intervals recommended by Volvo Penta must be observed.
- Only genuine Volvo Penta replacement parts may be used.
- The service of injection pumps and injectors or pump settings must always be carried out by an authorized Volvo Penta workshop.

- The engine must not be modified in any way except with accessories and service kits approved by Volvo Penta.
- No modifications to the exhaust pipes and air supply ducts for the engine may be undertaken.
- Seals may only be broken by authorized personnel.

Otherwise the general instructions contained in the Operator's Manual concerning operation, service and maintenance must be followed.

⚠ IMPORTANT! Late or inadequate maintenance/service or the use of spare parts other than Volvo Penta original spare parts will invalidate AB Volvo Penta's responsibility for the engine specification being in accordance with the certificated variant.

Volvo Penta accepts no responsibility or liability for any damage or costs arising due to the above.



Warranty

Your new Volvo Penta marine engine is covered by a limited warranty according to the conditions and instructions contained in the Warranty and Service book.

Note that AB Volvo Penta's liability is limited to that contained in the Warranty and Service Book. Read this book as soon as you take delivery of the engine. It contains important information about warranty cards, service and maintenance which you, the owner, must be aware of, check and carry out. Liability covered in the warranty may otherwise be refused by AB Volvo Penta.

Contact your Volvo Penta dealer if you have not received a Warranty and Service Book and a customer copy of the warranty card.

Presentation

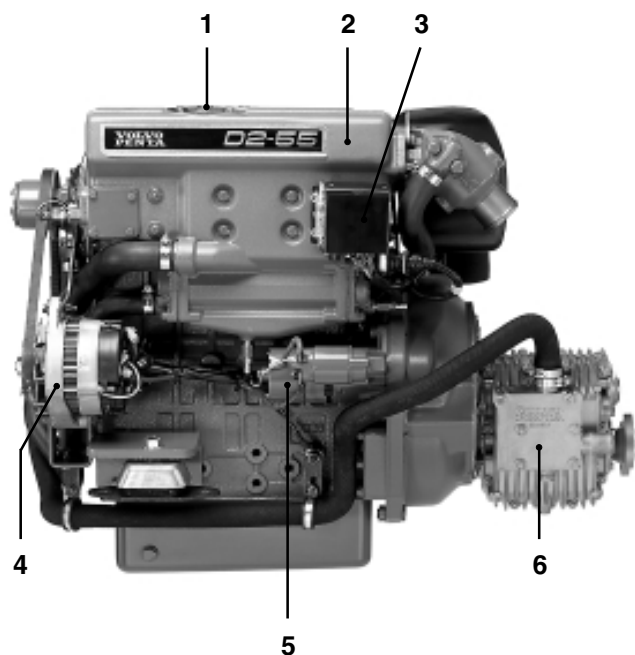

D2-55 with reverse gear MS25L

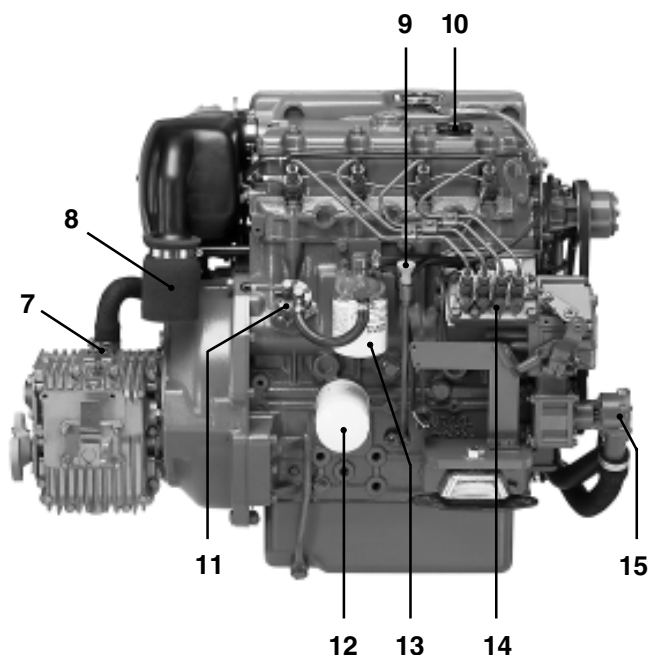

D2-55 with reverse gear MS25L

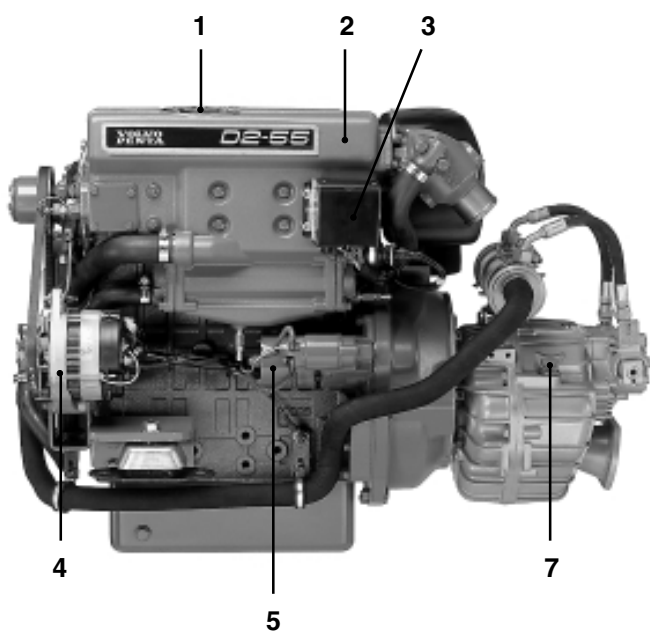

D2-55 with reverse gear HS25A

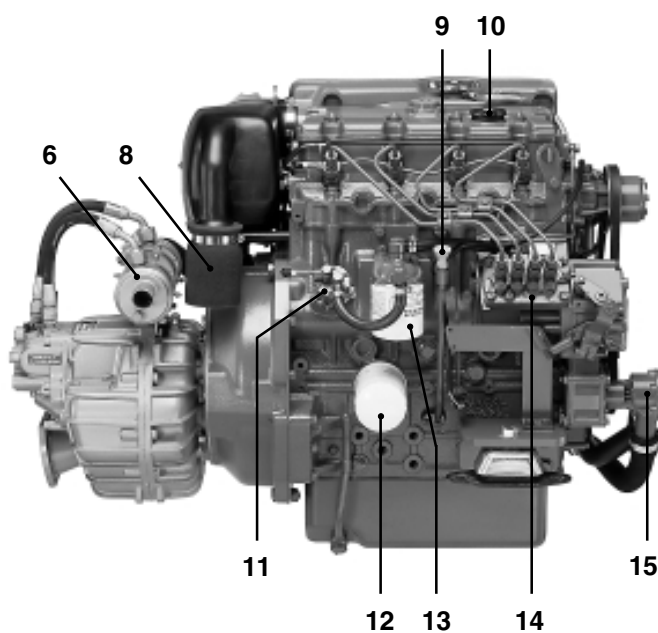

D2-55 with reverse gear HS25A

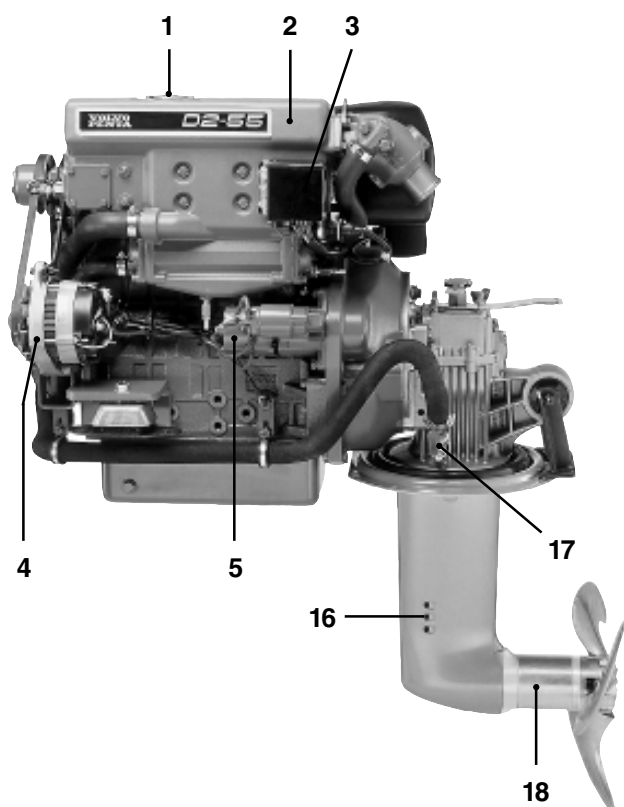

D2-55 with sailing boat drive MS25S

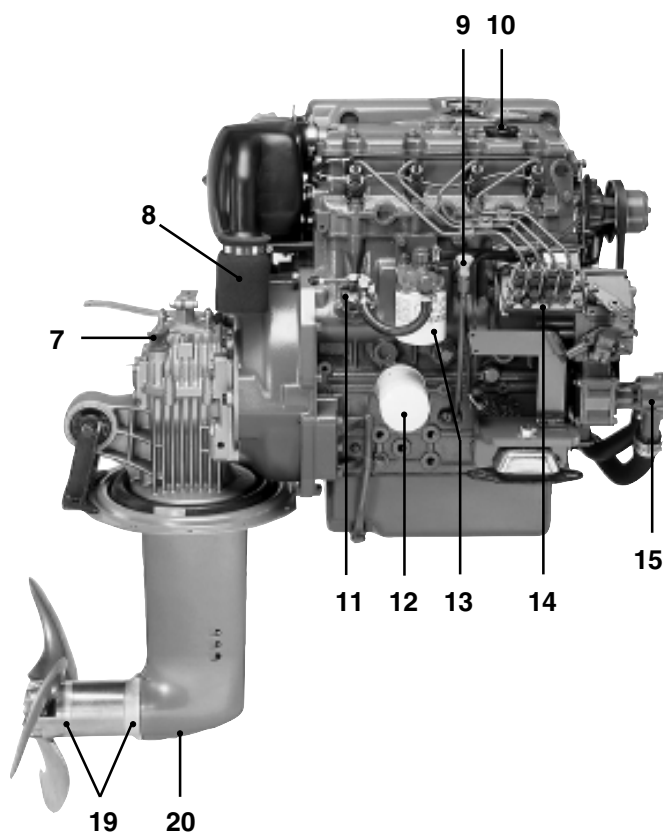

D2-55 with sailing boat drive MS25S

- 1. Coolant filler cap
- 2. Heat exchanger
- 3. Relay box with fuses
- 4. Generator
- 5. Starter motor
- 6. Oil cooler, reverse gear
- 7. Dipstick, reverse gear/S-drive

- 8. Air cleaner (ACL)/Air intake
- 9. Dipstick, engine
- 10. Oil filler cap, engine
- 11. Fuel pump
- 12. Oil filter
- 13. Fuel filter
- 14. Injection pump

- 15. Seawater pump
- 16. Cooling water intake, S-drive
- 17. Sea cock, S-drive
- 18. Folding propeller
- 19. Sacrificial anodes
- 20. Oil drain plug, S-drive

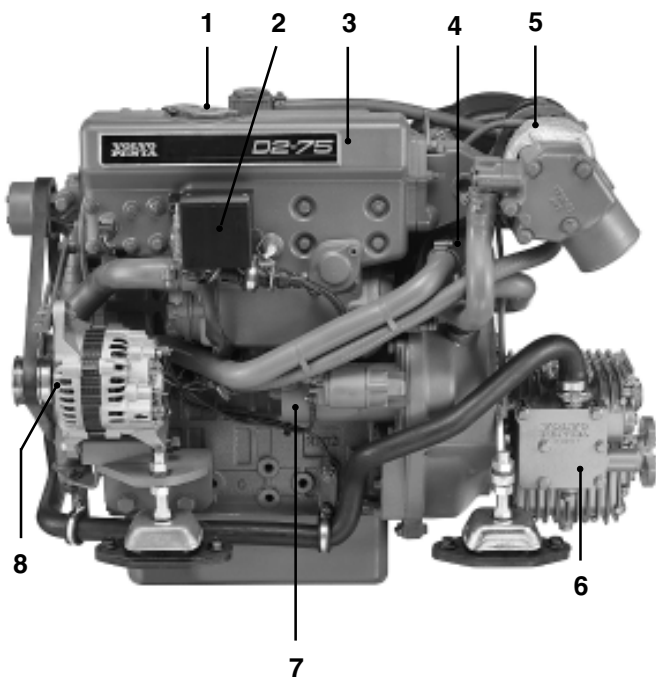

D2-75 with reverse gear MS25L

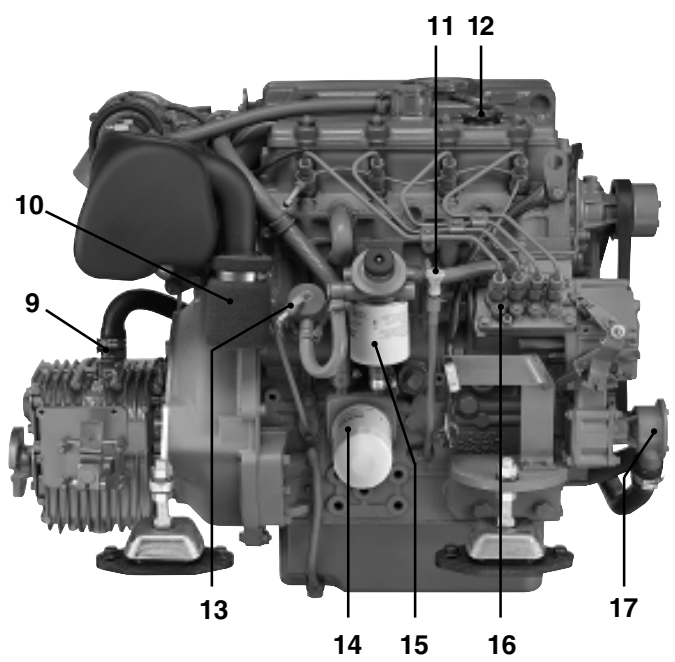

D2-75 with reverse gear MS25L

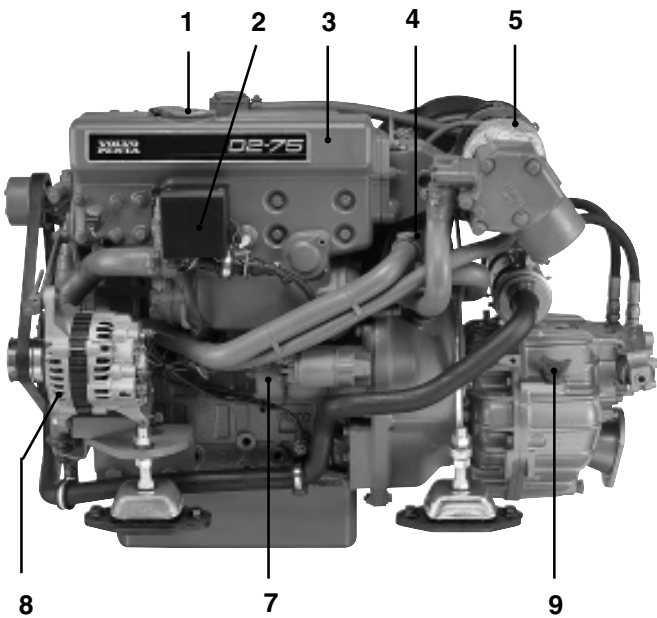

D2-75 with reverse gear HS25A

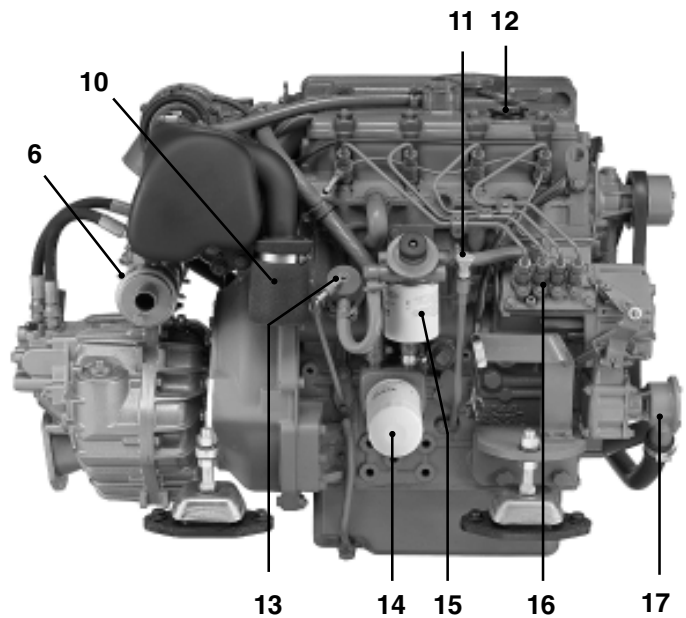

D2-75 with reverse gear HS25A

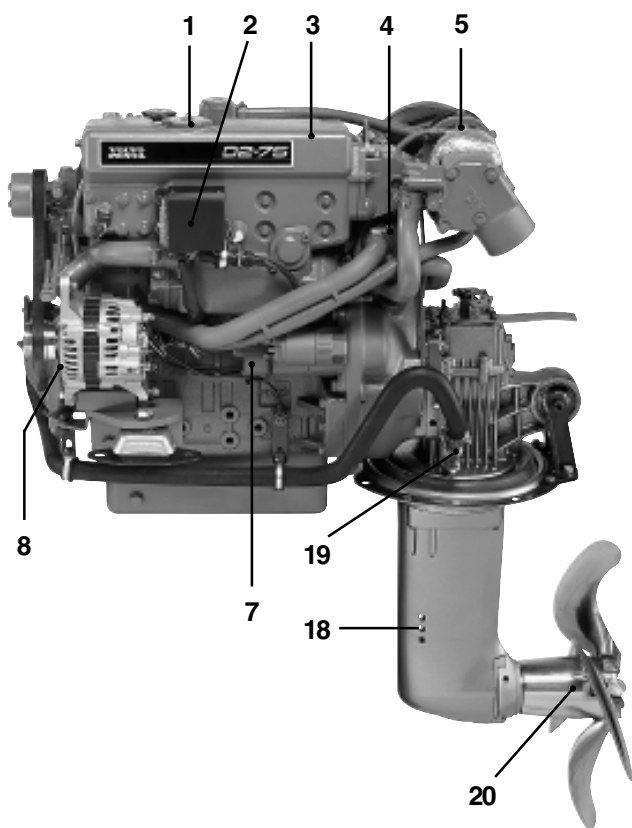

D2-75 with sailing boat drive 150S

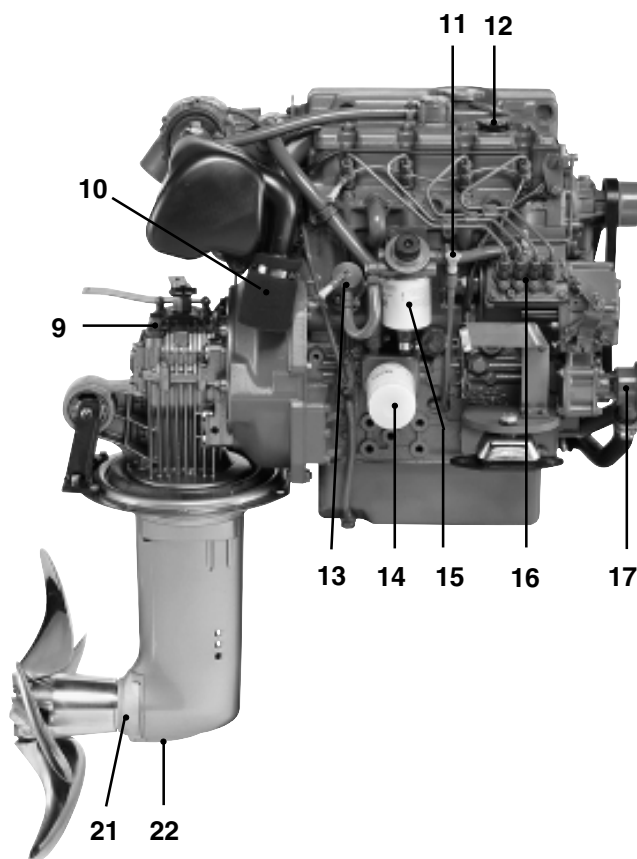

D2-75 with sailing boat drive 150S

- 1. Coolant filler cap
- 2. Relay box with fuses
- 3. Heat exchanger
- 4. Charge air cooler
- 5. Turbo
- 6. Oil cooler, reverse gear
- 7. Starter motor

- 8. Generator
- 9. Dipstick, reverse gear/S-drive
- 10. Air cleaner (ACL)/Air intake
- 11. Dipstick, engine
- 12. Oil filler cap, engine
- 13. Fuel pump
- 14. Oil filter

- 15. Fuel filter
- 16. Injection pump
- 17. Seawater pump
- 18. Cooling water intake, S-drive
- 19. Sea cock, S-drive
- 20. Folding propeller
- 21. Sacrificial anodes
- 22. Oil drain plug, S-drive

Identification number

Your engine and transmission has identification plates with identification numbers. This information should always be quoted when ordering service and replacement parts. There are probably similar plates on your boat and its equipment. Make a note of the details below, make a copy of the page and keep it so that you have a copy should the boat be stolen.

The appearance and location of identification plates is shown below. The figures in brackets refer to the location of the identification numbers on the identification plate.

Engine

Product designation (1)

Serial number (2)

Product number (3)

Certification number (4)

S-drive/Reverse gear

Product designation (5)

Serial number (6)

Product number (7)

Gear ratio (8)

Propeller designation



Engine and transmission decal



S-drive and reverse gear

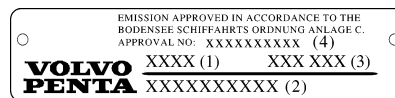
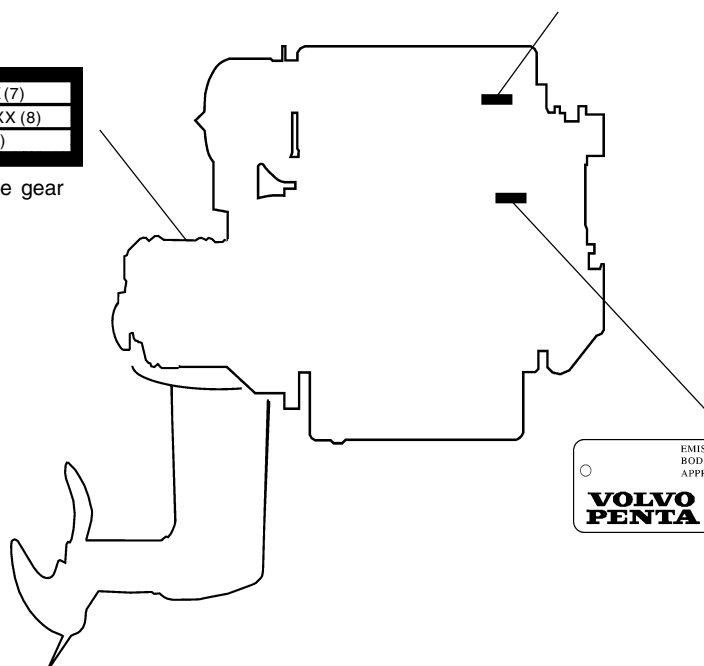

Engine plate

Instrumentation

This chapter only describes the instrument panels available as standard alternatives for your engine from Volvo Penta. Note that in certain boats instruments, alarm panels, key switches etc. may be installed separately without the instrument panels shown here.

If you want to install additional instrumentation, or your boat is equipped with instruments not described here, please contact your Volvo Penta dealer.

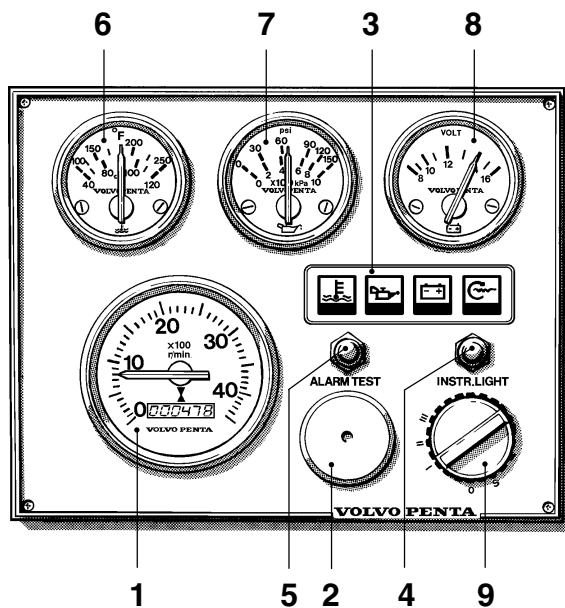

Instrument panel with ignition switch

1. Tachometer and hour counter (accessory). Displays engine speed. Multiply this value by 100 for revolutions per minute. The hour counter displays engine operating time in hours and tenths of an hour.
2. Siren for acoustic alarm.
3. Warning display. See pos. 22-25.
4. Switch for instrument lighting.
5. Alarm test/acknowledgment switch.

To test alarm: Press the switch. All warning lights light and the acoustic alarm sounds.

Alarm acknowledgment: Press the switch if there is an alarm. The acoustic alarm stops but the relevant warning lamp continues to flash until the malfunction is corrected.

6. Temperature gauge. Displays the engine coolant temperature.
7. Oil pressure gauge. Displays the oil pressure in the engine.
8. Voltmeter. Displays the charge voltage from the generator.
9. Ignition switch. See description in the next chapter.

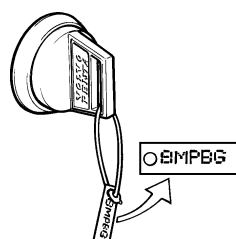
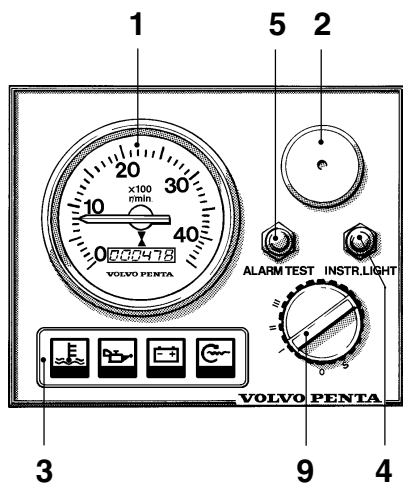

Ignition switch

The starter keys are tagged with a key code. This code must be quoted when ordering extra keys. Keep the code where it is **not** available to unauthorized persons.

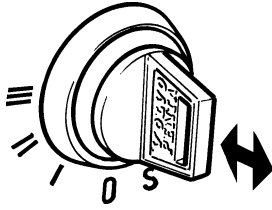

- S = The mechanical restart inhibitor is disengaged. The key springs back automatically to the 0 position.
- 0 = The key can be inserted and removed.
- I = Operating position.
- II = Glow plug position. The glow plugs are connected and pre-heating the engine.
- III = Start position. The starter motor is engaged.

⚠ IMPORTANT! Read the starting instructions in the chapter: Starting the engine.

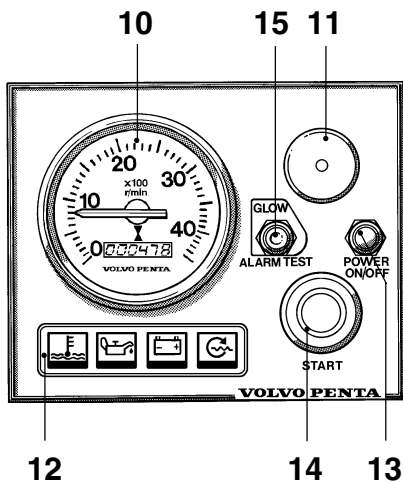

Instrument panel without ignition switch

The instrument panel does not have an ignition switch. To stop unauthorized persons starting the engine the wheelhouse should have a lock or a lockable main switch should be used.

- 10. Tachometer and hour counter (accessory). Displays engine speed. Multiply this value by 100 for revolutions per minute. The hour counter displays engine operating time in hours and tenths of an hour.
- 11. Siren for acoustic alarm.
- 12. Warning display. See pos. 22-25.
- 13. Switch for connecting and disconnecting instrument panel.
- 14. Starter button. The starter motor is engaged when this button is pressed.
- 15. Alarm test/acknowledgment and glow plug rocker switch.

Glow plugs active: When the rocker switch is in the up position the glow plugs are activated.

To test alarm: Move the rocker switch down. All warning lights light and the acoustic alarm sounds.

Alarm acknowledgment: If there is an alarm the rocker switch is moved down and the alarm is acknowledged. The acoustic alarm stops but the relevant warning lamp continues to flash until the malfunction is corrected.

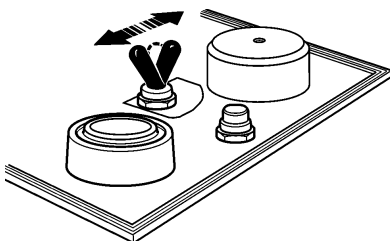

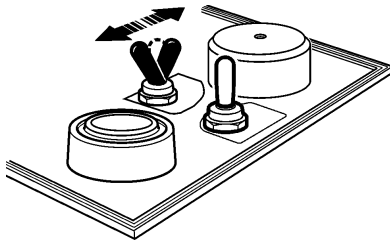
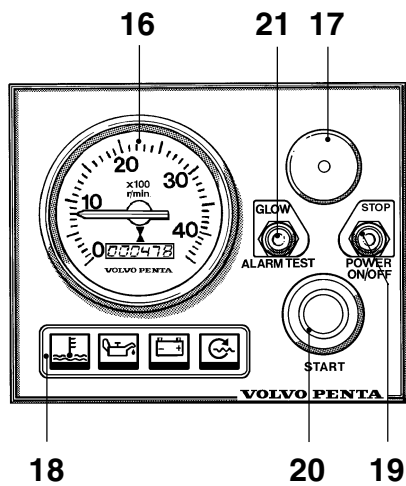

Instrument panel with electrical start/stop function

The instrument panel does not have an ignition switch. To stop unauthorized persons starting the engine the wheelhouse should have a lock or a lockable main switch should be used.

16. Tachometer and hour counter (accessory).
Displays engine speed. Multiply this value by 100 for revolutions per minute. The hour counter displays engine operating time in hours and tenths of an hour.
17. Siren for acoustic alarm.
18. Warning display. See pos. 22-25.
19. Rocker switch for connecting/disconnecting the instrument panel and stop function.
20. Starter button. The starter motor is engaged when this button is pressed.
21. Alarm test/acknowledgment and glow plug rocker switch.

Glow plugs active: When the rocker switch is in the up position the glow plugs are activated.

To test alarm: Move the rocker switch down. All warning lights light and the acoustic alarm sounds.

Alarm acknowledgment: If there is an alarm the rocker switch is moved down and the alarm is acknowledged. The acoustic alarm stops but the relevant warning lamp continues to flash until the malfunction is corrected.

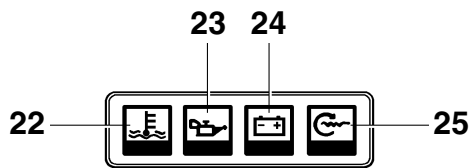

Warning display

If the acoustic alarm sounds, one of the three warning lamps (22-24) on the instrument panel starts to flash to indicate the source of the alarm.

22. Engine coolant temperature too high.

⚠ IMPORTANT! If the alarm sounds: Reduce engine speed to idle (neutral). Stop the engine if the temperature does not drop. Investigate and correct the malfunction.

23. Low oil pressure.

⚠ IMPORTANT! If the alarm sounds: Stop the engine immediately and investigate.

24. Generator not charging.

25. Indicator lamp Comes on when the glow plugs are activated.

Check that the warning lamps are operating before starting the engine according to the description of the relevant instrument panel.

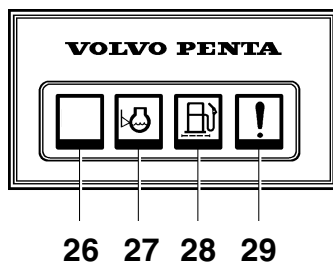

Extra warning display

If the acoustic alarm sounds, one of the four warning lamps starts to flash to indicate the source of the alarm. The extra warning display is an accessory.

26. Not used.

27. Low coolant level. Top up to correct level before starting.

28. Water in extra fuel pre-filter. Drain off water in filter. See instructions in the chapter Maintenance.

29. Extra alarm for an optional function.

Controls

The shift function and engine speed control are combined in one lever. If necessary the shift function can be easily disengaged so that only the engine speed (rpm) is affected by the lever. The control lever has an adjustable friction brake. A neutral position switch is available as an accessory, this will only permit the engine to be started with the drive/reverse gear disengaged.

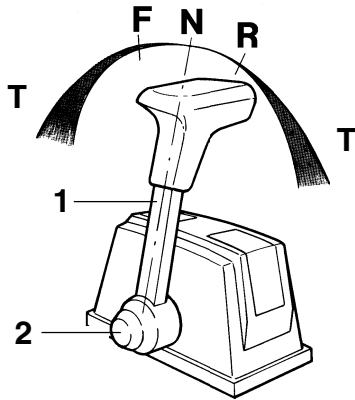

For top-mounted controls

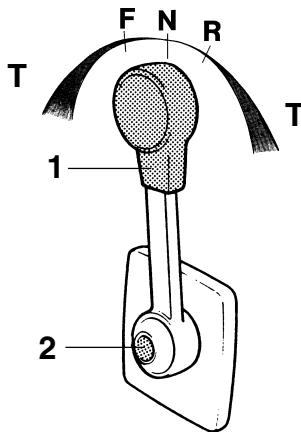

For side-mounted controls

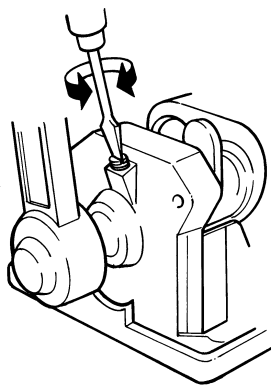

Maneuvering

Shifting and engine speed are controlled with the same lever (1).

N = Neutral position. Drive/reverse gear disengaged.

F = Drive/reverse gear engaged for movement ahead.

R = Drive/reverse gear engaged for movement astern.

T = Engine speed control

Disengaging the shift function

- Move lever (1) to the neutral position (N).
- Press in button (2), move the lever slightly forward and release the button.

The shift function is now disengaged and the lever affects only engine speed. When the lever is moved back to the neutral position it will automatically re-engage.

⚠ IMPORTANT! Take care not to engage the drive/reverse gear by mistake.

Adjusting the friction brake

The friction brake only affects the engine speed control movements.

- Lift the cover over the control. For side-mounted controls the lever must first be removed.
- Set the lever to the half-open throttle/reverse position.
- Adjust the friction brake. Turning the screw clockwise (+) makes the lever movement stiffer, while turning counterclockwise (-) makes it easier to move the lever.
- Reinstall the cover and lever.

Starting the engine

Make a habit of checking the engine and engine compartment visually before operating the boat. This will help you to quickly detect anything unusual that has or is about to happen. Also check that instruments and the warning display are indicating normal values when you have started the engine.

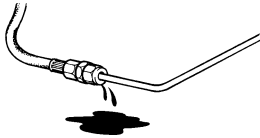
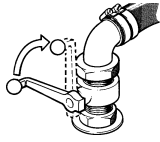

Before starting

- Open the cooling water intake sea cock.
- Open fuel cock.
- Carry out the actions in the “Daily before the first start-up” section in the maintenance schedule
- Switch on the main switch.
⚠ IMPORTANT! Never break the circuit with the main switch while the engine is running. This could damage the generator.
- Start the engine compartment fan if one is fitted and let it run for at least four minutes.
- Check that there is sufficient fuel.
- Push in the stop control, if the boat is fitted with one.

Starting. Instrument panel with ignition lock

⚠ WARNING! Never use start spray or similar to start the engine. Danger of explosion!

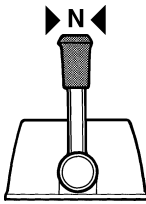

1. **If the engine is cold:** Disconnect the gear shift function and move the control lever forwards to half throttle.

⚠ WARNING! Make sure that the gear shift function is disconnected.

If the engine is warm: Move the control lever to the neutral/idling position.



2. Insert the key in the ignition switch. Turn key to the "I" position. The three warning lamps come on and can be tested.

Check that the acoustic alarm is operating by pressing the "Alarm Test" button.

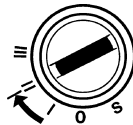

3. Turn key to the "II" position. The indicator light comes on and the glow plugs are connected to pre-heat the engine. Let the glow plugs remain activated for 10 seconds (max. 30 seconds).

⚠ IMPORTANT! Always pre-heat the engine (even when it is warm).

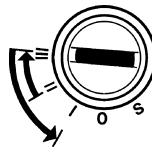

4. Turn the key to position "III" to start. Release the key as soon as the engine has started, the key will automatically spring back to the "I" position.

⚠ IMPORTANT! If the starter motor is engaged for its maximum engagement time (20-30 seconds) let it cool down for five minutes before trying to start the engine again.

5. Warm up the engine at low speed and low load.

⚠ IMPORTANT! Do not race the engine while it is cold.

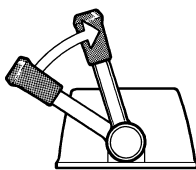

Starting. Instrument panel without ignition switch

⚠ WARNING! Never use start spray or similar to start the engine.
Danger of explosion!

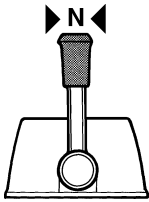

1. **If the engine is cold:** Disconnect the gear shift function and move the control lever forwards to half throttle.

⚠ WARNING! Make sure that the gear shift function is disconnected.

If the engine is warm: Move the control lever to the neutral/idling position.

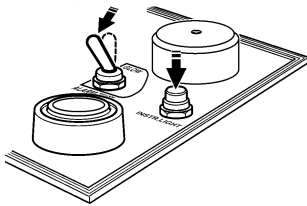

2. **Instrument panel without ignition switch:**

Activate the instrument panel by pressing the "Power ON/OFF" switch. The three warning lamps come on and can be tested.

Check that the acoustic alarm is operating by pushing the rocker switch to the "Alarm Test" position.

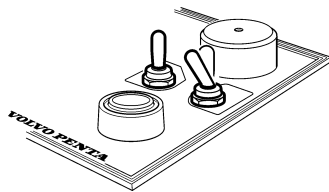

Instrument panel with electrical start/stop function:

Activate the instrument panel by pressing the rocker switch downwards to "Power ON/OFF". The three warning lamps come on and can be tested.

Check that the acoustic alarm is operating by pushing the rocker switch to the "Alarm Test" position.

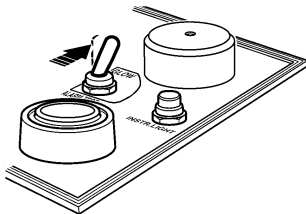

3. Push the rocker switch to the "Glow" position. The indicator light comes on and the glow plugs are connected to pre-heat the engine. Let the glow plugs remain activated for 10 seconds (max. 30 seconds).

⚠ IMPORTANT! Always pre-heat the engine (even when it is warm).

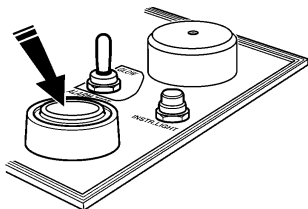

4. Press the starter button. Release the starter button as soon as the engine starts.

⚠ IMPORTANT! If the starter motor is engaged for its maximum engagement time (20-30 seconds) let it cool down for five minutes before trying to start the engine again.

5. Warm up the engine at low speed and low load.

⚠ IMPORTANT! Do not race the engine while it is cold.

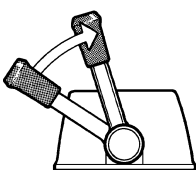

Starting using auxiliary batteries

⚠ WARNING! Batteries produce oxyhydrogen. This gas is easily ignited and highly volatile. A short-circuit, naked flame or spark can cause a large explosion. Ensure that the ventilation is good.

Never mix up battery positive and negative terminals. This may cause sparks and an explosion.

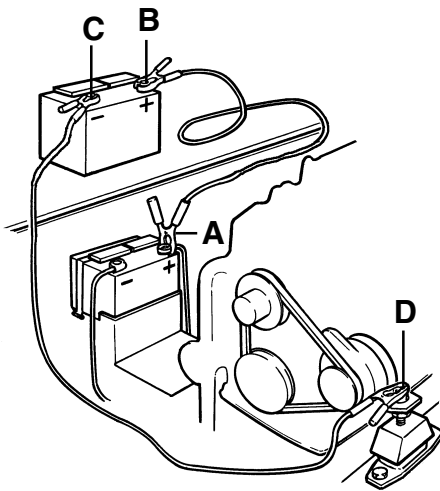

1. Check the auxiliary batteries have the same rated voltage as the engine's system voltage.
2. First connect the red jump lead to the discharged battery's **+ terminal (A)** and then to the auxiliary battery's **+ terminal (B)**.
3. First connect the black jump lead to the auxiliary battery's **- terminal (C)** and then to a site (D) where there is good contact with the cylinder block as far away from the discharged battery as possible.
4. Start the engine and run it at a fast idle for approximately ten minutes to charge the battery.

⚠ WARNING! Approaching or working on a running engine is dangerous. Watch out for rotating components and hot surfaces.

Do not touch the connections while trying to start the engine: This may cause sparks. Do not lean over the batteries.

5. Stop the engine. Remove the jump leads in **exactly** the opposite order to which you put them on.

Operation

Avoid violent and unexpected changes in course and gear engagement. There is a risk that someone aboard will fall over or overboard.

⚠ WARNING! A rotating propeller can cause serious injury. Check that nobody is in the water before engaging ahead or astern. Never drive near bathers or in areas where people could be in the water.

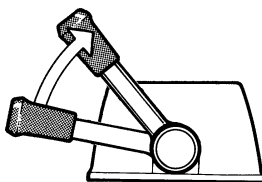
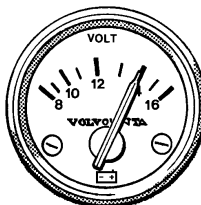
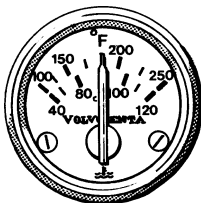
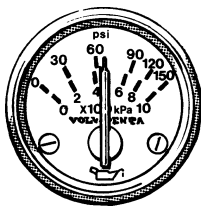
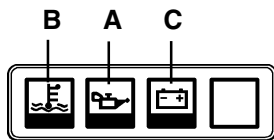

Checking instruments

Check the instruments and warning display directly after starting the engine and then at regular intervals while driving the boat. Stop the engine if there is an abnormal reading or any warning lamp comes on and the alarm sounds. For engines with measuring instruments the following standard values apply:

Oil pressure (A)

Normal operating oil pressure is between 150–500 kPa (21–71 psi). At engine idle this is normally lower. The acoustic alarm will automatically go off if the oil pressure is too low.

⚠ IMPORTANT! If the alarm sounds: Stop the engine immediately. Investigate and correct the malfunction.

Engine coolant temperature (ECT) (B)

Normal operating temperature is between 75–90°C. The acoustic alarm will automatically go off if the engine coolant temperature (ECT) is too high.

⚠ IMPORTANT! If the alarm sounds: Reduce engine speed to idle (neutral). Stop the engine if the temperature does not drop. Investigate and correct the malfunction.

Charging (C)

The operating charge current is approx. 14 V. When the engine is stopped battery voltage is approx. 12 V.

Cruising speed

Operating the engine at wide open throttle (WOT) should be avoided since it is both uneconomical and uncomfortable. Volvo Penta recommends a cruising speed in the range 500–1000 rpm lower than maximum rpm at WOT. Depending on hull type, choice of propeller, load and conditions etc. the maximum engine speed at top speed can vary, but it should be within the WOT range.

Wide Open Throttle (WOT) range: 2,700–3,000 rpm

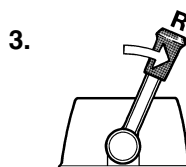
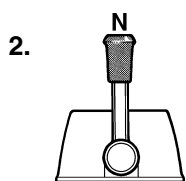
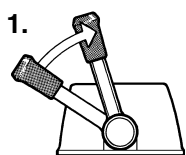

Maneuvering

All shifting between ahead and astern must be done at engine idle speed. Shifting at higher speeds may damage the drive or reverse gear and will also be uncomfortable for those on board.

1. Reduce engine speed to idling and, if possible, let the boat lose most of its speed.
2. Move the reverse gear control lever quickly and firmly into the neutral position. Wait for a moment.
3. Move the gear control lever quickly and firmly into astern, then increase the speed.

Trolling operation valve

HS25 reverse gear can be equipped with a trolling operation valve which makes it possible to steplessly reduce the boats lowest speed by 20-80% at **engine speeds up to 1200 rpm**.

 **IMPORTANT!** At engine speeds above 1200 rpm, the reversing gear can overheat.

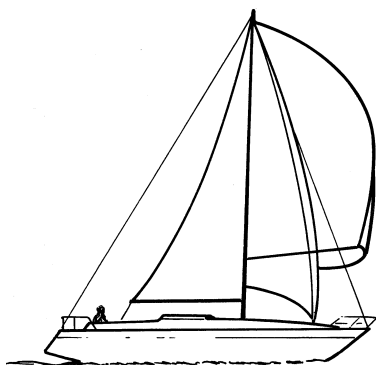

When sailing

When sailing the control lever should be in the neutral position if the boat is equipped with **HS25** reverse gear. If the boat is equipped with **S-drive** or **MS25** reverse gear the control lever should be the reverse position if a folding propeller is used and in neutral position if a fixed propeller is used.

Stopping the engine

The engine should be run for a few minutes at idle (in neutral) before turning it off. This will avoid boiling and even out the temperature. This is especially important if the engine has been operated at high engine speeds and loads.

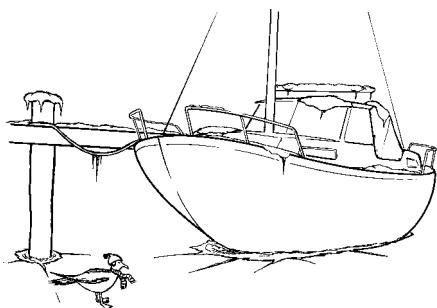
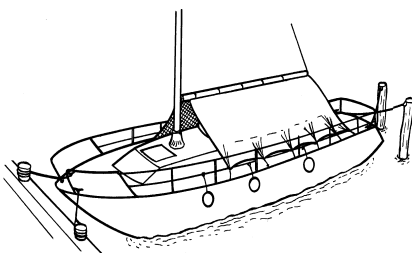
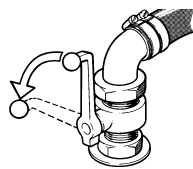
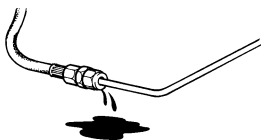
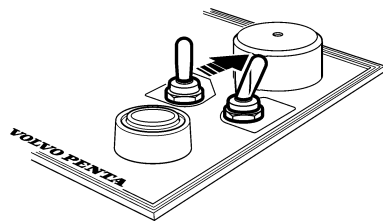
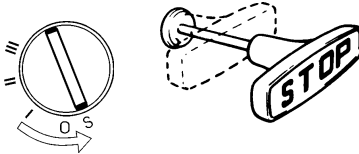

Stopping

If the boat is fitted with a stop control: Pull and hold out the stop control until the engine has stopped. Push in the stop control. If the instrument panel has an ignition switch the key should be turned to the stop position "S". The key will automatically spring back to the "0" position when it is released and can then be removed.

If the boat is fitted with an electric start/stop function: Push the rocker switch to the "Stop" position until the engine stops. Release the rocker switch and it returns automatically to the "Power OFF" position.

After stopping the engine

- Inspect the engine and engine compartment for any leaks.
 - Close the fuel cock and sea cock for the cooling water intake.
- ⚠ **IMPORTANT!** Do not forget to open the cocks before the engine is started again.
- Read off the hours counter and do preventive maintenance as in the maintenance schedule.
 - Switch off the main switch if the boat is not to be used for some time.
- ⚠ **IMPORTANT!** Never break the circuit with the main switches while the engine is running. This could damage the generator.

Laying up

If the boat is not going to be used for some time but is being left in the water, the engine must be run to operating temperature at least once every 14 days. This prevents corrosion in the engine. If the boat will not be used for more than two months then inhibiting should be carried out: See chapter "Laying up/Launching".

Cold weather precautions

To prevent freezing damage, the seawater system must be drained and the freshwater system coolant must have sufficient antifreeze protection. See chapter Maintenance "Cooling systems".

- ⚠ **IMPORTANT!** A poorly charged battery may burst as a result of freezing.

Maintenance schedule

Your Volvo Penta engine and associated equipment is designed to provide high operational reliability and long service life. They are constructed to withstand the marine environment while also affecting it as little as possible. Preventive maintenance in accordance with the maintenance schedule will ensure that it retains these qualities and avoid unnecessary operational disturbances.

Warranty inspection

The prescribed warranty inspection "First Service Inspection" must be carried out at an authorised Volvo Penta workshop during this first period of operation. Directions for when and how this is to be carried out can be found in the **Warranty and Service Book**.

MAINTENANCE SCHEDULE

 **WARNING!** Read the chapter "Maintenance" thoroughly before starting any maintenance work. It contains directions for performing maintenance in a safe and correct manner.

 **IMPORTANT!** When both operating time and calendar time is given, the one occurring first is to apply. Maintenance points marked with are to be carried out at an authorised Volvo Penta workshop.

Daily before starting for first time

- Engine and engine room. General inspection page 29
- Engine oil. Checking level page 32
- Coolant. Checking level page 34

Every 14 days

- Fuel pre-filter. Drain water page 41
- Drive belt. Check page 30
- Seawater filter. Cleaning page 37
- Battery. Check electrolyte level page 43
- Reverse gear. Check oil level page 48
- S-drive. Check oil level page 48

Least once a year

- Folding propeller. Cleaning page 50
- S-drive. Check rubber seal (hull/drive) page 52

Every 200 operating hours or at least once a year

- Reverse gear. Oil change page 49
- Reverse gear (HS25) Cleaning the oil filter page 49
- Reverse gear. Lubricate propeller shaft seal page 52
- S-drive. Oil change page 48
- S-drive/Reverse gear. Checking corrosion protection page 50

Every 500 operating hours or at least once a year

- Engine oil. Replace page 32
- Oil filter. Replace page 32
- Fuel filter. Replace page 41
- Fuel pre-filter. Replace page 41
- Idling speed. Check page 31
- Coolant¹⁾. Replace page 35
- Seawater pump. Check impeller page 36
- Vacuum valve. Cleaning page 37

¹⁾ If the freshwater system is filled with an anti-corrosion agent mixture it must be changed every year.
If the freshwater system is filled with an antifreeze (glycol) mixture it must be changed every other year.

Every 500 operating hours or at least once every two years

- Air Cleaner (ACL). Cleaning page 31
- Coolant¹⁾. Replace page 35
- Heat exchanger. Cleaning page 35
- Injectors. Test pressure not shown
- Valve clearance. Adjustment not shown

¹⁾ If the freshwater system is filled with an anti-corrosion agent mixture it must be changed every year.
If the freshwater system is filled with an antifreeze (glycol) mixture it must be changed every other year.

Every 500 operating hours or at least every fifth year

- Reverse gear. Replacing propeller shaft seal not shown

Every seventh year

- S-drive. Replacing rubber seal between drive and hull not shown

Maintenance

This chapter contains instructions regarding how the above maintenance points should be carried out together with general technical information. Read the instructions carefully before starting work. Maintenance intervals are contained in the chapter above. Maintenance schedule

⚠ WARNING! Read the safety precautions for maintenance and service in the chapter: Safety Precautions, before starting work.

⚠ WARNING! Unless otherwise specified all maintenance and service must be carried out with the engine stopped. Stop the engine before opening or removing engine hatches. Immobilize the engine by removing the ignition key, turning off the power supply with the main switch.

Engine, general

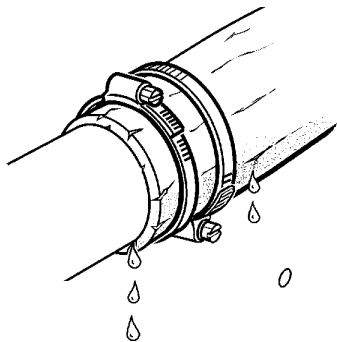
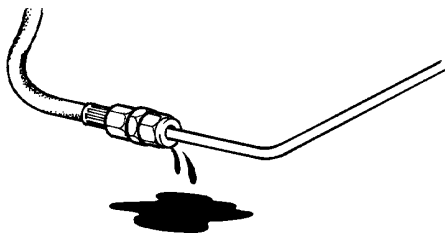

General inspection

Make a habit of “visually” inspecting the engine and engine room **before starting the engine and after stopping** when the engine has been turned off. This will help you to quickly detect abnormalities that have occurred or are about to occur.

Look especially carefully for oil, fuel and coolant leaks, loose bolts, worn or slack drive belts, loose connections, damaged hoses and electric cables. This inspection takes only a few minutes but can prevent serious operating disturbances and costly repairs.

⚠ WARNING! Accumulations of fuel, oil and grease on the engine or in the engine room is a fire hazard and must be removed immediately they are detected.

⚠ IMPORTANT! If an oil, fuel or coolant leak is detected, the cause must be investigated and the fault rectified before the engine is started.

⚠ IMPORTANT! Never point high-pressure water jets directly at seals, rubber hoses or electrical components. Never use the high-pressure function when washing the engine.

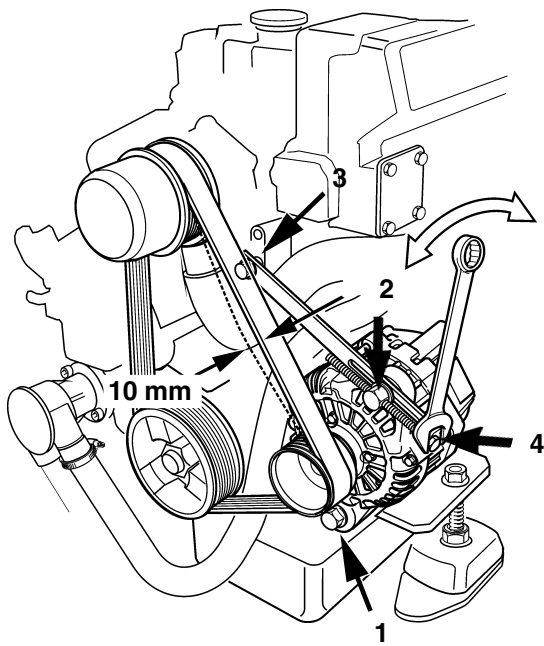

D2-75

Drive belt. Check

The belt drives both the circulation pump and the generator. A belt that is too loose can result in slippage, poor cooling and poor charging. A belt that is too tight can damage the bearings in the circulation pump and damage the generator.

Check the tension of the belt regularly. Adjust as required. Check that the belt is not cracked or damaged. Replace a worn belt. Keep a spare belt on-board.

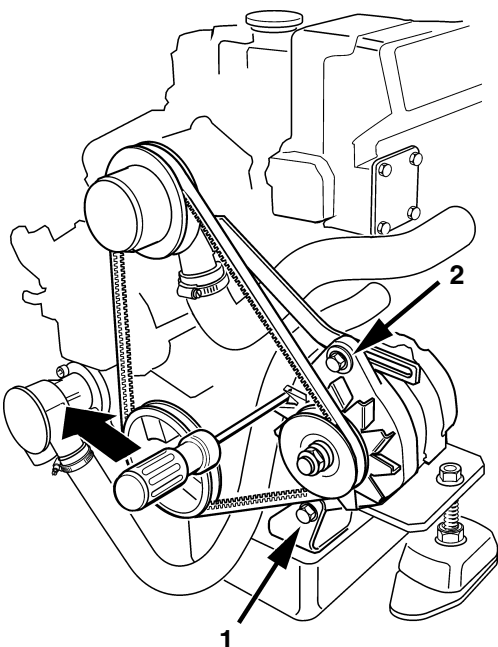

D2-55

Drive belt. Adjusting and replacing

⚠ WARNING! Always turn the engine off before starting maintenance work.

⚠ IMPORTANT! Tighten screw (1) to 50 Nm.

Check and adjust as necessary after operating the engine when the belts are warm. It should be possible to depress a belt at the correct tension approx. 10 mm between the pulleys using normal thumb pressure.

D2-55:

To adjust slacken off the screws (1 and 2). Tension the belt, adjust to the correct tension and tighten the screws. Check the tension.

D2-75:

Loosen the alternator fixing screws (1-3). Tension the belt with the adjustment screw (4), to the correct tension. Tighten the screws (1-3). Check the tension.

To replace the belt slacken off screws (1 and 2). Press the generator in towards the cylinder block so that the belt can be removed. Clean off the pulley grooves. Install the new belt. Adjust as above. Check belt tension again after a few hours' operation.

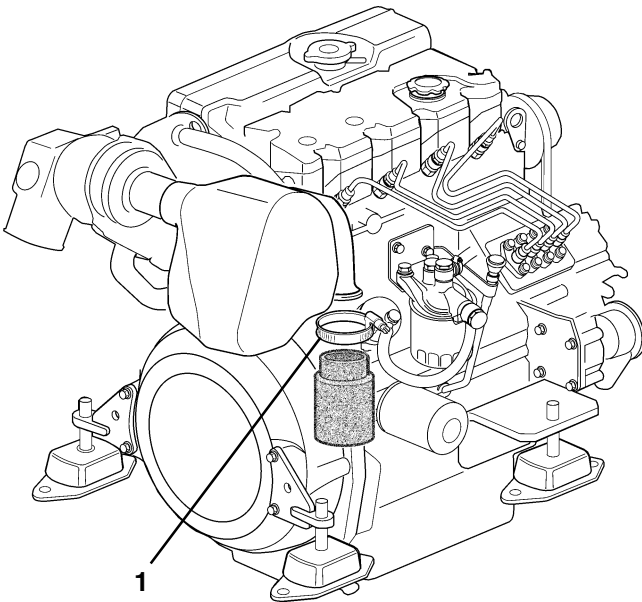

Air Cleaner (ACL). Cleaning

Remove the hose clamp (1) and remove the filter. Remove the spring inside the filter. Clean the filter as necessary by washing it in soapy water. Then rinse it in clean water. Squeeze the filter out and leave it to dry.

⚠ IMPORTANT! Take care that no contaminants enter the engine.

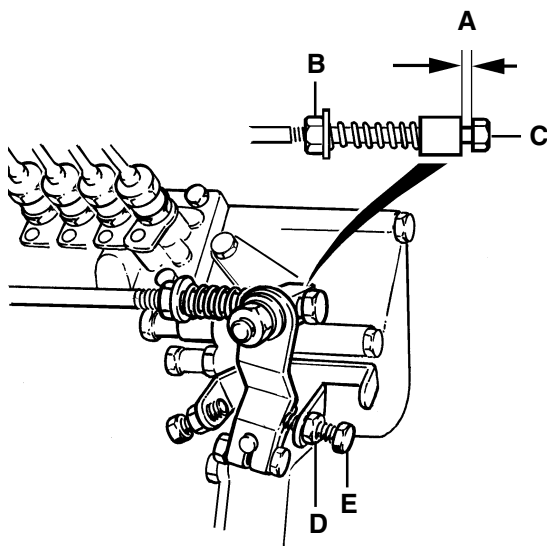

Idling. Adjustment

For engine idling speed: Please refer to the Technical Data chapter. A lower engine speed can cause the engine to stall and a higher engine speeds can cause extra stresses to the drive/reverse when shifting.

Adjust with the engine at operating temperature as follows:

- 1* Set the control lever in the neutral position. Check that gap (A) is approx. 3 mm. Adjustment: Slacken off the locknut (B) and adjust until the correct gap is obtained with screw (C). Tighten the locknut.

*This point does not apply to boats with double control positions.

- 2 Start engine and allow to idle with gear selector in neutral.

⚠ WARNING! Approaching or working on a running engine is dangerous. Watch out for rotating components and hot surfaces.

- 3 Slacken off locknut (D). Adjust engine speed with adjustment screw (E). Tighten the locknut. Repeat step 1.

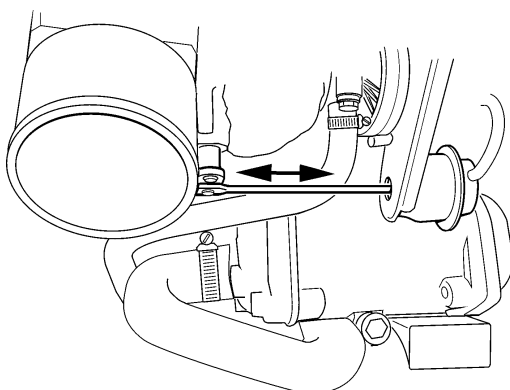

Wastegate (D2-75)

If the engine is not used for a longer period of time there is a risk that the turbocharger boost pressure valve may stick. Check that the shaft turns.

Lubrication system

⚠ IMPORTANT! With a new or reconditioned engine, the oil and oil filters must be changed after 20-50 hours of operation. After that they should be changed every 500 operating hours or at least once a year. Use only the recommended grades of oil: See the chapter "Technical Data".

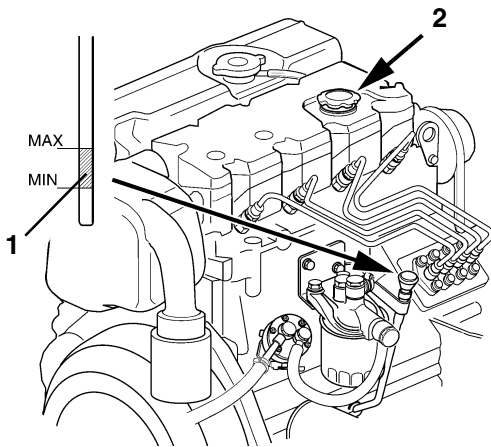

Oil level. Checking and topping up

The oil level should be within the marked area on the dipstick (1). It should be checked every day before the engine is started. Topping up is done through the valve cover (2). Top up oil slowly. Wait a few minutes before checking the oil level again to give the oil time to run down to the oil pan. Then check the level again. Use only the recommended grades of oil: See the chapter "Technical Data".

⚠ IMPORTANT! Do not fill the oil above the MAX level.

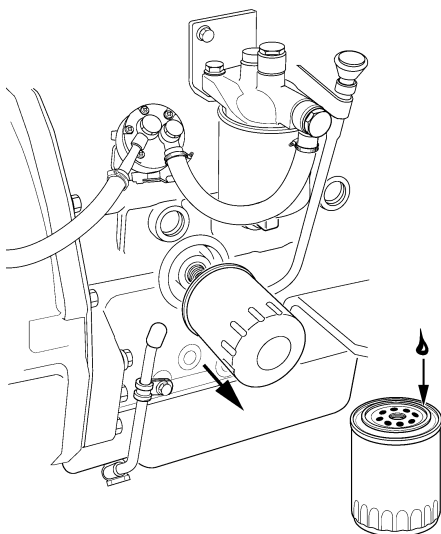
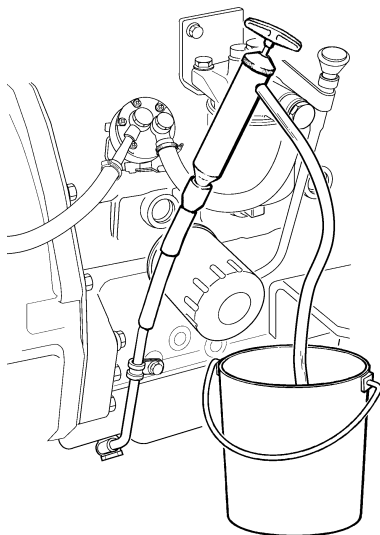

Oil and oil filters. Changing

1. Run the engine to operating temperature so that the oil is easier to suck out. Stop the engine.
2. Suck out the oil using an oil drain pump through oil drain pipe.

⚠ WARNING! Hot oil and hot surfaces can cause burns.

3. Unscrew the old filter. (To avoid oil spills put a plastic bag over the filter before it is unscrewed).
4. Check that the engine mating surface is clean.
5. Moisten the filter rubber gasket with a little oil. Screw on the new filter by hand until it is in contact with the mating surface. And then a further half turn **but no more!**
6. Top up oil to correct level. Start the engine and let it idle. Check that the warning lamp for low oil pressure goes out.
7. Stop the engine. Wait for approx. 10 minutes before checking the oil level. Top up if required. Check that there are no leaks round the oil filter.

NOTE! Collect up the old oil and filter for deposit at a proper disposal site.

Freshwater system

The freshwater system is the engine's internal cooling system. It is a closed system and must always be filled with a coolant that protects it against internal corrosion and freezing when the climate demands.

The circulation pump ensures sufficient circulation in the system. The thermostat will start to open at a certain temperature and will be fully open when the engine has attained normal operating temperature. When the thermostat opens, the warm coolant passes through the heat exchanger where it is cooled by the water in the engine's seawater system.

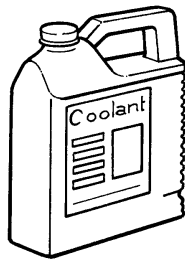

Coolant. General

The freshwater system must be filled with a coolant that protects the engine against internal corrosion and from freezing, if the climate requires it.

⚠ IMPORTANT! Never use water alone.

If the freshwater system is filled with antifreeze mixture it must be changed every other year. If the system is filled with anti-corrosion agent mixture it must be changed every year.

We recommend that a mixture of water and Volvo Penta antifreeze is used all year round, regardless of the climate.

Water quality

To avoid the risk of blocking the cooling system the coolant should be mixed with **clean** water. If there is any doubt over the water quality **distilled water** or **premixed coolant** should be used.

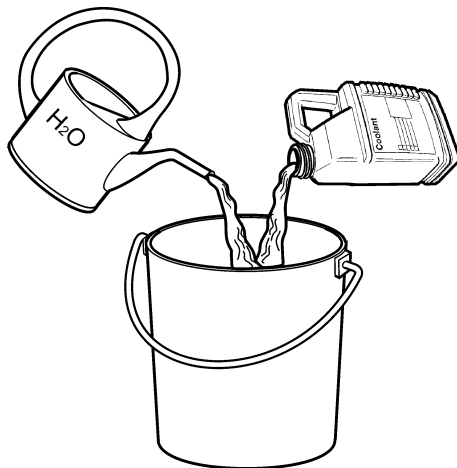

In event of risk of freezing

Use a mixture of 50% Volvo Penta antifreeze (glycol) and 50% pure water. This mixture will protect against freezing to a temperature of approx. -40°C (-40°F) and should be used all year round.

Mix the coolant in a separate container before filling.

⚠ IMPORTANT! There should be at least 40% antifreeze in the system for complete protection against corrosion.

⚠ WARNING! Glycol is harmful to health (dangerous if ingested).

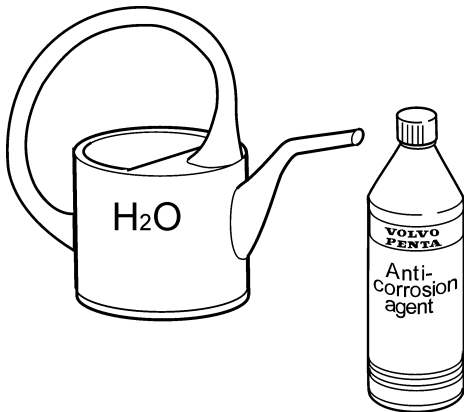

In there is no of risk of freezing

When there is **never** a risk of freezing water **may** be used as coolant with addition of Volvo Penta anti corrosion agent.

Mix according to the instructions on the packaging. Warm up the engine after filling to allow the additive to work as efficiently as possible.

If operating hours exceed 600 hours per annum the coolant anti corrosion must be complemented with ½ liter anti corrosion agent every 600 hours.

⚠ WARNING! Anti-corrosive agents are harmful to health (dangerous if ingested).

⚠ IMPORTANT! Never mix antifreeze (glycol) and anti-corrosive agents. The two combined can produce foam and drastically reduce the coolant's effectiveness.

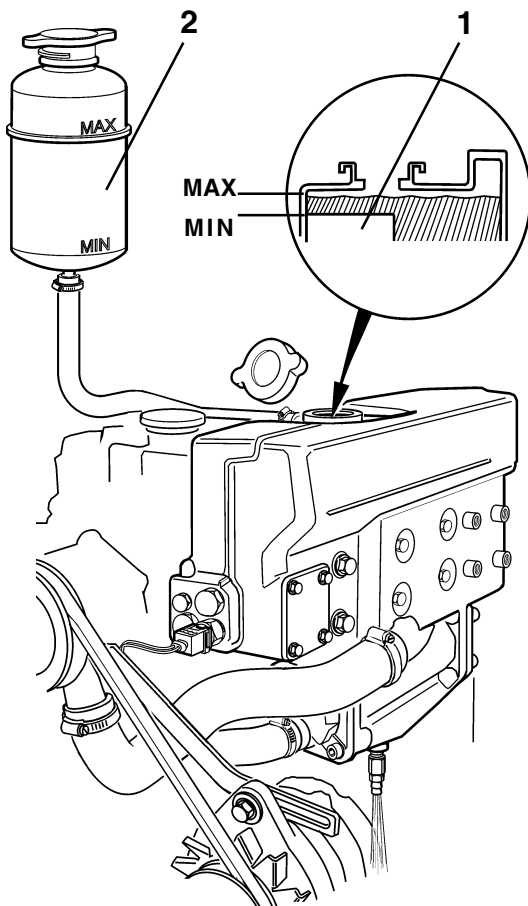

Coolant level. Checking and topping up

⚠ WARNING! Do not open the engine coolant system filler cap when the engine is still hot except in an emergency. Steam or hot coolant may spray out.

Turn the filler cap to the first stop and let any pressure escape from the system before removing the cap. Top up coolant if necessary. The level should lie between the filler neck lower edge and the level spur (1). Reinstall the filler cap.

D2-55:

NOTE! The coolant must not be topped up via the recovery tank (2). Coolant is always to be topped up via the expansion tank or the separate expansion tank if installed. The MAX and MIN mark on the recovery tank does not indicate correct level of coolant! When starting the engine a "thow out" of coolant occur before the thermostat has opened which might show in the recovery tank, this liquid will be sucked back when the engine has cooled.

D2-55 and D2-75:

If a separate expansion tank is installed (optional extra), the coolant level should be between the MAX and MIN levels on the extra expansion tank.

⚠ IMPORTANT! When filling a completely drained system the coolant level must be checked after an hours use because the system is self bleeding. Top up if required.

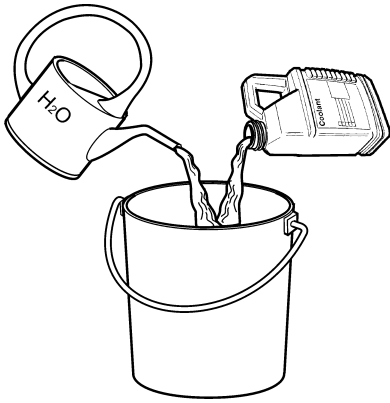

Coolant. Changing

The corrosion-proofing additives become less effective with time and the coolant must be changed. If the freshwater system is filled with antifreeze mixture it must be changed every other year. If the system is filled with anti-corrosion agent mixture it must be changed every year.

Drain off the coolant and clean the heat exchanger as in the following paragraphs. Close the drain tap and the drain plug, and fill up with new coolant.

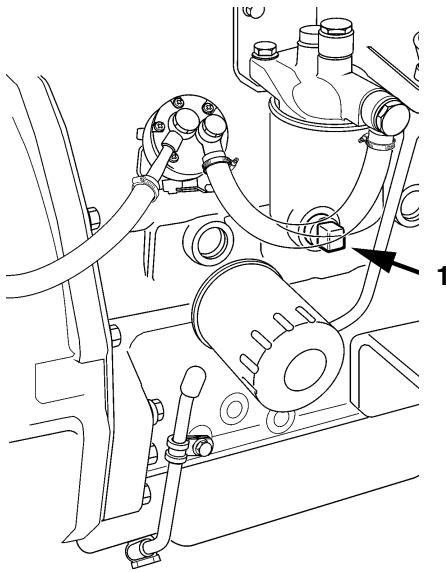

Coolant. Draining

Put a suitable collection vessel underneath the engine drain plug (1) and underneath the heat exchanger drain tap (2). Remove the filler cap on the heat exchanger to let the coolant run out faster. Open the drain plug (1) and the drain tap (2) and drain off all coolant. Before new coolant is put in, clean the heat exchanger as in the following paragraphs.

NOTE! Deposit old coolant at a properly designated disposal site.

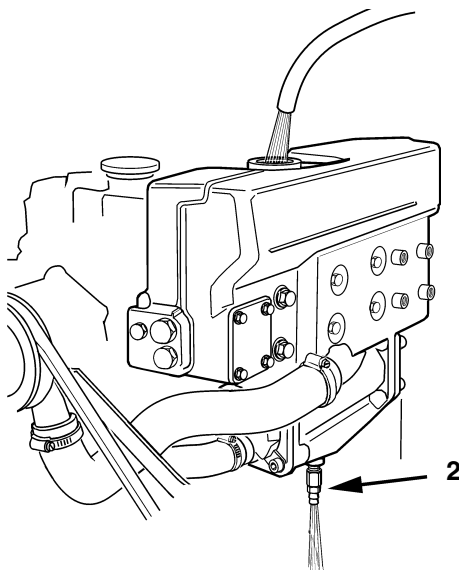

Heat exchanger. Cleaning

Cooling performance is reduced by scaling in the heat exchanger. It should therefore be flushed when the coolant is changed.

1. Drain the coolant as above.
2. Insert a hose into the filling pipe on the heat exchanger. Rinse with fresh water until the water which runs out of the drain tap and the engine block is clean. Let all the water run out.
3. Close the drain tap and the drain plug. Fill up with coolant to the correct level. Put the filler cap back.

Seawater system

The sea water system is the external cooling system of the engine. On engines with a stern drive, the sea water pump sucks in water via the drive, after which the water passes the sea water filter (optional extra) before it is pumped through the heat exchanger. Finally, the water is pumped out into the exhaust elbow pipe, where it is mixed with the exhaust gases.

On engines with a reverse gear, the sea water pump suck in water via the sea water inlet, after which the water passes the sea water filter (optional extra) and the reverse gear oil cooler before it is pumped through the heat exchanger. Finally, the water is pumped out into the exhaust bend, where it is mixed with the exhaust gases.

⚠ WARNING! There is a risk that water will enter while working on the seawater system (if the boat is in the water). Water may flow into the boat if a hose, plug or similar object located below the waterline is removed. So always close the seawater cock. If the boat does not have a seawater cock, the flow of water must be stopped in a safe manner. The boat must be brought up on land if this is not possible.

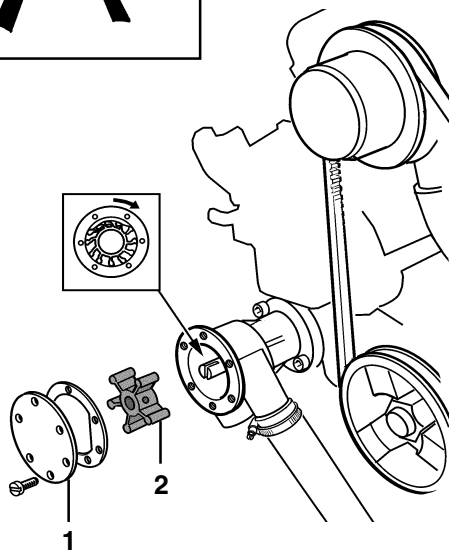
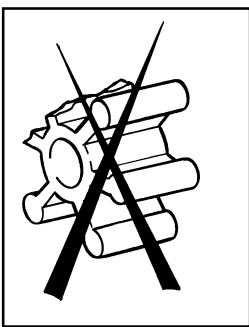

Impeller. Checking/Replacing

⚠ WARNING! Risk for water penetration. Close the sea cock.

Close the sea cock. Remove cover (1) on the seawater pump. Remove impeller (2). If there are cracks or other defects the impeller must be replaced. Lubricate the pump housing and the inside of the cover with a little waterproof grease **for rubber**. Reinstall the impeller using a clockwise rotating movement. Install the cover together with a new gasket. Open the sea cock.

⚠ IMPORTANT! Always carry a spare impeller on board.

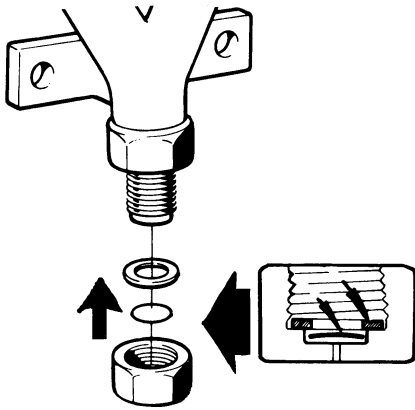

Vacuum valve. Cleaning

Some engines have a vacuum valve installed in the seawater piping.

⚠ WARNING! Risk for water penetration. Close the sea cock.

Close the sea cock. Disassemble the valve. Unscrew the hexagonal cover. In the cover there is a membrane and a gasket. Clean all the parts. Turn the cover upside down. Install the membrane first and then the gasket. Turn the valve housing upside down as well. Screw the cover into position, but not too hard (0.2 kpm), or the valve may stop working.

Seawater filter. Cleaning

The seawater filter is an accessory. Screw off cover (1) and remove seal plate (2). Lift out and clean the insert (3).

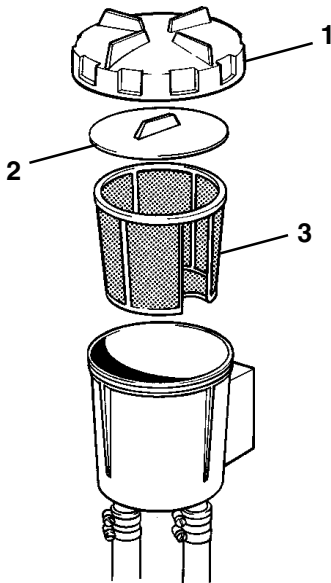

⚠ IMPORTANT! If the boat is used in water that has a lot of contaminants, seaweed etc. the filter must be checked more frequently than indicated in the maintenance schedule. Otherwise there is a risk the filter will clog and the engine will overheat.

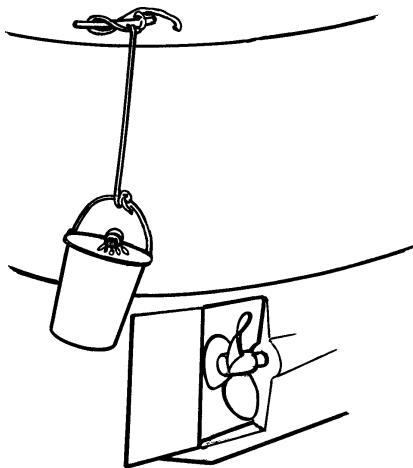
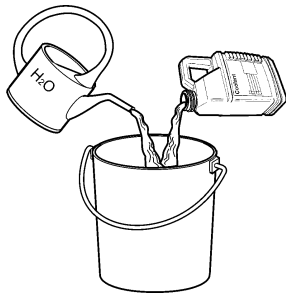
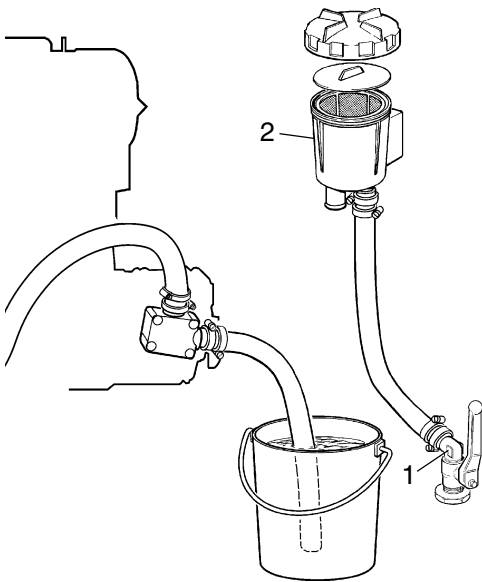

Seawater system. Flush cleaning and corrosion inhibition

When laying up during winter (or out of season), the seawater system must be flushed clean of all deposits and salt crystals. It must also be treated to protect against internal corrosion.

⚠ WARNING! Risk of water penetration. This work must be carried out with the boat on dry land.

Approaching or working on a running engine is dangerous. Watch out for rotating components and hot surfaces.

Glycol is harmful to health (dangerous if ingested). Collect used and drained glycol and take it to a proper disposal site.

1. Open the seawater cock (1).
2. Disconnect the hose at the seawater cock (1) or on the outlet side of the sea water filter (2) (if the engine is equipped with such a filter).

3. Place the free end of the hose in a bucket of fresh water. Fill the system.

⚠ IMPORTANT! The impeller will be damaged if it runs dry.

4. Check that there is nobody close to the propeller and there is nothing that will get splashed behind the exhaust outlet.
5. Set the control lever to neutral. Start the engine. Let the engine run at fast idle for a few minutes. Stop the engine.
6. Fill the bucket with an anti-freeze mixture (50% Volvo Penta glycol and 50% fresh water). Collect the mixture from the system in a suitable container.
7. Start the engine and let it idle. Stop the engine just before the mixture is finished.
Repeat as necessary until the entire system has been flushed with the mixture.
8. Reconnect the hose.

This mixture prevents corrosion and protects against freezing. It must be left in the seawater system throughout the laying-up period. Drain the mixture just before the boat is launched.

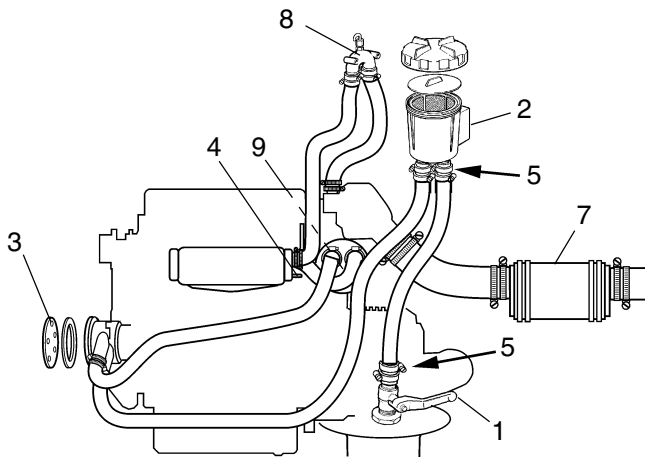

MS25S / 150S

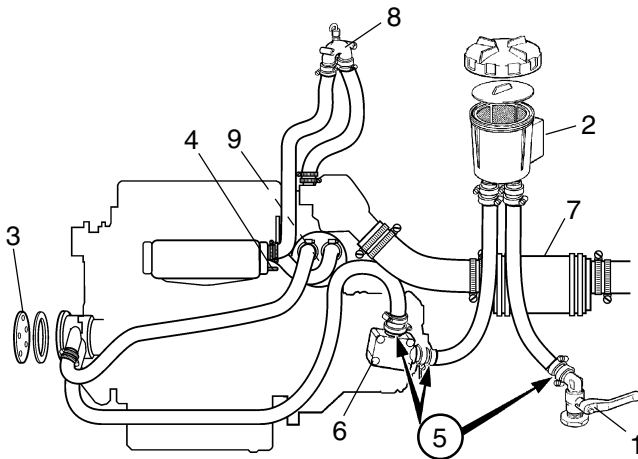

MS25 / HS25

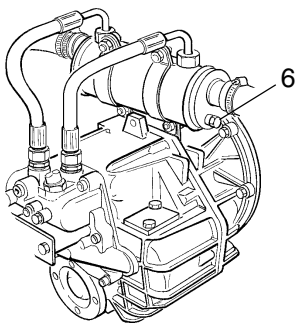

HS25

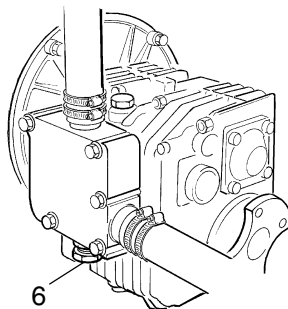

MS25

Seawater system. Draining

If it is not possible to keep the engine compartment free of frost, the seawater system must be drained to prevent freezing damage.

Note that all the seawater must be drained. The type of drainage must be adapted to the way in which the engine is installed and any additional equipment that is connected, for example sea water filter (2), vacuum valve (8), silencer (7) etc.

⚠ WARNING! Risk of water penetration. Close the sea cock before starting work.

⚠ IMPORTANT! If the boat is laid-up for winter or the off season, the seawater system must be instead flushed clean and protect against corrosion according to the instructions in the previous section.

Draining:

1. Close the seawater cock (1).
2. Remove the cover and sealing plate on the sea water filter (2).
3. Remove the cover (3) from the seawater pump. Let the water run out.
4. Open the drain cock (4) on the rear end of the heat exchanger and drain the water off.

D2-75:

Open the drain cock on the charge air cooler (9) draining the water.

5. Disconnect the hoses where indicated by the arrows (5). Drain the hoses.
6. Open the drain plug (6) on the reverse gear oil cooler and drain the water off. Close the drain plug.
7. Drain the silencer (7), the exhaust system and any other additional equipment connected to the seawater and exhaust systems.
8. Reinstall all hoses, the cover on the seawater pump and the cover and sealing plate on the seawater filter. Close the drain cock on the heat exchanger.

D2-75:

Close the draincock on the charge air cooler.

9. Opened the seawater cock the next time the boat is used.

⚠ WARNING! Check that there is no leakage in the seawater system.

Fuel system

All work on the engine injection pump or injectors must be carried out at an authorized workshop. Use only the recommended grade of fuel: See the chapter "Technical Data".

⚠ WARNING! Fire risk. When carrying out work on the fuel system make sure the engine is cold. A fuel spill onto a hot surface or an electrical component can cause a fire. Store fuel soaked rags and other flammable material in fireproof conditions.

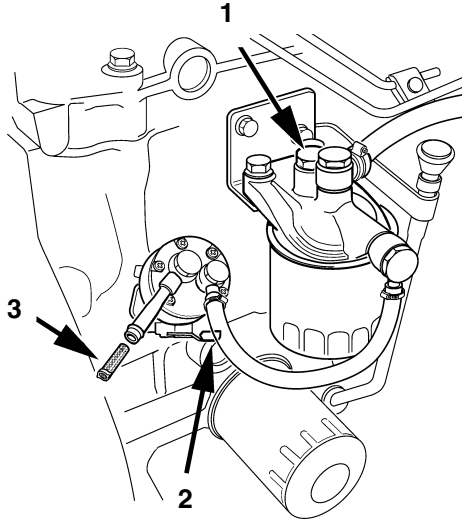

D2-55

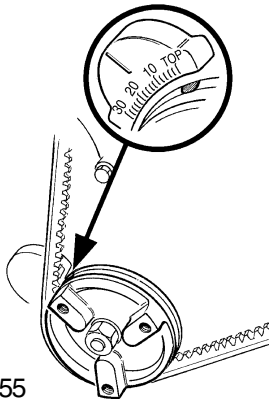

D2-55

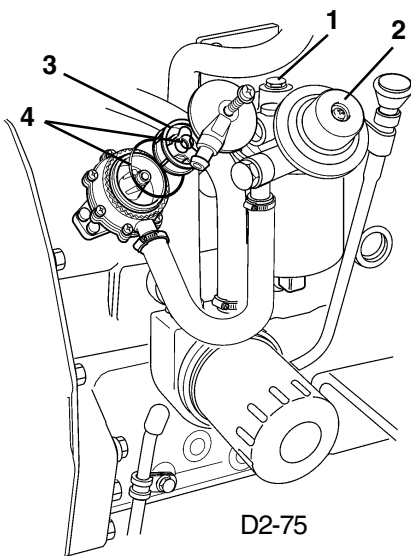

D2-75

Venting the fuel system

The fuel system must be vented after fuel filters have been replaced or after refilling the fuel tank after it has been run dry.

1. Open vent screw (1) on the filter mounting approx. three turns. Avoid fuel spillage. Use rags around the venting point.
2. Pump the fuel using hand pump (2) until there are no more air bubbles visible in the fuel. Continue pumping and at the same time tighten the venting screw.

D2-55: If the pump output is low, turn the engine so that the marking on the pulley is at "TOP" (see the illustration). If the pump output is still low, turn the engine one more revolution to "TOP".

There is a strainer (3) in the intake manifold for the pump. The strainer does not normally need to be cleaned since the engine should be installed with a fuel pre-filter. If there is no fuel pre-filter installed, low output may be due to a blocked strainer.

D2-75: If any of the two o-rings (4) are damaged they need to be replaced.

3. Start the engine and check for leaks.

⚠ WARNING! Approaching or working on a running engine is dangerous. Watch out for rotating components and hot surfaces.

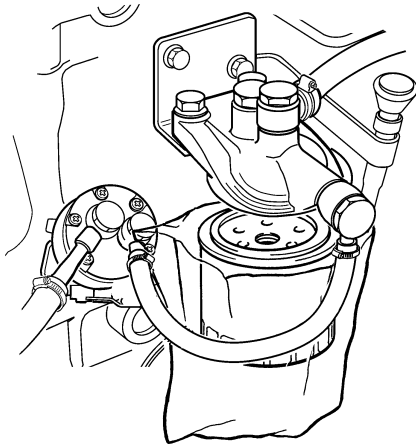

Fuel filter. Changing

Clean the filter mounting. To avoid fuel spills put a plastic bag over the filter before it is unscrewed. Unscrew the filter. Moisten the filter rubber gasket with a little oil. Screw on the new filter by hand until it is in contact with the mating surface. And then a further half turn **but no more!** Vent fuel system. **Deposit the old filter at a properly designated disposal site.**

Start the engine and check for leaks.

⚠ WARNING! Approaching or working on a running engine is dangerous. Watch out for rotating components and hot surfaces.

Fuel pre-filter. Draining and replacing filter insert

Draining

The fuel pre-filter is an optional extra.

Position a container under the fuel filter. Drain off water and contaminants using the cock/plug at the bottom of the filter bowl.

⚠ IMPORTANT! Wait a few hours after the engine has been turned off before draining the filter.

Replacing filter insert

Close fuel cock at the fuel tank. Position a container under the fuel filter.

Remove the filter bowl by undoing screw (1). Empty and clean the filter bowl. Replace insert and reinstall the bowl. Open fuel cock. Vent fuel system. **Deposit the old filter insert at a properly designated disposal site.**

Start the engine and check for leaks.

⚠ WARNING! Approaching or working on a running engine is dangerous. Watch out for rotating components and hot surfaces.

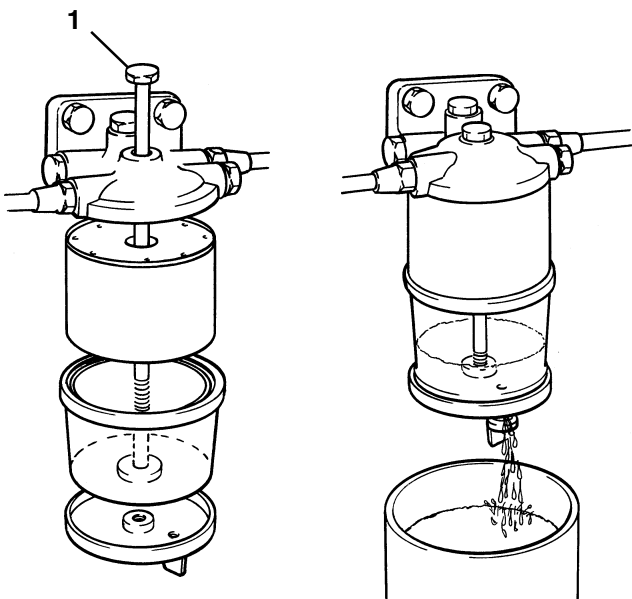

Electrical system

⚠ WARNING! Always stop the engine and break the current using the main switches before working on the electrical system. Isolate shore current to the engine block heater, battery charger, or accessories mounted on the engine.

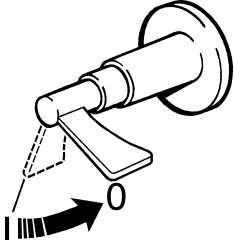

Main switch

The main switch must never be turned off before the engine has stopped. If the circuit between the generator and the battery is cut off when the engine is running the generator can be seriously damaged. For the same reason charging circuits must never be switched over while the engine is running.

⚠ IMPORTANT! Never break the circuit with the main switches while the engine is running.



Electrical connections

Also check that all electrical connections are dry and free of oxidation and that there are no loose connections. If necessary, spray these connections with a water-repellent spray (Volvo Penta Universal oil).

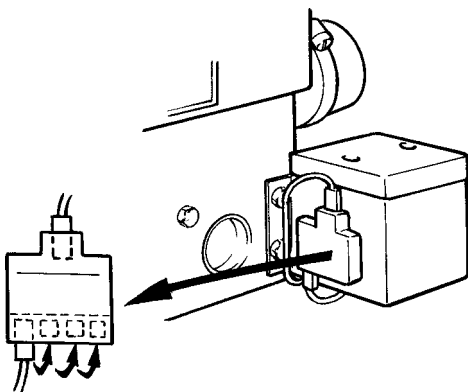

Fuses

The engine has a fuse holder with four 15 A fuses. This is located on the relay box to the left of the engine. One fuse protects the system and cuts power in the event of an overload, the others are spares.

If a fuse blows the system can be reconnected by moving the cable to the next fuse. Always investigate the cause of an overload before resetting the fuse!

⚠ IMPORTANT! Make sure that you always have spare fuses on board.



Battery. Maintenance

⚠ WARNING! Risk of fire and explosion. Never allow an open flame or electric sparks near the battery or batteries.

⚠ WARNING! Never mix up battery positive and negative terminals. This may cause sparks and an explosion.

⚠ WARNING! The battery electrolyte contains extremely corrosive sulfuric acid. Protect your skin and clothes when charging or handling batteries. Always use protective goggles and gloves. If battery electrolyte comes into contact with unprotected skin wash off immediately using plenty of water and soap. If battery acid comes into contact with the eyes, flush immediately with plenty of water and obtain medical assistance without delay.

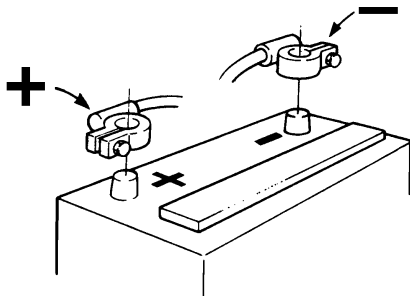

Connecting and disconnecting

First connect the red battery lead + to the battery + terminal. Then connect the black battery lead - to the battery - terminal.

When disconnecting the battery, disconnect the -lead (black) first and then the + lead (red).

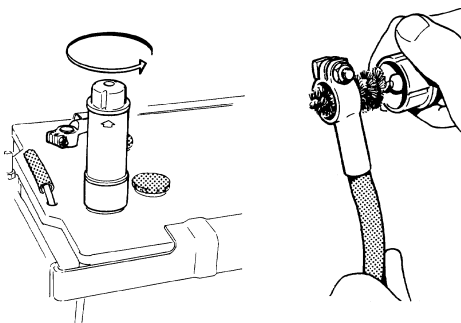

Cleaning

Keep batteries dry and clean. Oxidation or dirt on the battery and battery terminals can cause short-circuits, voltage drop and discharge especially in damp weather. Clean the battery terminals and leads to remove oxidation using a brass brush. Tighten the cable terminals well and grease them with terminal grease or petroleum jelly.

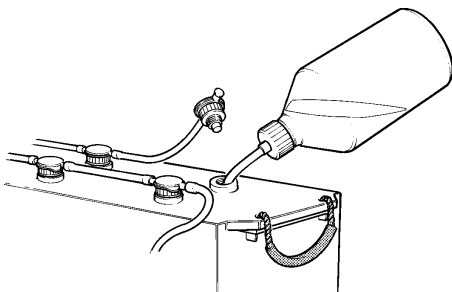

Topping up

The electrolyte should be 5 - 10 mm over the plates in the battery. Top up using **distilled water** if necessary. Charge the battery after topping up for at least 30 minutes by running the engine at fast idle. **NOTE!** Certain maintenance-free batteries have special instructions which must be followed.

Battery. Charging

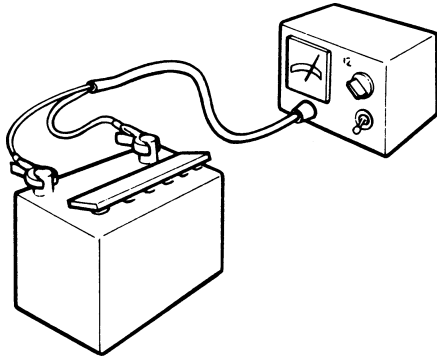

⚠ WARNING! Danger of explosion! The batteries give off hydrogen gas during charging which when mixed with air can form an explosive gas - oxyhydrogen. A short-circuit, naked flame or spark can cause a large explosion. Ensure that the ventilation is good.

⚠ WARNING! The battery electrolyte contains extremely corrosive sulfuric acid. Protect your skin and clothes when charging or handling batteries. Always use protective goggles and gloves. If battery electrolyte comes into contact with unprotected skin wash off immediately using plenty of water and soap. If battery acid comes into contact with the eyes, flush immediately with plenty of water and obtain medical assistance without delay.

If the battery has discharged it must be charged. If the boat has not been used for some time charge the battery and then trickle charge it (see manufacturer's recommendations). A poorly charged battery will be damaged and may burst in cold weather.

⚠ IMPORTANT! Follow the instructions supplied with the battery charger carefully. To avoid electrolytic corrosion when an external charger is connected, always disconnect the battery leads before connecting the charger.

When charging, unscrew filler plugs but leave them in their holes. Ventilation should be good, particularly if the batteries are being charged in an enclosed area.

⚠ WARNING! Always switch off the charging circuit **before** removing the battery charger connectors. Never mix up battery positive and negative terminals. This may cause sparks and an explosion.

Special instructions apply when **boost charging** the batteries. Avoid boost charging the batteries as it will shorten their service life.

Electrical installations

Leakage current from the electrical system can be caused by incorrect installation of electrical equipment. Leakage current can knock out the galvanic protection of components such as the drive, propeller, propeller shaft, rudder stock and keel and cause damage by electrolytic corrosion.

⚠ IMPORTANT! Work on the boat's low tension circuit should only be carried out by qualified or experienced persons. Installation or work on the shore power equipment **must only** be carried out by electricians authorized to work with high-voltage installations.

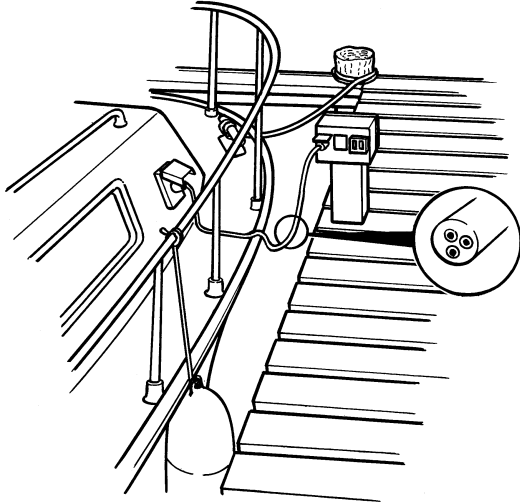

The following should always be observed:

1. If shore power is connected, the protector ground should be ashore, never in the boat. Shore power should always have a ground fault circuit breaker.

Shore power units (transformer, rectifier, battery chargers etc.) must be intended for marine usage **and the high tension circuit must be galvanically separated from the low tension circuit.**

2. Route and clamp electric cables so that they will not be exposed to rubbing, damp or bilge water in the keelson.
3. The S-drive is electrically isolated (A) from the engine and must never be used as a ground.

⚠ IMPORTANT! The S-drive must never be used as a ground or be electrically connected to other equipment such as the radio, navigational equipment, the rudder, bathing steps etc.

Protective grounds for the radio, navigational equipment, rudder, bathing steps or other equipment with separate ground leads must be connected to a common ground terminal (B).

4. There must be a main switch (C) connected to the starter battery positive (+) terminal. The main switch should cut off power to all power consuming equipment and should be switched off when the boat is not in use.

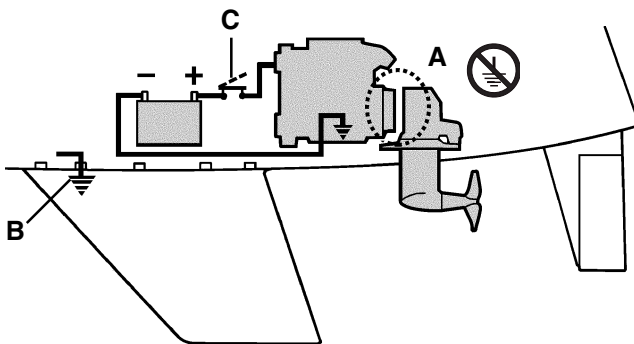

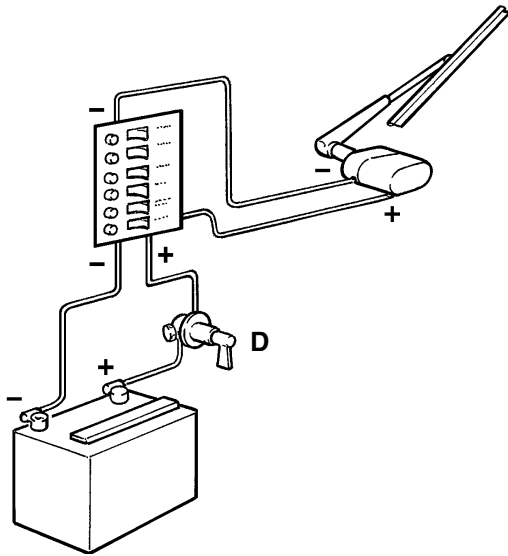

5. If an auxiliary battery is in use, a main switch (D) should be connected between its + terminal and the fuse block. The main switch for the auxiliary battery must cut off all power consuming equipment connected to that battery and be turned off when power is no longer needed.

All equipment connected to the auxiliary battery should have separate switches.

To simultaneously charge two independent battery circuits, fit a Volvo Penta charge distributor (accessory) to the regular generator.

Electrical components diagram

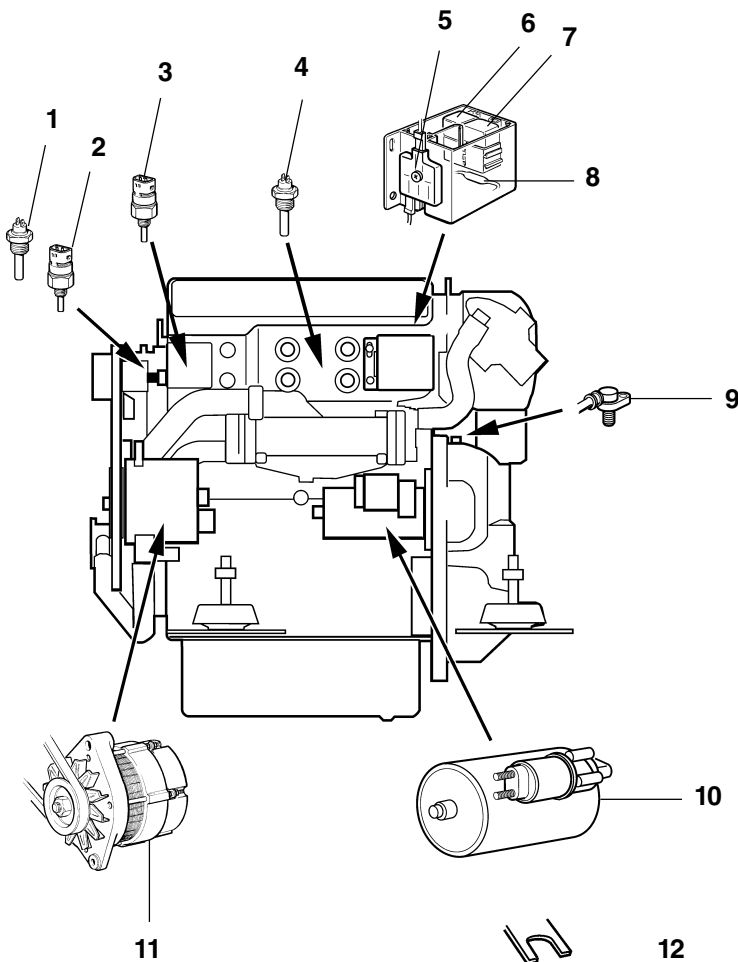

1. Engine coolant temperature sensor D2-55 (optional extra)
2. Coolant temperature switch D2-55
3. Engine coolant temperature sensor D2-75
4. Coolant temperature switch D2-75
5. Fuses
6. Starter relay
7. Glow plug relay
8. Ballast resistor
9. Engine speed sensor
10. Starter motor
11. Generator
12. Glow plugs, 4 st
13. Oil pressure sensor D2-55 (optional extra)
14. Oil pressure switch D2-55
15. Combined oil pressure switch/sensor D2-75

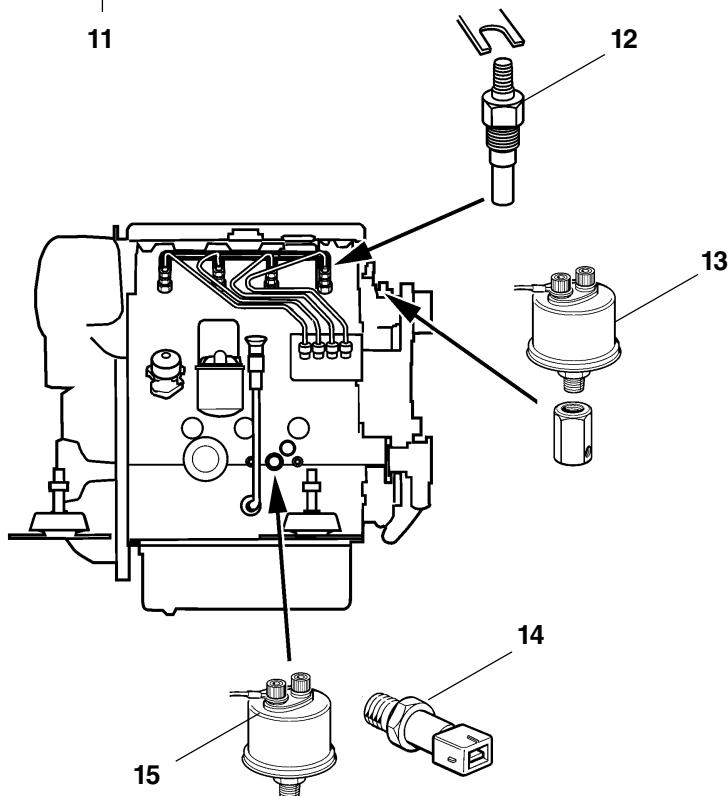

S drive and reverse gear

The S drive and in certain cases the propeller (reverse gear) is equipped with a sacrificial anode which prevents galvanic corrosion. Faulty electrical installation can also cause the break down of the galvanic protection. Damage due to electrolytic corrosion occurs rapidly and is often extensive. For further information see the chapter: "Electrical system"

⚠ IMPORTANT! Improperly applied paint or the wrong type of paint on the keel can put the corrosion protection system out of action. For further information on painting see the chapter: Laying up/Launching

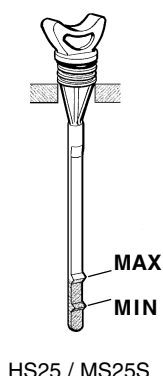
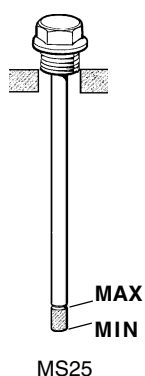

Oil level. Check

Remove the dipstick by turning counter-clockwise. Wipe the dipstick and reinsert it in the drive / reverse gear **without screwing it in**. Remove the dipstick and check the oil level. The correct oil level is between the MAX and MIN markings.

Top up the oil as required using the dip stick tube. For oil quality and capacity: See the chapter "Technical Data".

⚠ IMPORTANT! Do not overfill under any circumstances. The oil level must always be within the recommended level.

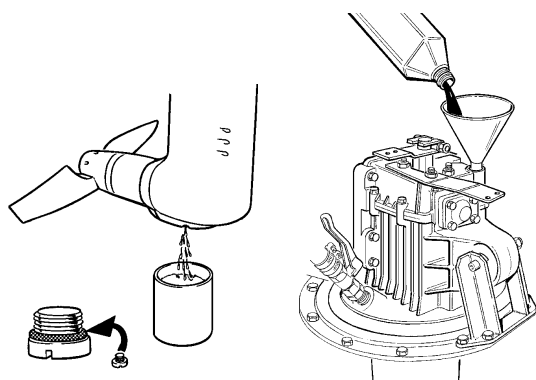

Oil change. S-drive

Remove the oil dipstick. Remove the plug on the propeller gear housing and let the oil run out. Check that the plug o-ring is intact. Replace if necessary. Install the plug and o-ring. Top up oil to correct level. For oil quality and capacity: See the chapter "Technical Data".

⚠ IMPORTANT! If oil is colored gray then water has entered the drive. Please contact an authorised Volvo Penta workshop.

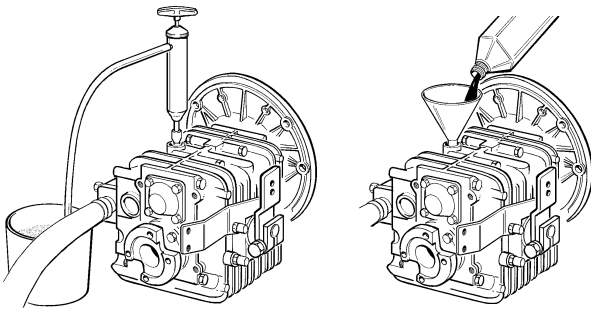

Oil change. MS25

Remove the dipstick. Suck up oil using an oil pump through the hole for the dipstick. Measure out the correct amount of oil and fill up through the hole for the oil dipstick. For oil quality and capacity: See the chapter "Technical Data".

⚠ IMPORTANT! Never overfill reverse gear. The oil level should always lie at the recommended level.

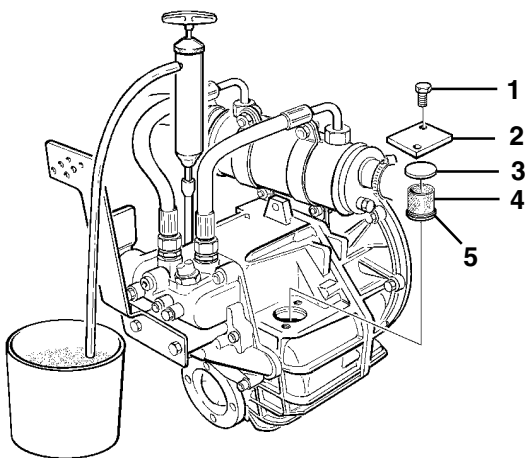

Oil change and filter cleaning. HS25

1. Clean around the cover (2) so that there is no risk of the dirt falling into the filter housing.
2. Undo the screws (1). Remove the cover (2) and gasket (3).
3. Carefully remove the filter (4). Clean the filter in kerosene (leave the gasket (5) in place). Clean the filter housing.
4. Suck up oil using an oil pump through the hole for the dipstick.
5. Measure out the correct amount of oil and fill up through the hole for the oil dipstick or filter housing. For oil quality and capacity: See the chapter "Technical Data".

⚠ IMPORTANT! Never overfill reverse gear.

6. Reinstall the filter (4) with gasket (5) in the filter housing. Check that the filter bottoms correctly.

⚠ IMPORTANT! If the filter does not sit flat there is a risk of breaking it when the cover (2) is installed.

7. Center the gasket (3) above the filter. Install the cover.
8. Move the control lever to the neutral position. Start engine and run at 1500 rpm for a few minutes so the reverse gear oil cooler is filled with oil.
9. Stop engine and check oil level. Top up if required.

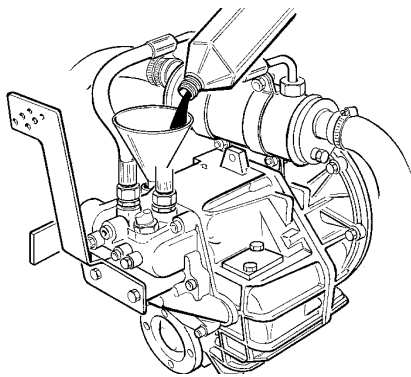

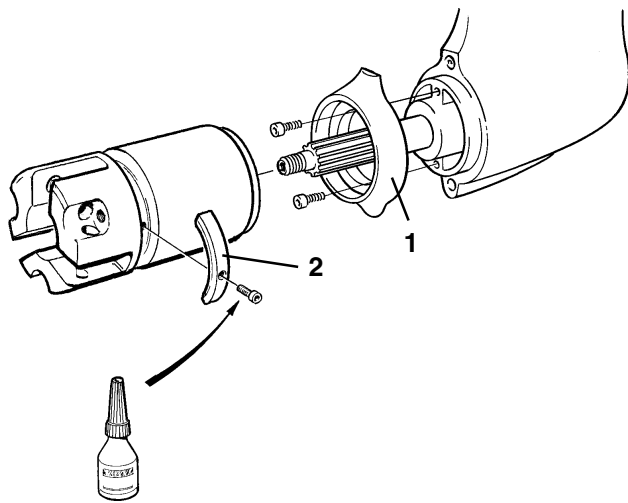

Corrosion protection. Check

Check the sacrificial anode (1) on the drive and the three sacrificial anodes (2) on the propeller. Replace with a new anode if 50% of the material has perished or at least once per season.

⚠ IMPORTANT! Use zinc sacrificial anodes for salt water and magnesium anodes for freshwater.

Remedy any paintwork damage on the drive according to the instruction in the chapter: Laying up / Launching.

Replacing sacrificial anodes

1. Remove the propeller (see the next section).
2. Remove the sacrificial anodes. Thoroughly scrape clean the mating surfaces on the drive and propeller.
3. Apply thread sealant to the screws for the sacrificial anodes on the propeller.
4. Install the new sacrificial anodes. Tighten the anodes so that there is a good metal contact.
5. Reinstall the propeller.

The sacrificial anodes oxidise when they come into contact with air. This reduces the galvanic protection. There may even be oxidation on the surface of a completely new anode. **Always clean the sacrificial anodes before launching the boat.**

⚠ IMPORTANT! Use emery paper. Do not steel tools when cleaning, as these may damage the galvanic protection.

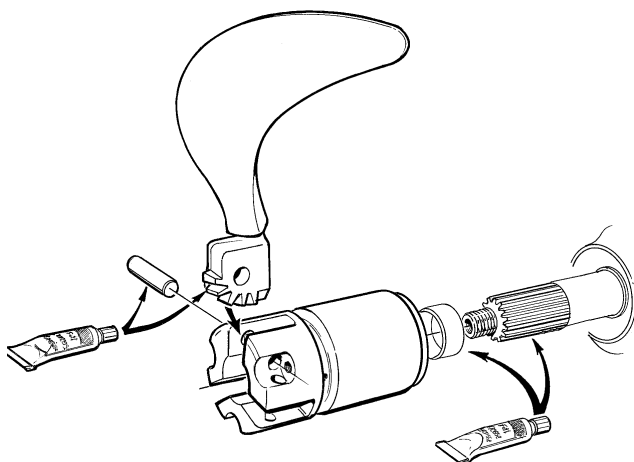

Folding propeller. Cleaning

The propeller must be cleaned and lubricated once a year. Remove the propeller and clean all components thoroughly. Apply waterproof grease to the propeller blade teeth and bearing surfaces so that the propeller folds easily. Also apply waterproof grease to the studs, spacing sleeve (drive), propeller shaft and hub.

⚠ WARNING! Prevent accidental starting. Remove the ignition key and turn off the power at the main switch before working on the propeller.

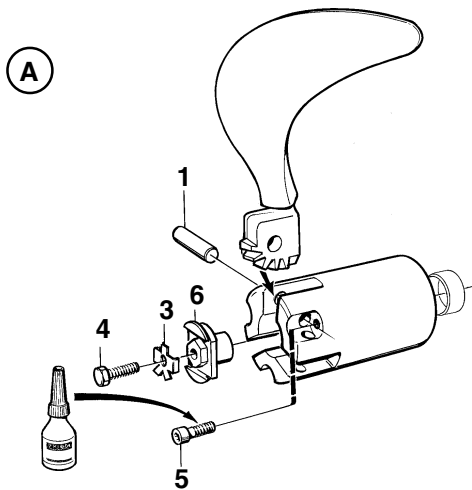

Removing

1. Set the control lever in the "Ahead" position.
2. Remove the propeller blade by first undoing the locking screws (5) completely and then pressing out the shaft studs (1).
3. **Drive:** Bend down the tabs of the tab washer (3) and remove the locking screw (4), tab washer and nut (6).
- Reverse gear:** Remove the nut (7), washer (8) and then the locking screws (9).
4. Pull off the propeller hub and the spacing sleeve (drive). Clean and lubricate as described.

Installing

1. Reinstall the spacing sleeve (drive) and the propeller hub on the shaft.
2. **Drive:** Install the nut (6). Place a propeller blade on the hub and place a wooden block between the propeller blade and the underwater hull. Tighten locknut to 70 Nm.
Reverse gear: Install the washer (8) and tighten the nut (7) to 220 Nm. Apply thread sealant to the locking screws (9). After the locking screws have been tightened apply thread sealant to the screw heads as well.
3. **Drive:** Locate the tab washer (3) on the nut. Install and tighten the locking screw (4) to 20 Nm and bend one of the tab washer tabs to the screw head.
⚠ IMPORTANT! The tab washer (3) must be replaced if necessary. Use only Volvo Penta original locking screws (4).
4. Install one propeller blade in the propeller hub and push in the stud (1) in such a position so the groove in the stud is exactly centered in the hole for the locking screw (5). Apply thread sealant to the locking screw and tighten to 10 Nm.
5. Install the other blades in the same way. Check the blades are at the same angle to the propeller shaft and that they move easily.

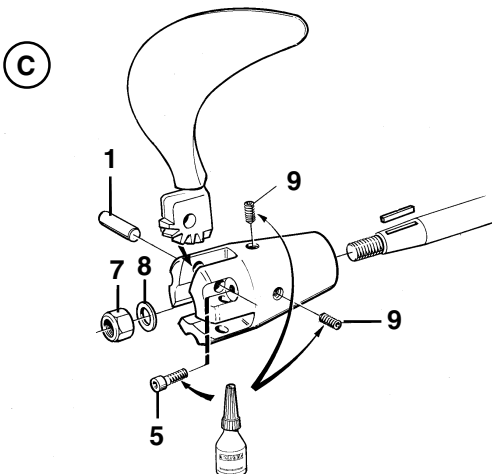
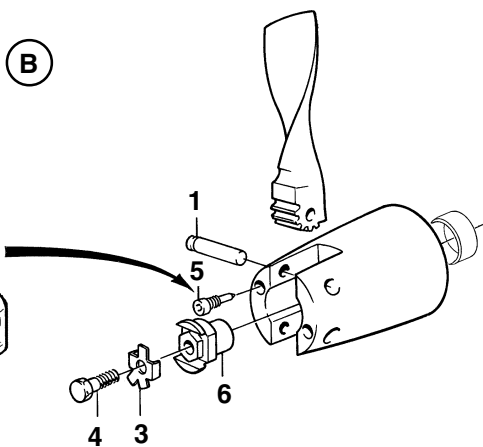

- A = 3-blade folding propeller (drive)
 B = 2-blade folding propeller (drive)
 C = 3-blade folding propeller (reverse)

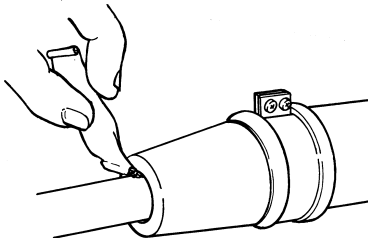
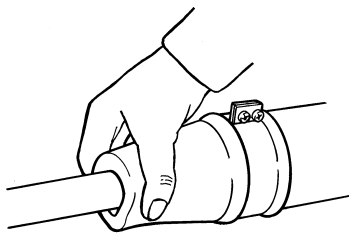

Propeller shaft seal. Reverse gear

If the boat has a Volvo Penta shaft the shaft seal must be vented and lubricated directly after launching.

Vent the bushing by pressing it together while pressing down on the shaft until water appears. Then press in approx. 1 cc **water repellent grease** into the seal.

⚠ IMPORTANT! The seal must be replaced every 500 running hours or every 5th year.

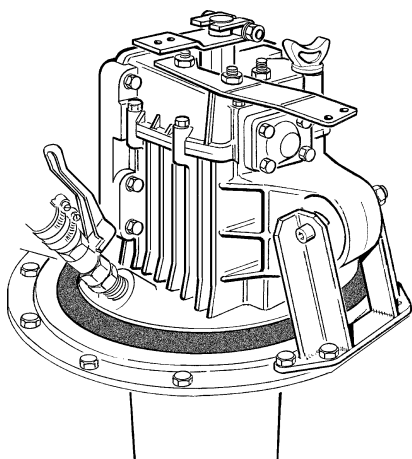

Rubber seal. S-drive

Check the rubber seal between the drive and the hull regularly for cracks and wear.

⚠ WARNING! The seal must be changed every seven years or earlier if it is defective. This work should be carried out by an authorized workshop.

Laying up and launching

Before taking the boat out of the water for winter/out-of-season storage have an authorized Volvo Penta workshop inspect the engine and other equipment.

Inhibition should be carried out to ensure that the engine and transmission are not damaged while out of commission during the winter/off-season. It is important this is done properly and that nothing is forgotten. We have therefore provided a checklist covering the most important points.

⚠ WARNING! Read the chapter on Maintenance carefully before starting work. It contains instructions on how to carry out the work safely and correctly.

Inhibiting

The following are best carried out with the boat in the water:

- Change engine oil and replace oil filter.
- Change oil in the reverse gear.
- Replace fuel filter. Replace fuel pre-filter if installed.
- Run engine to normal operating temperature.
- Take the boat out of the water:

The following should be carried out with the boat out of the water:

- Clean the hull and drive directly after taking up the boat (before it dries).

⚠ IMPORTANT! Be careful when cleaning with a high pressure water spray. Never direct the water jet at the propeller shaft seal, grommets etc.

- Change oil in the drive.
- Clean the vacuum valve and seawater filter (accessory).
- Clean and inhibit the seawater system.
- Remove the impeller from the seawater pump. Store the impeller in a sealed plastic bag in a cool place.
- Check the condition of the engine coolant anti-freeze. Top up if required.

⚠ IMPORTANT! An anti-corrosion mixture in the engine coolant system provides no protection against freezing. If there is any possibility the engine will be subjected to freezing temperatures then the system must be drained.

- Drain any water and contaminants from the fuel tank. Fill the tank completely with fuel to avoid condensation.

- Clean the outside of the engine. Do not use a high pressure spray to clean the engine. Touch up any damaged areas of paintwork with Volvo Penta original paint.
- Check all control cables and treat with rust inhibitor.
- Repair any damaged areas of paintwork with Volvo Penta original paint. NOTE! Read the special instructions on painting the drive under the heading: Painting the drive and underwater hull
- Disconnect battery leads. Clean and charge the batteries. NOTE! A poorly charged battery may burst as a result of freezing.
- Spray electrical system components with moisture repellent spray.
- Remove the propeller for storage. Grease the propeller shaft using water repellent grease. Disassemble folding propellers, clean and grease.
- Check the rubber seal between the drive and hull carefully.

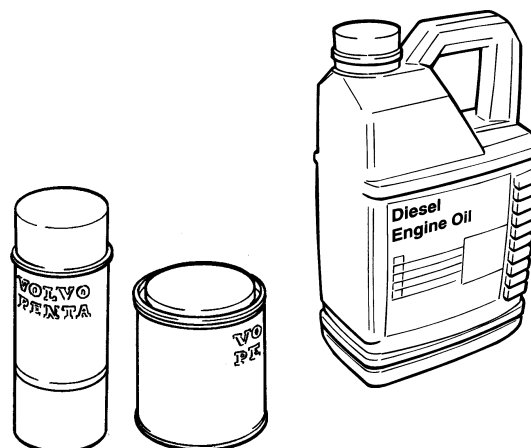

Bringing out of storage

- Check oil level in the engine and drive/reverse gear. Top up if necessary. If there is inhibiting oil in the system drain and fill with new oil, change oil filter. For correct oil grade: See the chapter "Technical Data".
 - Drain the antifreeze from the seawater system.
 - Install the impeller in the seawater pump (replace if the old one looks worn).
 - Close/tighten drain cocks/plugs.
 - Check drive belts.
 - Check the condition of rubber hoses and tighten hose clamps.
 - Check engine coolant level and antifreeze protection. Top up if necessary.
 - Connect the fully charged batteries.
 - Paint the drive and hull: See next page.
 - Check the sacrificial anode on the drive. If there is less than 50% of the anode left it must be replaced. Clean with emery cloth just before the boat is launched.
- ⚠ IMPORTANT!** Do not use a wire brush or other steel tools when cleaning, as these may damage the galvanic protection.
- Reinstall the propeller.
 - Launch the boat. Check for leaks.
 - Vent and lubricate the propeller shaft seal (reverse gear).
 - Start the engine. Check that there are no fuel, engine coolant or exhaust gas leaks and that all control functions are operating.

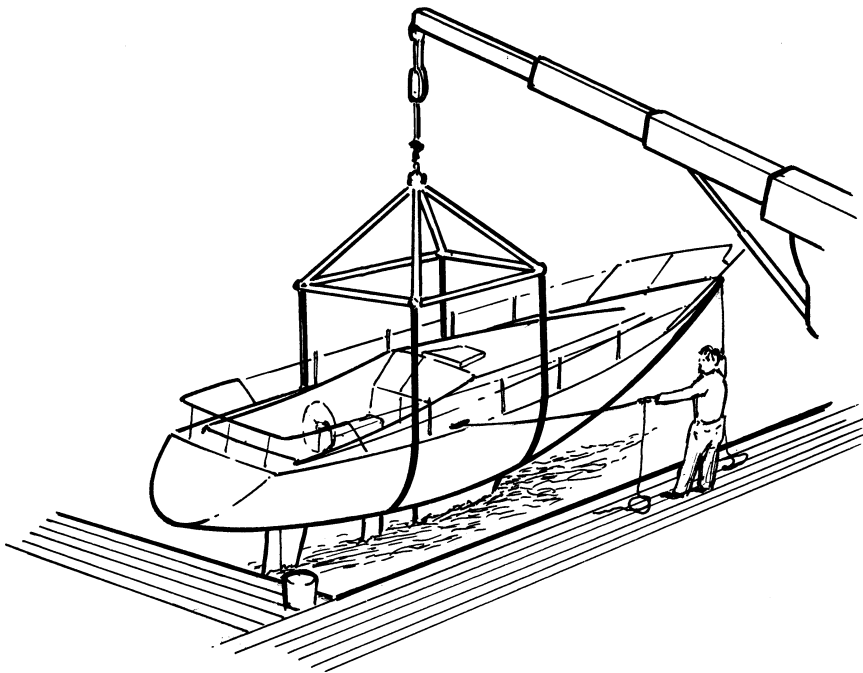

Painting the drive and underwater hull

General

Most countries have introduced legislation controlling the use of anti-fouling agents. In some cases these agents are completely forbidden for use on leisure craft. **In these cases ask your Volvo Penta dealer for advice about alternative methods.**

⚠ IMPORTANT! Find out what regulations apply to the use of anti-fouling agents.

Drive

The paintwork is part of the drive's anti-corrosion protection and it is therefore important that any paintwork damage is remedied.

Sand down metal surfaces lightly using a 120 grade paper and a finer grade for painted surfaces. Wash off using thinners or similar. Any pores in the surface should be filled and sanded down. Paint using Volvo Penta original primer and topcoat. Let the paint dry.

The drive should be painted with Volvo Penta anti-fouling to prevent fouling. Apply according to the instructions on the packaging.

⚠ IMPORTANT! The sacrificial anodes on the drive and propeller must not be painted.

Underwater hull

Anti fouling agent containing copper oxide can increase the risk of galvanic corrosion and therefore should never be used.

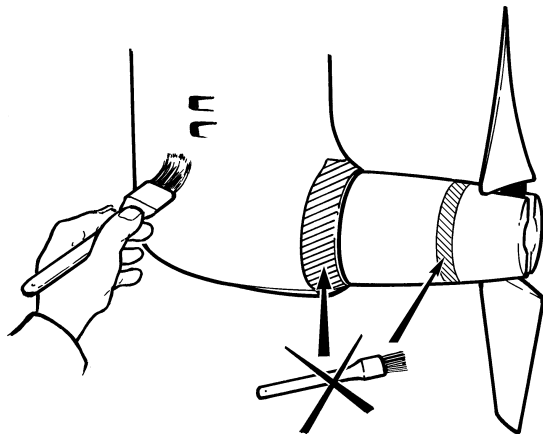

Fault-tracing

A number of symptoms and possible reasons for engine problems are described in the table below. In case of faults or mishaps which you cannot solve, always contact the Volvo Penta dealership.

⚠ WARNING! Read the safety precautions for maintenance and service in the chapter: Safety Precautions, before starting work.

Symptoms and possible causes

Starter motor not turning or slow	1, 2, 3
Engine will not start	4, 5, 6, 7, 8, 9
Engine starts but stops again	6, 7, 8, 9
Engine difficult to start	6, 7, 8, 9
Engine does not reach correct speed at wide open throttle (WOT)	7, 8, 9, 10, 11, 12, 13, 18
Engine knocks	14
Engine runs unevenly	6, 7, 8, 9, 13, 14
Engine vibrates	18, 19
High fuel consumption	10, 11, 13, 15, 18
Black exhaust smoke	5, 13, 15, 18
Blue or white exhaust smoke	15, 25
Low oil pressure	16, 17
Engine coolant temperature too high	20, 21, 22, 23, 24
No or poor charging	2, 26

- | | | |
|-------------------------------------|--|--|
| 1. Discharged battery | 11. Fouling on underwater hull/drive/propeller | 19. Defective engine mounting |
| 2. Loose connection/open-circuit | 12. Limited speed control lever movement | 20. Too little coolant |
| 3. Fuse tripped | 13. Insufficient air supply | 21. Blocked seawater intake/pipe/filter |
| 4. Stop control pulled out | 14. Engine coolant temperature too high | 22. Circulation pump drive belt slipping |
| 5. Inadequate pre-heating | 15. Engine coolant temperature is too low | 23. Defective impeller |
| 6. Lack of fuel | 16. Lubricating oil level too low | 24. Defective/incorrect thermostat |
| 7. Fouled fuel filter | 17. Blocked fuel filter | 25. Lubricating oil level too high |
| 8. Air in the fuel injection system | 18. Defective/incorrect propeller | 26. Generator drive belt slipping |
| 9. Water/contaminants in the fuel | | |
| 10. Boat abnormally loaded | | |

Technical Data

General

	D2-55 B	D2-75A
Engine designation	4	4
No. of cylinders	84 mm (3.31 in)	84 mm (3.31 in)
Cylinder bore	100 mm (3.94 in)	100 mm (3.94 in)
Cylinder stroke	2.2 liters (134 in ³)	2.2 liters (134 in ³)
Overall cylinder displacement	Power, see sales literature	
Power, see sales literature		
Idling speed	850 ±25 rpm	850 ±25 rpm
Rotation, viewed from in front	Clockwise	Clockwise
Max. permitted rake backwards while running	20°	20°
Max. list while running	30°	30°
Valve clearance (stopped, cold engine)		
inlet and outlet	0.20 mm (0.0078 in)	0.20 mm (0.0078 in)
Weight, dry engine	225 kg (496 lb)	233 kg (514lb)

Lubrication system

Oil volume incl. oil filter, approx.:		
no engine inclination	10.5 liters (2.8 US gals)	10.5 liters (2.8 US gals)
Oil quality	VDS-2, ACEA E5, API CH-4	VDS-2, ACEA E5, API CH-4
Viscosity at -5° - +50°C*	SAE 15W/40, SAE 20W/50	SAE 15W/40, SAE 20W/50
Oil drain plug tightening torque	30-40 Nm (22-30 lbf.ft)	30-40 Nm (22-30 lbf.ft)

* Constant ambient air temperature

Cooling system

Thermostats, no.	1 screws	1 screws
The thermostat starts opening at	82° ±2°C (176-183°F)	83° ±2°C (178-185°F)
fully open at	95°C (203°F)	95°C (203°F)
Freshwater system capacity, approx.	9.5 liters (2.5 US gals)	9.5 liters (2.5 US gals)

Electrical system

System voltage	12 V	12 V
Fuses	15A	15A
Battery capacity (starter battery)	70 Ah	70 Ah
AC generator voltage/max. current	14 V/60 A	14 V/115 A
output approx.	840 W	1610 W
Starter motor, output approx.	2.0 kW	2.0 kW

Reverse gear

MS25

Type designation	MS25L	MS25A
Gear ratio		
Left rotating (Position B)	2.27:1 ; 2.74:1	2.23:1 ; 2.74:1
Right rotating (Position A)	2.10:1 ; 2.72:1	2.74:1
Angle (output shaft):	0°	8°
Oil volume, approx.	1.05 liters (0.28 US gals)	0.75 liters (0.2 US gals)
Oil grade	CD SAE 15W/40* or ATF (Dexron II, III)*	CD SAE 15W/40* or ATF (Dexron II, III)*
Weight	25 kg (55 lbs)	25 kg (55 lbs)

HS25

Type designation	HS25A
Gear ratio	2.29:1 ; 2.71:1
Angle (output shaft)	8°
Oil volume, approx.	1.8 liters (0.48 US gals)
Oil grade	ATF (Dexron II, III)
Weight	31 kg (68 lbs)

Sailing boat drive

Type designation	MS25S, MS25SR	150S, 150SR
Gear ratio	2.19:1	2.19:1
Oil volume, approx.	2.0 liters (0.53 US gals)	3.25 liters (0.86 US gals)
volume difference min.-max.	0.3 liters (0.08 US gals)	0.1 liters (0.03 US gals)
Oil grade	CD	ATF
Viscosity	SAE 15W/40	
Weight	32 kg (71 lbs)	31 kg (68 lbs)
Tightening torque:		
oil drain plug	10 ±5 Nm (7.4 ±3.7 lbf.ft)	10 ±5 Nm (7.4 ±3.7 lbf.ft)

*  **WARNING!** Never mix oil qualities when topping up, the same oil quality must be used that already is filled in the reverse gear.

Fuel specification

Fuel must meet national and international standards at least. For example:

EN 590 (with national environmental and cold standards)

ASTM D 975 No 1-D and 2-D

JIS KK 2204

Sulphur content: According to statutory requirements.

Fuels with low density ("urban diesel" in Sweden and "city diesel" in Finland) can cause a drop in output of 5% and an increase in fuel consumption of 2–3%.

ENG

Post or fax this coupon to:

Document & Distribution Center
Order Department
ARU2, Dept. 64620
SE-405 08 Göteborg
Sweden
Fax: +46 31 545 772

Orders can also be placed via the Internet:

<http://www.volvopenta.com/manual/coupon>

Yes please,

I would like an operator's manual in English at no charge.

Publication number: 774 3646

Name

Address

Country

NB! This offer is valid for a period of 12 months from delivery of the boat. Availability after this period will be as far as supplies admit.

**VOLVO
PENTA**

42200/615001/155099900192

GER

Schicken Sie den Coupon per Post oder als Fax an:

Document & Distribution Center
Order Department
ARU2, Dept. 64620
SE-405 08 Göteborg
Schweden
Fax: +46 31 545 772

Die Bestellung kann auch über das Internet erfolgen:

<http://www.volvopenta.com/manual/coupon>

Ja,

ich will kostenlos eine Betriebsanleitung in deutscher Sprache erhalten.

Publikationsnummer: 774 3647

Name

Anschrift

Land

Bitte beachten Sie, dass dieses Angebot für die Dauer von 12 Monaten ab dem Lieferdatum des Bootes gilt, danach bis zum Aufbrauchen des Lagerbestandes.

**VOLVO
PENTA**

42200/615001/155099900192

FRE

Envoyez ou faxez le bon de commande à:

Document & Distribution Center
Order Department
ARU2, Dept. 64620
SE-405 08 Göteborg
Suède
Fax: +46 31 545 772

Vous pouvez également passer la commande par Internet:

<http://www.volvopenta.com/manual/coupon>

Oui merci,

Je souhaite recevoir un manuel d'instructions gratuit en français.

Numéro de publication: 774 3648

Nom

Adresse

Pays

Notez que l'offre est valable pendant 12 mois à partir de la date de livraison du bateau, ensuite seulement en fonction des stocks disponibles.

**VOLVO
PENTA**

42200/615001/155099900192

SPA

Franquear o enviar fax a:

Document & Distribution Center
Order Department
ARU2, Dept. 64620
SE-405 08 Göteborg
Suecia
Fax: +46 31 545 772

El pedido puede hacerse también por internet:

[http://www.volvopenta.com/
manual/coupon](http://www.volvopenta.com/manual/coupon)

Sí gracias,

deseo recibir gratuitamente un libro de instrucciones en español.

Número de publicación: 7743649

Nombre

Dirección

País

Nótese que el ofrecimiento vale durante 12 meses después de la fecha de entrega de la embarcación, y posteriormente solamente mientras duren las existencias.

**VOLVO
PENTA**

42200/615001/155099900192

ITA

Spedire il tagliando per posta o per fax a:

Document & Distribution Center
Order Department
ARU2, Dept. 64620
SE-405 08 Göteborg
Svezia
Fax: +46 31 545 772

L'ordinazione può essere fatta anche su Internet:

[http://www.volvopenta.com/
manual/coupon](http://www.volvopenta.com/manual/coupon)

Sì, grazie,

desidero ricevere gratuitamente un manuale d'istruzioni in lingua italiana.

Public. No.: 7743651

Nome e Cognome

Indirizzo

Paese

Si ricorda che l'offerta è valida per 12 mesi dalla data di consegna dell'imbarcazione; dopo il suddetto periodo l'offerta resta valida solo in base alla disposizione della pubblicazione in oggetto.

**VOLVO
PENTA**

42200/615001/155099900192

SWE

Posta eller faxes kupongen till:

Dokument & Distribution center
Ordermottagningen
ARU2, Avd. 64620
SE-405 08 Göteborg
Sverige
Fax: +46 31 545 772

Beställningen kan även göras via internet:

[http://www.volvopenta.com/
manual/coupon](http://www.volvopenta.com/manual/coupon)

Ja tack,

jag vill kostnadsfritt ha en instruktionsbok på svenska.

Publikationsnummer: 7743645

Namn

Adress

Land

Observera att erbjudandet gäller i 12 månader från båtens leveransdatum, därefter endast i mån av tillgång.

**VOLVO
PENTA**

42200/615001/155099900192

DUT

Stuur of fax de coupon naar:

Document & Distribution Center
Order Department
ARU2, Dept. 64620
SE-405 08 Göteborg
Zweden
Fax: +46 31 545 772

U kunt ook bestellen via internet:

[http://www.volvopenta.com/
manual/coupon](http://www.volvopenta.com/manual/coupon)

Ja graag,

Ik wil kosteloos een instructieboek in het Nederlands ontvangen.

Publicatienummer: 774 3654

Naam

Adres

Land

Denk eraan dat het aanbod geldt gedurende 12 maanden na de datum waarop de boot werd afgeleverd, daarna alleen indien nog verkrijgbaar.

**VOLVO
PENTA**

42200/615001/155099900192

DAN

Send kuponen med post eller fax til:

Document & Distribution Center
Order Department
ARU2, Dept. 64620
SE-405 08 Göteborg
Sverige
Fax: +46 31 545 772

Bestillingen kan også ske på internet:

[http://www.volvopenta.com/
manual/coupon](http://www.volvopenta.com/manual/coupon)

Ja tak,

jeg vil gerne gratis have en instruktionsbog på dansk

Publikationsnummer: 774 3652

Navn

Adresse

Land

Bemærk at tilbudet gælder i 12 måneder fra bådens leveringsdato, Derefter kun så længe lager haves.

**VOLVO
PENTA**

42200/615001/155099900192

FIN

Postita tai faksaa kuponki osoitteella:

Document & Distribution Center
Order Department
ARU2, Dept. 64620
SE-405 08 Göteborg
Ruotsi
Fax: +46 31 545 772

Tilauksen voi tehdä myös Internetissä:

[http://www.volvopenta.com/
manual/coupon](http://www.volvopenta.com/manual/coupon)

Kyllä kiitos,

haluan suomenkielisen ohjekirjan veloituksetta.

Julkaisunumero: 773653

Nimi

Osoite

Maa

Huomaa, että tarjous on voimassa 12 kuukautta veneen toimituspäivämäärästä lukien ja sen jälkeen vain niin kauan kuin kirjoja riittää.

**VOLVO
PENTA**

42200/615001/155099900192

POR

Envie o talão pelo correio ou um fax para:

Document & Distribution Center
Order Department
ARU2, Dept. 64620
SE-405 08 Göteborg
Suécia
Fax: +46 31 545 772

A encomenda também pode ser feita através da Internet:

[http://www.volvopenta.com/
manual/coupon](http://www.volvopenta.com/manual/coupon)

Sim, obrigado(a)!

Gostaria de receber gratuitamente um manual de instruções em português.

Número de publicação: 7743655

Nome

Endereço

País

Observar que esta oferta é válida durante um período de 12 meses a contar da data de entrega do barco. Após este período, a oferta está dependente do número de exemplares disponíveis.

**VOLVO
PENTA**

42200/615001/155099900192

GRE

Ταχυδρομήστε αυτό το κουπόνι στην παρακάτω διεύθυνση ή στείλτε το με φαξ στον παρακάτω αριθμό φαξ:

Document & Distribution Center
Order Department
ARU2, Dept. 64620
SE-405 08 Göteborg
Sweden
Fax: +46 31 545 772

Μπορείτε επίσης να δώσετε την παραγγελία σας μέσω του Internet, στη διεύθυνση:

[http://www.volvopenta.com/
manual/coupon](http://www.volvopenta.com/manual/coupon)

Ναι,

Θα ήθελα ένα αντίτυπο του εγχειριδίου χρήσης στην αγγλική γλώσσα χωρίς καμιά χρέωση.

Αριθμός έκδοσης: 7743656

Όνομα

Διεύθυνση

Χώρα

ΠΡΟΣΟΧΗ: Αυτή η προσφορά ισχύει για χρονική περίοδο 12 μηνών από την παράδοση του σκάφους. Μετά το πέρας της εν λόγω χρονικής περιόδου η διαθεσιμότητα των αντιτύπων θα εξαρτάται από την ποσότητα των αποθεμάτων.

**VOLVO
PENTA**

42200/615001/155099900192

