

Nanni marine engine

Operator's manual

Engines

N2.10

N2.14

N3.21



English

You can download a copy of this manual in English on nannidiesel.com.

Français

Vous pouvez télécharger ce manuel en Français sur notre site Web à l'adresse www.nannidiesel.com.

Italiano

Scarica una copia del manuale in lingua Italiano sul nannidiesel.com.

Deutsch

Sie können eine Kopie dieses Handbuchs in Deutsch Sprache auf nannidiesel.com.

1

CONTENTS

Introduction	1	Maintenance	32
About this manual	2	Service schedule.....	33
Safety.....	3	General inspection.....	35
Emergency kit	3	Fuel system	37
Safety alert symbols	3	Lubrication system	41
Safety icons	4	Cooling system	43
Safety precautions	5	Raw water system	47
Overview	9	Electrical system	51
About the engine	9	Battery	52
About the propeller	14	Corrosion protection	54
Behaviour of the boat	14	Long term storage	57
Engine main components	15	Troubleshooting.....	59
Instruments panel.....	19	Technical data	61
Standard panel	19		
Instrumentation	20		
Operation	25		
Before starting	25		
Starting the engine	26		
During operation	28		
Stopping the engine	30		

Thank you for choosing a Nanni product!

Contact a Nanni authorized dealer for the servicing of your product. A list of dealers can be found on our web site:

www.nannidiesel.com

Nanni engines are the product of many years of experience in the development of marine engines and equipment designed for use in open seas. Your engine is built with the finest materials in accordance with precise specifications and strict production methods.

Before operating the engine, make sure that this manual is applicable to the engine. Refer to the Identification plate if you are not sure about the engine model designation. If you don't have the correct manual, please contact your Nanni authorized Dealer.

Correct installation of the engine on your boat is of the greatest importance for safe navigation and protection of the environment. The installation should be carried out by an authorized Nanni workshop in accordance with the installation instructions.

About this manual

This Operator's Manual contains important information, tips, suggestions and warnings. We urge you to read it carefully and familiarize yourself with the engine before starting.

For your own safety and longer service life of the engine, follow the instructions and warnings contained in this manual and in all documentation provided with the boat. Ignoring them could result in damage to the engine or personal injury to you or others.

Please ensure that this Manual is always kept in the boat. It should always be available to anyone else using the engine, i.e. anyone renting, borrowing or buying the engine from you. Throughout the document, the following symbols are used to ease the reading:

→ Indicates that the text is continued on the following page.

■ Indicates the end of a section.

Content and updates

All the informations and specifications in this Manual are based on the technical data applicable at the time of its publication. Changes and updates may be made by Nanni without notice.

Illustrations are intended as a general guide, and may vary from the equipment fitted in the engine in some details. Some sections of the Manual do not apply to all engines. If this is the case, a text indicates which engines it applies to.

If there are any equipment details that are not shown or described in this Operator's Manual, or if you have any questions about the operation of any equipment, your authorized Nanni Dealer will be glad to inform you of correct care and operating procedures.



Read this chapter carefully as it concerns your safety. Most accidents are caused by failing to follow basic safety rules. Be aware of the possible risks involved in handling the engine and make sure to take the necessary precautions to protect yourself, those around you and the equipment.

Read all informations supplied with the boat before starting the engine for the first time.

Always ensure that the maintenance of the boat and all equipment has been done in accordance with the instructions stated in the relevant Manual. Have all mandatory and necessary safety equipment handy in the boat and serviceable.

Emergency kit

You can order an emergency kit from any Nanni authorized dealer.

The engine emergency kit contains several components to carry out simple repair in the event of a fault.

Always have an complete emergency kit onboard and necessary tools to carry out any repairs.



Safety alert symbols

General rules of safety precautions to follow are indicated in this Manual. They are indicated as follows:

DANGER

Indicates a hazardous situation which, if not avoided, will result in death or serious injury.

WARNING

Indicates a hazardous situation which, if not avoided, could result in death or serious injury.

CAUTION

Indicates a hazardous situation which, if not avoided, could result in minor or moderate injury, or could cause property damage.

NOTICE: Indicates important information in order to facilitate handling or avoid property damage.



Safety icons

Several stickers are fixed directly on the engine. They are intended to help you to quickly identify the location of certain components and avoid possible hazards when working on the engine.

Ensure these stickers are always visible and change them if necessary.



Refers to important informations and instructions to follow before handling the engine.



Indicates possible electrical hazards.



This icon indicates a risk of fire.



Indicates hot parts entailing substantial risks of burns.



Indicates an area containing pressurised fluids.



Stipulates that no flames or sparks should be created in the vicinity.



Indicates hazardous rotating parts.



Indicates the de-aeration orifice(s) (air bleed).



Indicates where to check the coolant level.



Indicates where to check the engine oil level.



Indicates the coolant drain orifice.



Indicates the oil drain orifice.



Safety precautions

Exhaust gas

Exhaust gases contain carbon monoxide. This colourless and odourless gas is extremely harmful and could lead to poisoning which could result in loss of consciousness or death. The first symptoms of carbon monoxide intoxication are as follows:

- Dizziness
- Nausea
- Headache
- Throbbing temples
- Vomiting
- Fatigue and falling asleep
- Tense muscles

If you or anyone else in the vicinity of the engine experiences any of these symptoms, leave the area of operation of the engine and find fresh air. If the symptoms persist, consult a doctor and have the engine checked.

Ensure the exhaust circuit correctly expels the gas produced by the engine. Regularly check that the exhaust circuit is free of leaks and that the exhaust elbow is in good condition.

Burns

Never touch the hot parts of the engine! An operational engine gets very hot: the exhaust system, turbocompressor (if equipped), starter, oil sump, oil, coolant in the hoses and pipes are hot and can burn.

Fluids ejected under pressure can cause serious injury. Release all the pressure in the circuits before removing the caps. Never open the oil circuit and coolant caps when the engine is operational and/or hot. Never start or run the engine when the oil fill and coolant caps are not screwed on as hot oil or coolant could spray out.

If you come into contact with any of these fluids, consult a doctor immediately. If the engine gets too hot, switch it off and disconnect it and wait for it to cool down before checking for failure.

Fire

Do not smoke near the engine and keep it away from sources of ignition (flames or sparks) or any other potential flammable vapour or liquid sources. Do not run the engine without the air filter.

Do not run the engine in an area in which flammable or explosive materials are stored or where gas is present. Ensure there are no flammable liquids in the engine compartment.

Immediately clean up any liquids spilled and keep the engine compartment clean and accessible so as to minimise the risk of fire. Be careful as fuel can burn. Damaged pipes can lead to fire.

Explosion

Explosions caused by fuel vapour can cause serious injury! Carefully follow the safety rules when filling the fuel.

Open and ventilate the storage area of the engine after filling. Check that there are no fuel vapours or leaks before starting the fan (if fitted). Switch the fan on for 5 minutes before starting the engine.

All fuel vapours are flammable and explosive. Be careful when handling and storing fuel. Store the fuel in a ventilated area away from sources of ignition (sparks or flames) and out of the reach of children.

Stop the engine before filling with fuel or lubricant. Do not smoke near the engine and keep it away from sources of ignition (flames) when filling with fuel and/or lubricant. Wear gloves when investigating possible leaks.

Do not alter or damage the fuel circuit. Close the fuel circuit whenever you work on it. Ensure you always have an appropriate working fire extinguisher to hand.

Hazardous Voltage/ Electrical Shock

Electrocution is possible whenever electricity is present. Hazardous voltage can cause severe injury or death. Operate the engine only when all guards and electrical enclosures are in place.

Open the main circuit breakers of all power sources before servicing the equipment. Configure the installation to electrically ground the engine, transfer switch, and related equipment and electrical circuits to comply with applicable codes and standards.

Never contact electrical leads or appliances when standing in water or on wet ground because these conditions increase the risk of electrocution. The voltage at these terminals can cause death.

Short circuits can cause bodily injury and/or equipment damage. Remove all jewellery before servicing the equipment.

Hazardous backfeed voltage can cause severe injury or death. Connect the engine to the building/marina electrical system only through an approved device. Work on the electrical circuit should only be carried out by qualified technicians.

Operations on the shore power equipment must only be carried out by electricians authorized to work with high voltage installations.

Special attention must be brought on boat with metallic hull, especially concerning the protection of the persons against electrical shock and the protection against galvanic and electrolytic corrosion.

Battery acid

The acid in batteries can cause serious injury and even death!

When servicing the batteries, wear protective gloves and goggles. Batteries contain sulphuric acid which is highly corrosive.

Acid can spurt from batteries when they are handled. If the acid comes into contact with the skin, rinse thoroughly in fresh water and consult a doctor.

Risk of battery explosion

A battery explosion can cause serious injury and even death! Ensure the battery storage compartment is corrected ventilated.

Do not smoke near the batteries and keep them away from sources of ignition (flames or sparks). They produce hydrogen which could ignite or explode on contact with an electrical arc or a flame.

Switch off all electrical appliances in the vicinity when you are working on the batteries.

Ventilate correctly storage batteries compartment. Avoid touching the battery terminals with metal tools so that no sparks are created which could cause an explosion. Remove the rings, bracelets and necklaces before handling the batteries.

Rotating parts

Rotating parts can be extremely dangerous and cause serious injury and even death!

Do not work on the engine when it is operational. If work on the engine when running is absolutely necessary, do not touch any hot or rotating parts.

Baggy clothing, hair or objects could be pulled in and/or caught and cause serious injury or substantial property damage.

Do not wear bracelets, necklaces or rings when working on a engine. Check that the bolts and screws are properly tightened and that the protection mechanisms are in place. Do not check the tension of the alternator belt when the engine is operational.

Accidental starting

Accidental starting can cause serious injury and even death!

Disconnect the battery before working on the engine. Ensure no one is alongside the engine or working on before starting it. A rotating propeller can cause serious injury or death. Ensure all the protection mechanisms are in place before starting the engine.

Chemical products

The different fluids used to run the engine are a health hazard. Carefully read the instructions on the packaging of these products and always check that the ventilation in the hold space is adequate.

Follow environmental regulations concerning the disposal of oil, fuel, coolant, filters and batteries. Do not put your hands over pipes when looking for possible leaks.

Water ingress

The engine should be protected against from water ingress by any means. Water ingress leads to complete engine failure. This is not cover under any warranty terms.

Water can enter the engine after filling the exhaust system.

Correct installation of the engine on your boat is of the greatest importance for safe navigation and pro-

tection of the environment. The first protection against water ingress is a correct installation of the engine.

A correct use of the engine is also important to protect the engine against water ingress. The operator/owner is responsible for the correct operation of the engine and for the implementation of all necessary means to protect the engine against water intrusion.

After a vessel capsizing, or if the engine has been filled with water, do not start the engine, except in extreme emergencies, and contact an authorized Nanni dealer.

About the engine

Engine identification

Both the engine and the transmission has an identification plate that contain several informations.

Keep these plates accessible and in good condition. Record and keep the engine and transmission serial number and designation. These numbers should always be quoted when ordering service and replacement parts.

The engine identification plate is as follow:



- **TYP** indicates the commercial designation of the engine.
- **NR** indicates the engine serial number.
- **CODE** lists various specifications of the engine.

Break in

Operate the engine with care for the first 50 hours of operation.

Do not race the engine while it is cold. Do not operate it at full load except for short periods. Never run the engine at constant engine speed for long periods during the break in period.

Check the oil and coolant level frequently during the running-in period. The oil consumption can be more important during the running-in period.

Engine installation

The installation must be carried out by an authorized Nanni workshop in accordance with the installation instructions. Correct installation of the engine is of the greatest importance for safe navigation and protection of the environment.

It also ensure maximum service life under normal conditions of use.

Engine damage caused by failure to follow installation instructions is not covered by the warranty.

Remote Control

The remote control is an optional extra not in the scope of supply of the engine. The remote control installed on the boat can be different than the ones shown in this document.

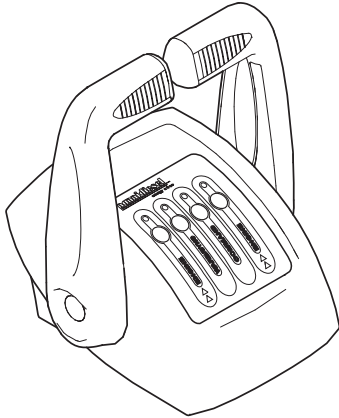

On most boats, the control lever controls both the engine rpm and the gear shift (ahead / astern). However, some boats can be equipped with a separated shift command.

It can also be fitted with a neutral safety switch that prevents the engine from starting until the lever is in neutral position.

Consult the boat builder or your Nanni dealer if you are not sure about the operation of the remote control.

Power Take Off

Some engines can be fit with a Power Take Off system. This system allows to power accessories like bilge pump, watermaker, etc.

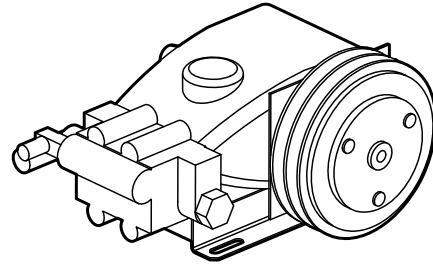

NOTICE: Any mechanical power taken from the engine from a PTO reduces the power delivered to the propeller. The use of a PTO should always be studied and approved by the R&D department of Nanni Industries S.A.S France. Contact your Nanni dealer for more informations.

Trolling valve

The Trolling valve system allows to reduce the rotation speed of the propeller below its speed when the engine is at idle. The boat speed is reduced by 30% to 70%.

⚠ CAUTION

The Trolling valve system must never be used for manoeuvring. It also must never be used at an engine speed of more than 1200 rpm.

Operation in cold weather conditions

Nanni engines are designed to operate effectively in cold weather.

However, for effective starting and cold weather operation, extra care are necessary. Contact your Nanni dealer for additional information and local availability of cold weather aids.

WINTER GRADE FUEL

Winter grade fuel allows to protect the injection system when temperatures fall below 5°C (40°F). Winter grade fuel is best suited for cold weather operation thanks to its lower cloud and lower pour points.

However, using winter grade fuel may reduce power and fuel efficiency as winter grade fuel has a lower BTU (heat content) rating. Check the grade of fuel being used before troubleshooting for low power complaints in cold weather operation.

In all cases, fuel quality and fuel sulfur content must comply with all existing emissions regulation for the area in which the engine operates.

Oil viscosity

Use seasonal grade viscosity engine oil based on the expected air temperature range between oil changes.

Follow the diagram below to adapt the oil viscosity:

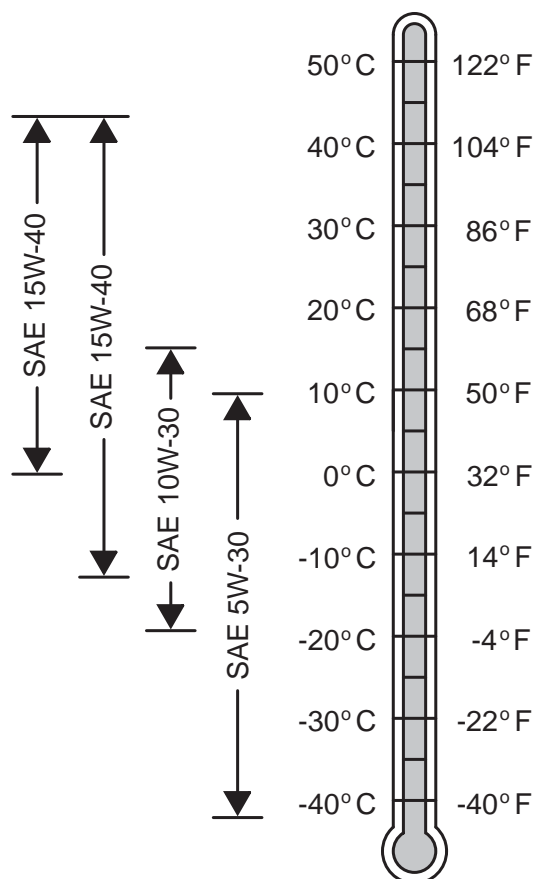

As an option, some engines are available with an air intake heater to aid cold weather starting. Contact your Nanni dealer for more informations.

Engine homologation

The engine type can be exhaust emission certified. It means that Nanni guarantees that all engines of the same type that are manufactured are approved and certified by the authorities in accordance with different exhaust emissions standards.

However, for the engine to be in accordance with this standards, special requirements for maintenance and service are to be followed:

- Only Nanni replacement parts must be used.
- Maintenance intervals must be observed.
- The engine must not be modified in any way except with accessories and service kits approved by Nanni Industries S.A.S. France.
- Service of the fuel system must always be carried out by an authorized Nanni workshop.
- No modifications to the air intake and exhaust system may be undertaken.
- Seals may only be broken by authorized personnel.
- The operation instructions stated in the relevant manuals should be followed by the user.

Nanni's responsibility for the engine specification being in accordance with the certification will be invalidated if one or several of these conditions are not followed.

Environmental responsibility

Nanni designs its engines to have minimum environmental impact. This objective, however, can only be achieved with your full cooperation.

Our operating and maintenance instructions are to help you to protect your engine and adopt environmentally responsible behaviour.

Ensure you only use the fuels and oils recommended. Using another type of fuel or oil could cause major malfunctions, a higher fuel consumption, a reduced engine service life, and a greater discharge of exhaust gases.

When draining the oil and changing the oil or fuel filter, dispose of the waste in an appropriate container.

These fluids cause major damage to flora and fauna if discharged into nature. Use an absorption kit in the event of accidental discharge of oil or fuel into the water.

Warranty

This manual is supplemented by a Warranty Information Booklet. We recommend that you read this publication thoroughly.

Pay special attention to the applicable duty cycle and to the limitations that result. Failure to comply with the warranty conditions will void the Warranty.

The validity of the Warranty is also dependent on proper installation and maintenance operation being carried out by an authorized Nanni representative.

NOTICE: Late or improper maintenance or use of spare parts other than Nanni original spare parts will invalidate Nanni's responsibility for the engine accordance with homologation and will void the Warranty.

Modifications to the engine's settings, as well as any other technical modification (accessories, spare parts, additional equipment, etc) **ARE FORBIDDEN WITHOUT WRITTEN AUTHORIZATION FROM NANNI INDUSTRIES S.A.S.**

Any modification will void the Warranty. Damage caused by failure to follow operation instructions or incorrect operation is also not covered by the warranty.

Commissioning inspection

Commissioning inspection is a condition of the validity of the Limited Warranty. Moreover, it allows the registration of the product at the factory and record important informations regarding the product.

By registering the product, you will receive the best warranty coverage possible and Nanni will be able to contact you in the event of updates or service notifications.

Operations to be performed during commissioning inspection are specified in the Warranty Booklet. The commissioning inspection must be signed by the seller and the owner of the engine.

It's the owner responsibility to control that the commissioning inspection has been fully completed and signed by the person who carried out the inspection.

The informations regarding the RPM must be taken using an electronic tachometer. Never use the tachometer of the instrument panel for this purpose.



About the propeller

The propeller is a critical component of the propulsion system. It converts the engine power in thrust. To be efficient, the propeller must be perfectly adapted to the boat and to its use.

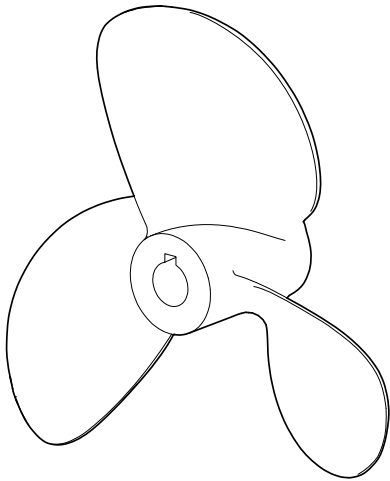

In all cases, the propeller should allow the engine to reach its rated rpm with the maximum boat load.

A faulty operation of the engine is often due to an inadequate and / or damaged propeller.

Behaviour of the boat

If this is your first boat or if you are not familiar with the boat, we urge you to practice controlling the boat at slow speed as a first step.

Avoid violent manoeuvres or unexpected speed changes while sailing. People can fall over or overboard.

Keep also in mind that the weight distribution (passengers, equipments, etc.) inside the boat has an impact on the behaviour of the boat when cruising. Depending the position of the load, the behaviour of the boat may change, particularly in the case of a planning hull.

The condition of the hull and the propeller is also a critical factor. A dirty and / or damaged hull will modify the behaviour of the boat and therefore the engine performance. It can also cause cavitation which can seriously erode the surface of the propeller, the drive, etc.

Engine main components

NOTICE: The engine may not be exactly as represented here. Some components may not be part of the engine ordered.

<i>P/N</i>	<i>COMPONENTS</i>
1	Alternator
2	Alternator belt
3	Starter
4	Fuses box
5	Air filter
6	Fuel filter
7	Fuel feed pump
8	Fuel injection pump
9	Heat exchanger
10	Coolant filler plug
11	Coolant pump
12	Recovery tank
13	Coolant drain plug
14	Raw water pump
15	Oil filter
16	Oil filler port
17	Oil gauge
18	Water cooled exhaust elbow
19	Transmission

N2.10

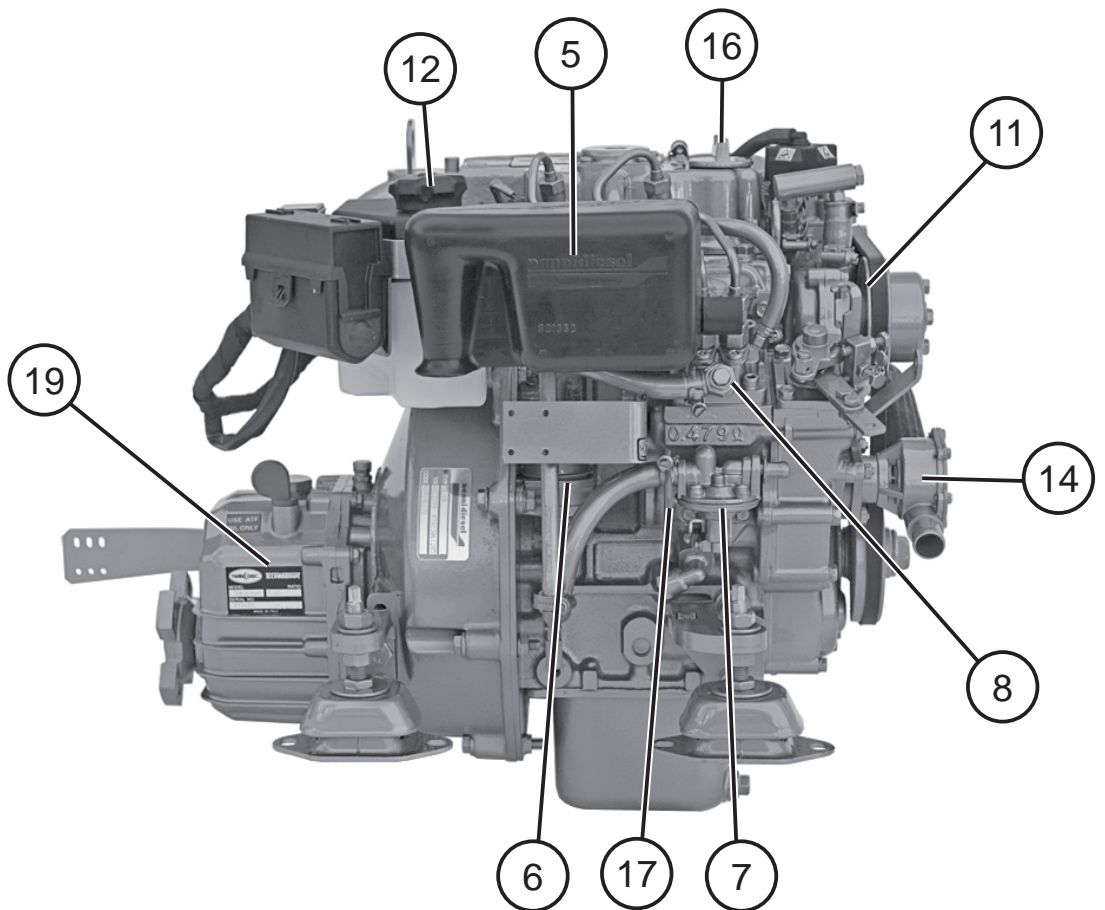
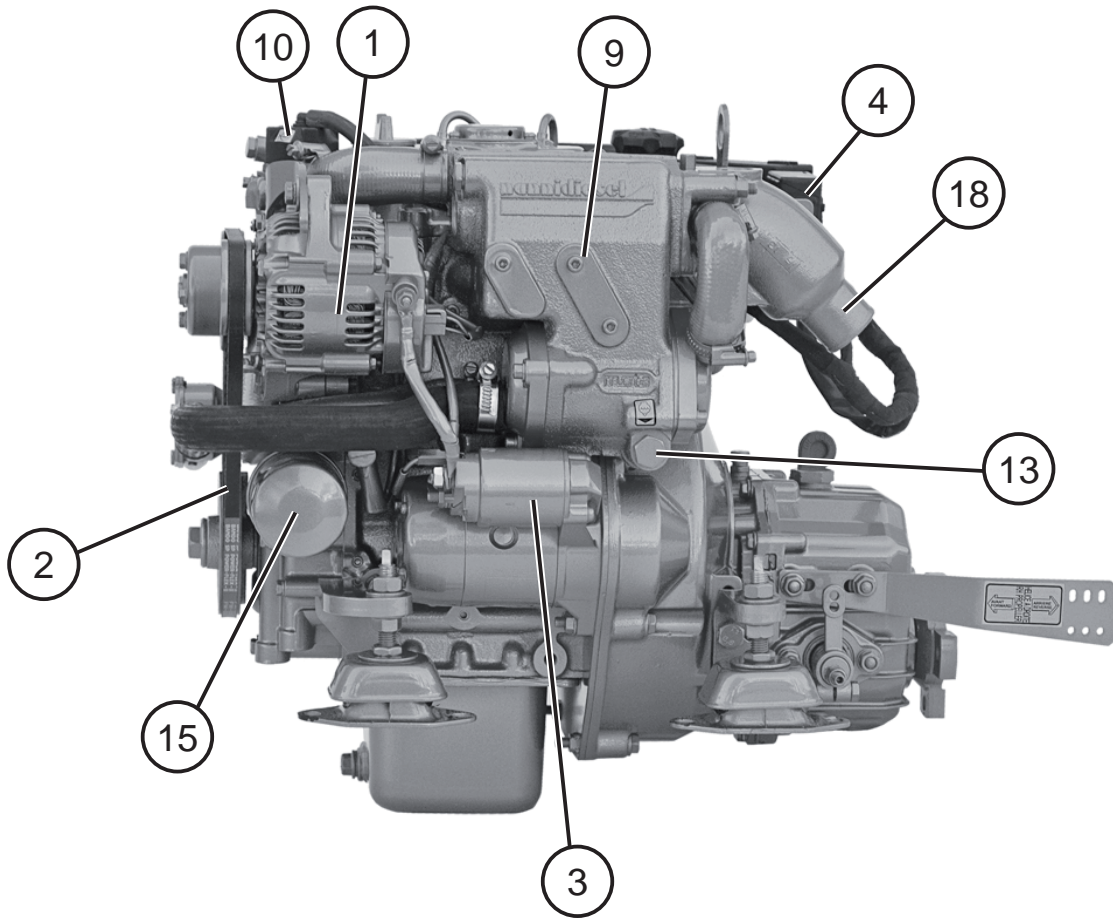

N2.14

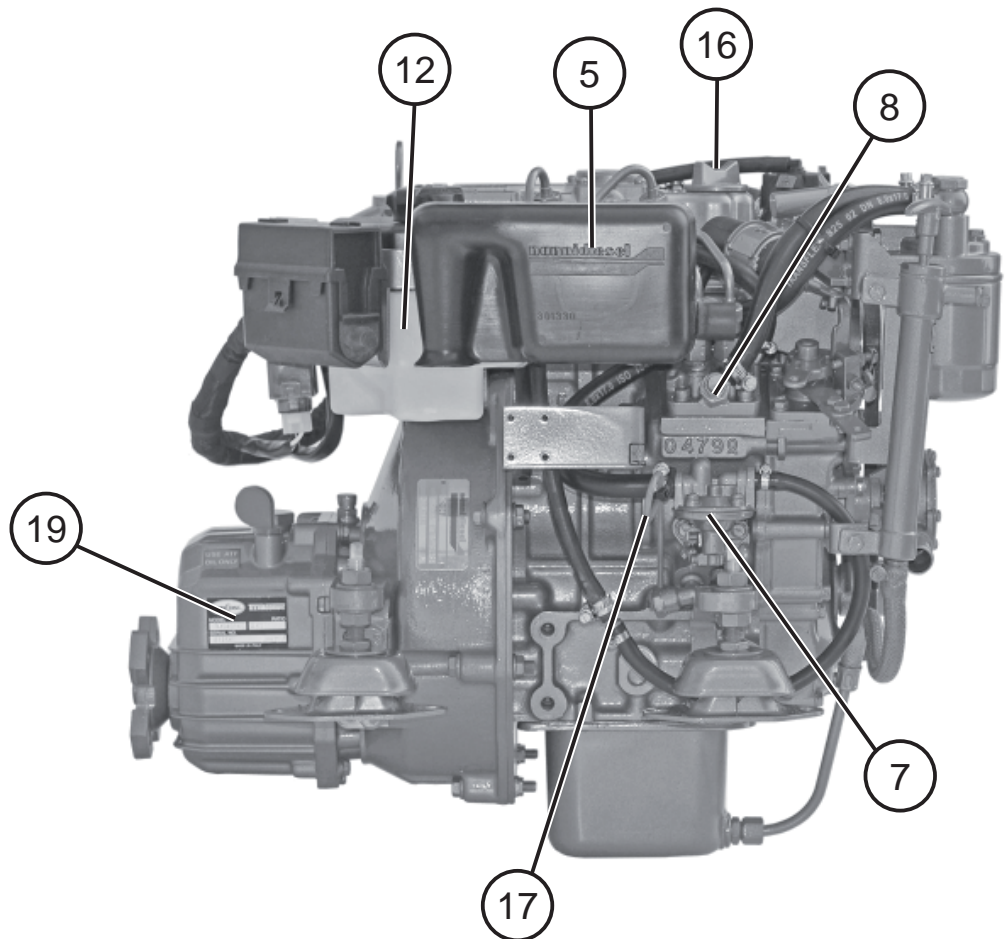
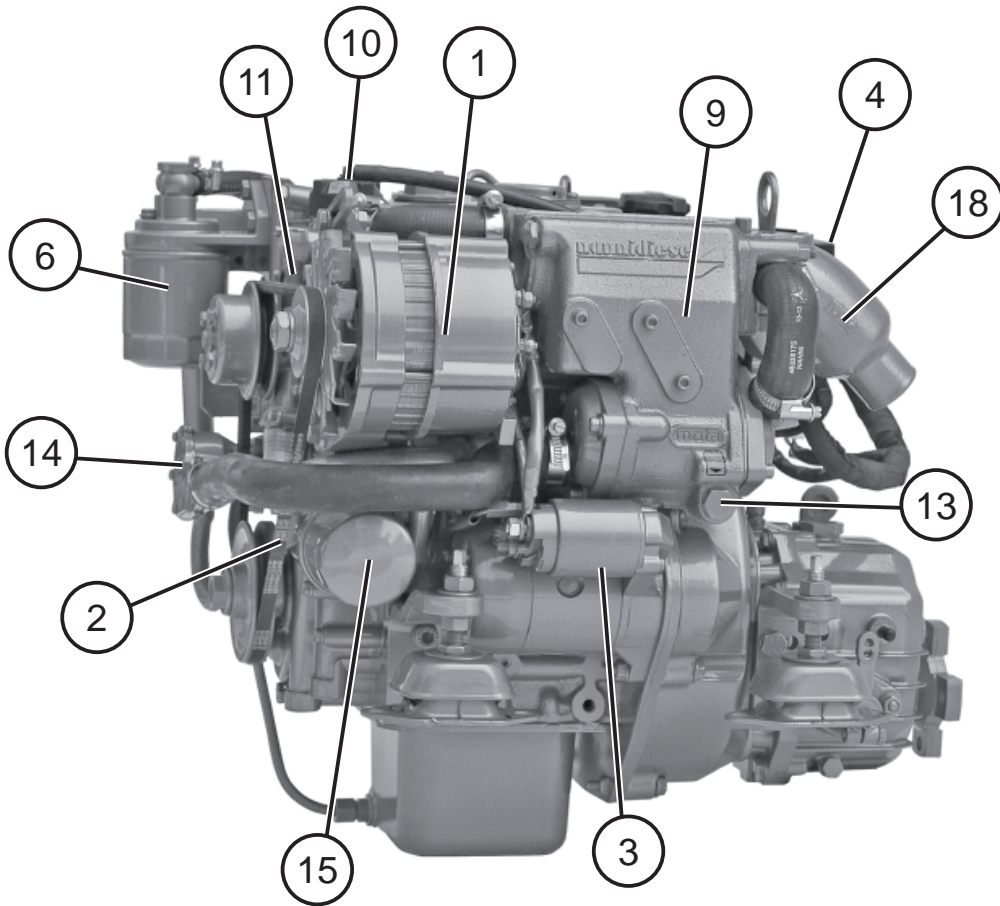

N3.21

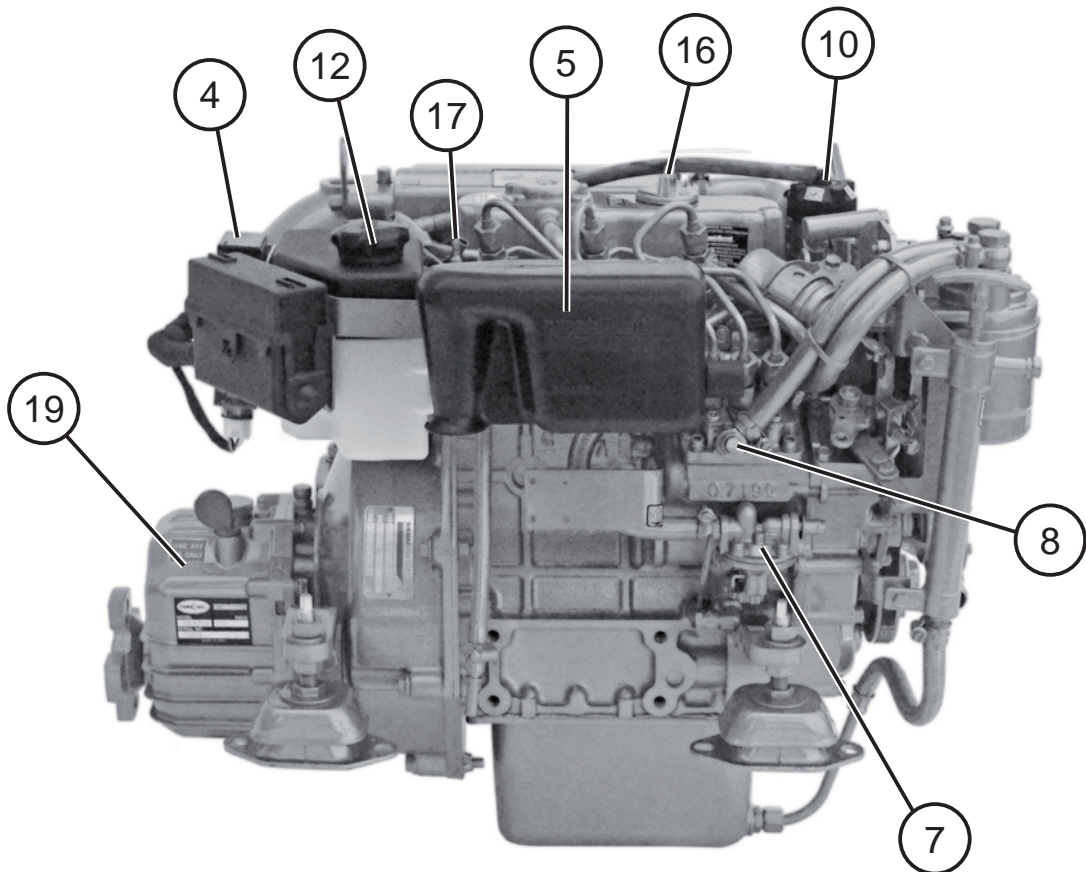
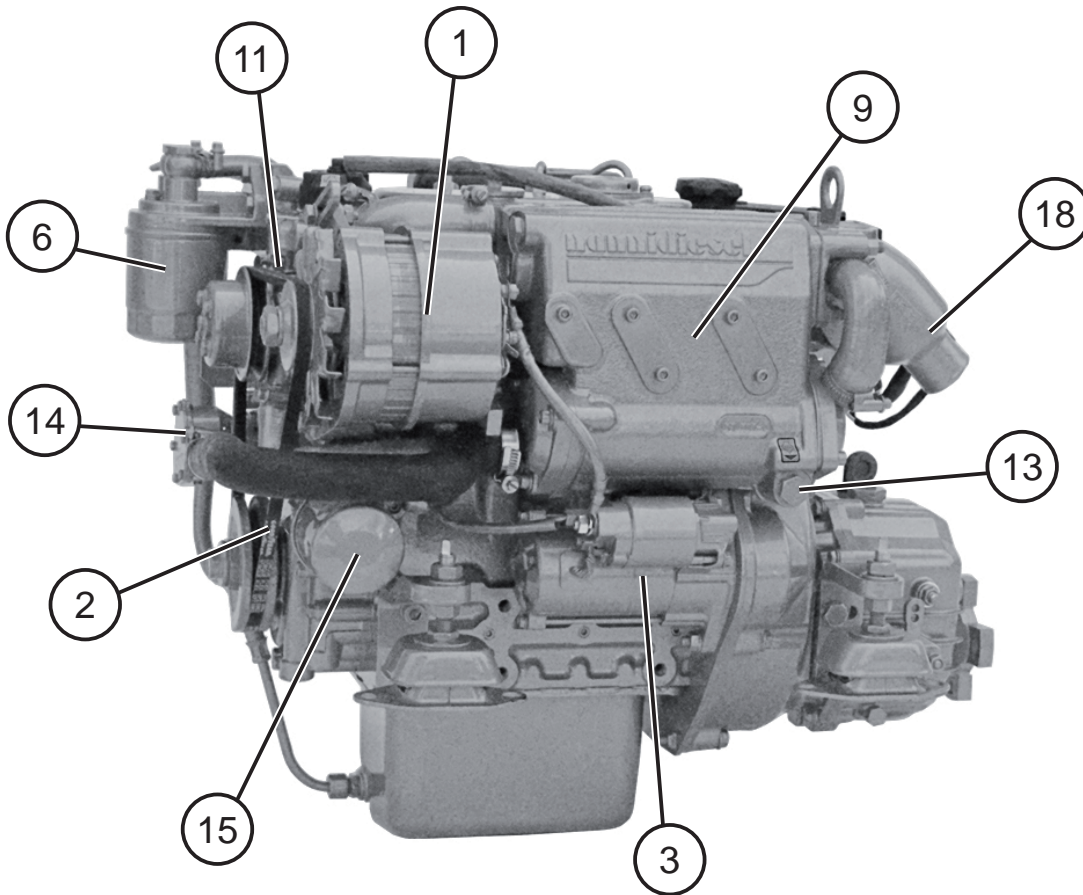

5

INSTRUMENTS PANEL

⚠ WARNING

Read the starting and stopping instructions before operating the engine.

The instrument panel provides you with important informations about the engine.

NOTICE: This chapter only describes instruments and panels that come standard on Nanni engines. Contact your dealer if the boat is fitted with instruments not described in this chapter or if you are not sure about their function. Depending the boat, the warning lamps and the instruments can be installed separately without the panel shown here.

On some boats, a panel without key is used as an additional instrument panel in Flying Bridge position. A main panel fitted with a key switch generally located in the wheel-house is used to prevent unauthorized starting from the additional panel. To start the engine using the additional panel, the key of the main panel should be switched to **IGNITION** position.

Standard panel

ECO4 PANEL



NOTICE: The Eco4 panel is only available with the engine model N2.10.

A4 PANEL

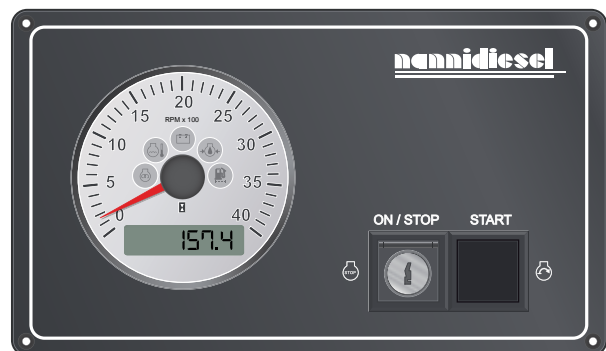

C4 PANEL

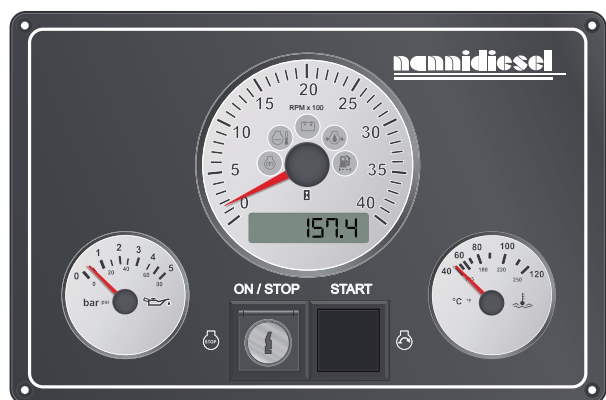

Instrumentation

Tachometer & Warning lamps

The analog tachometer displays the engine speed. Multiply the indicated value by 100 to get the revolutions per minute of the engine.

The function of the warning lamps is explained in the following pages.



Hourmeter & Voltmeter

The display at the bottom of the dial shows the operating time of the engine in hours

When the system voltage is connected, the display indicates the voltage at the battery terminals.

Starter switch

The starter switch allows to start and stop the engine.

The **ON/STOP** switch allows to connect the system voltage and to stop the engine.

The **START** button allows to pre-heat the engine and engage the starter.

NOTICE: As standard, the engine model N2.10 is not fit with an electric stop function. A mechanical stop control has to be installed to stop the engine.



Engine oil pressure indicator

NOTICE: This indicator does not show the engine oil level. This indicator shows the oil pressure in bar and psi.

If the oil pressure in the lubrication circuit is too low, the acoustic alarm sounds and the corresponding warning lamp comes on.



Coolant temperature indicator

Indicates the coolant temperature in Celsius and in Fahrenheit degrees.

If the coolant temperature is too high, the acoustic alarm sounds and the corresponding warning lamp comes on.



Warning lamps

COOLANT TEMPERATURE



This warning lamp comes on and the alarm sounds when the coolant temperature is too high.

⚠ DANGER

Never open the coolant filler cap or any plug of the cooling system when the engine is warm. Steam or hot fluid can spray out.

⚠ CAUTION

* If this alarm comes on while the engine is running, stop the engine, except in extreme emergencies, and check the coolant level, the belt condition, the raw water filter condition, and that the sea cock is open.

* Operating the engine while the coolant temperature is too high can lead to severe engine damage. Do not operate the engine if the problem persists and contact a Nanni workshop as soon as possible.

BATTERY CHARGE

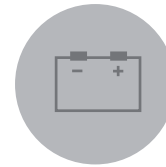

This warning lamp comes on when the system voltage is connected.

If this lamp lights up when the engine is running, it indicates that the alternator of the engine is not charging.

The cause can be a fault in the electrical system or because the alternator belt is slack.

⚠ CAUTION

* If this alarm comes on while operating the engine, stop the engine, except in extreme emergencies, and check components of the belt system. Also check components of the electrical system (fuses, battery, etc).

* Do not operate the engine if the problem persists and contact a Nanni workshop as soon as possible.



PREHEATING



This lamp comes on when the glow plugs (if fitted) are activated.

ENGINE OIL PRESSURE



This warning lamp lights up and the alarm sounds when the engine oil pressure is too low.

⚠ CAUTION

* If this alarm comes on while operating the engine, stop the engine, except in extreme emergencies, and check the engine oil level and the oil filter condition.

* Operate the engine when the oil pressure is too low can lead to severe engine damage. Do not operate the engine if the problem persists and contact a Nanni workshop as soon as possible.

WATER IN FUEL FILTER



This lamp lights up and the alarm sounds when there is too much water in the fuel filter of the engine (not applicable on some engines).

If this alarm comes on, stop the engine and drain the water in the fuel filter.

SYSTEM VOLTAGE

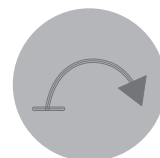

NOTICE: Only on Eco4 panel.

Indicates that the system voltage is connected.



6 OPERATION

Before starting

⚠ WARNING

Put all the protective covers back before starting the engine.

⚠ CAUTION

Open the sea cock (if equipped) before starting the engine. The raw water pump impeller will be damaged if it runs dry even for few seconds, and may lead to engine overheating.

Perform all of the following operations before starting the engine:

1. Open sea cock (if fitted). Prime the raw water system if necessary.

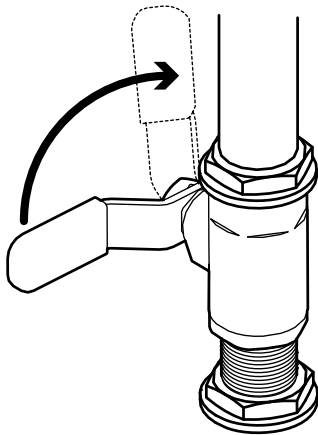

2. Start the compartment fan (if fitted) for at least five minutes. Otherwise, open the hold.

3. Check that there is sufficient fuel.

4. Move the control lever to the neutral position.

5. Open fuel cock, prime the system if necessary.

6. Check the engine and transmission oil level and fill with the recommended oil if necessary.

7. Check the coolant level, top up if necessary.

8. Check the control cables, grease the connections if necessary.

9. Check there are no fuel, oil, coolant or water leaks.

10. Check the alternator belt.

11. Switch ON the main switches.



Starting the engine

⚠ DANGER

* The propeller can cause serious injury when rotating. Check that nobody is in the water near the propeller before starting.

* Never use a start spray or any other equivalent product. These products are highly flammable.

⚠ CAUTION

* Always preheat the engine. Never race the engine while it is cold.

* Do not crank the engine continuously for more than 10 seconds at a time. Let it cool down for 2 minutes between cranking attempts. Failure to follow these guidelines may result in starter motor burnout.

* If the engine doesn't start after 3 attempts, remove the key and drain the water in the waterlock. Failure to do so may lead to water ingress in the cylinders.

NOTICE: When starting the engine for the first time, let it run at idle for several minutes and check for leaks or malfunction.

Starting using booster batteries

⚠ CAUTION

Make sure to use batteries with the same rated voltage as the engine's system voltage.

1. Connect the jumper cable to the positive pole (+) of the flat battery, then to the positive pole (+) of the booster battery.
2. Connect the jumper cable to the negative pole (-) of the booster battery. Then connect the other end of the cable to a bolt on the clutch of the engine block.

⚠ DANGER

On an engine with a two pole electrical system, connect the other end of the jumper cable to the negative pole (-) of the booster battery.

3. Start the engine following the starting procedure.
4. Let the engine run at idle for few minutes to charge the battery.
5. Stop the engine and remove the cables in the exact reverse order from installation.

Panel with key

1. Move the control lever to the neutral position.
2. Push the manual stop control (if fitted).
3. Insert the key in the **ON/STOP** starter switch.
4. Turn the key a quarter-turn to the right. All the warning lamps come on and the acoustic alarm sounds. After a few seconds, only the **ENGINE OIL PRESSURE** and **BATTERY CHARGE LAMPS** remain lit.
5. Press the **START** button halfway to start preheating. Hold the button for 5 to 15 seconds, depending on ambient temperature to preheat the engine.
6. Press fully to start the engine. Once the engine has started, release the button, all lamps go out.
7. If the engine is fit with water cooled exhaust elbow, check that water flows from the exhaust outlet at the hull. If the water does not flow, stop the engine and check the raw water system.

Panel without key

1. Switch the key of the main panel to ignition (if equipped).
2. Move the control lever to the neutral position.
3. Push the manual stop control (if fitted).
4. Press the **ON/STOP** button. All the warning lamps come on and the acoustic alarm sounds. After a few seconds, only the **ENGINE OIL PRESSURE** and **BATTERY CHARGE LAMPS** remain lit.
5. Press the **START** button halfway to start preheating. Hold the button for 5 to 15 seconds, depending on ambient temperature to preheat the engine.
6. Press fully to start the engine. Once the engine has started, release the button, all lamps go out.
7. If the engine is fit with water cooled exhaust elbow, check that raw water flows from the exhaust outlet at the hull. If the water does not flow, stop the engine and check the raw water system.

During operation

⚠ **CAUTION**

Never press the **START** button when the engine is running.

Check the instruments and warning lamps after starting, and regularly when cruising.

Cruising speed

A recommended engine speed is given in the chapter **TECHNICAL DATA** to help you to set your cruising speed.

NOTICE: Always consider sailing conditions and load of the boat to set the cruising speed.

Operating the engine at wide open throttle should be avoided since it is both uncomfortable and uneconomical.

Note that operating the engine at a too low rpm for a long period could lead among other things to increased oil consumption.

Deposits may also form in the injection system if the engine do not reach its nominal operating temperature regularly. Run the engine at full throttle regularly in order to burn off any possible deposits in the fuel system.

Manoeuvring

⚠ **WARNING**

Shifting at high speed can damage both the engine and the transmission and be dangerous for passengers.

⚠ **CAUTION**

On a twin engine boat, both engines should be started during reversing manoeuvres to reduce the risk of water ingress in the stationary engine.

Carry out the following operations for forward / reverse manoeuvres:

1. Reduce engine speed to idling and, if possible, let the boat lose most of its speed.

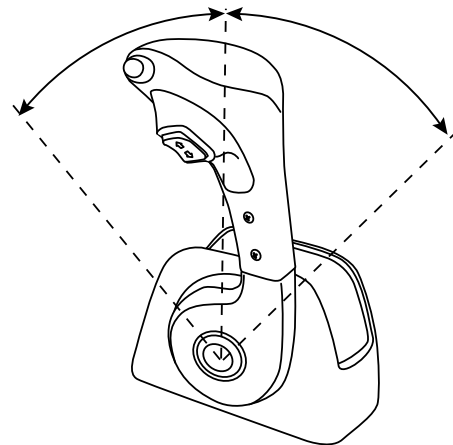

2. Move the control lever to the neutral position and wait a few seconds.
3. Move the control lever into astern. Increase the speed.

Sailing with the engine stopped

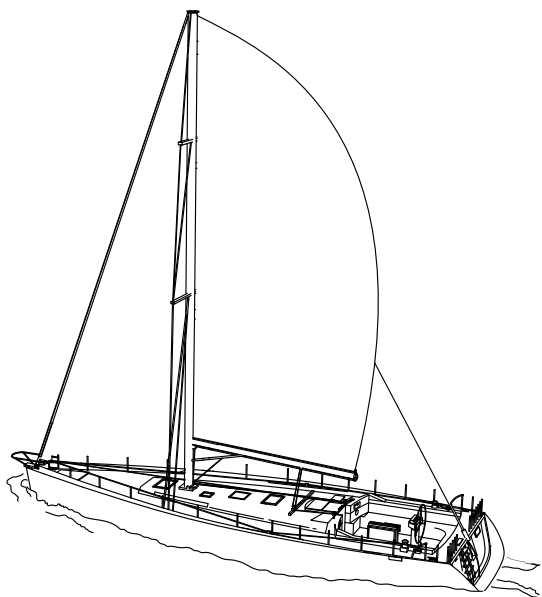

If the engine is fitted with a Sail Drive transmission **MODEL SP60**, when cruising under sail with the engine stopped:

If the blades of the propeller are foldable:

- Put the throttle lever astern (in reverse). The blades are closed when the boat moves forward. Hydrodynamic resistance created by the blades is minimized.

If the blades of the propeller are not foldable:

- Put the throttle lever astern (in reverse). The propeller does not rotate and create hydrodynamic resistance.
- Put the lever in neutral, the propeller rotate and create lower hydrodynamic resistance than in astern.

⚠ CAUTION

* Sailing with the engine stopped and the lever in neutral must not exceed 6 to 7 hours in a row. The propeller can drive the rotation of the shaft and damage the transmission. Run the engine for 15 minutes to lubricate the transmission at least every 6 hours.

* Whatever the type of propeller and transmission, never sail with the engine stopped in forward gear (in ahead).

* Under sail, close the seacock if the boat is able to reach a speed above 8 knots. Water can force one's way through the raw water intake and fill the exhaust system. Don't forget to open the seacock again before restarting the engine.



Stopping the engine

⚠ CAUTION

Never stop the engine by using the main switch. This could damage the electrical system.

Before stopping the engine, let it run at idle in neutral for few minutes, especially if the engine has been operated at high speed and load. This will allow the coolant to cool down the engine.

1. Start the fan in the engine compartment (if fitted) or open the hold.
2. *If the boat is fitted with a mechanical stop control:* Pull and hold out the stop command until the engine has stopped. Push the stop control. Turn the key on the panel counter-clockwise.
3. *If the boat is fitted with electric stop function:* Turn the key in the starter switch counter-clockwise, the engine stops and all indicators turn off. The engine stops, all lamps go out. For panel without key, press the **ON/STOP** button and release it. The engine stops. Turn the key of the main panel counter-clockwise. All indicators turn off.

⚠ CAUTION

Even after the engine has stopped, some components and fluids remain hot and pressurised for several minutes. As far as possible, limit work on the engine immediately after stopping it, when it is hot.

After the engine has stopped:

1. Switch off the main switch.
2. Close the sea cock and the fuel cock.
3. Inspect the engine compartment and check for any leaks.

⚠ CAUTION

* If the boat is being towed, stop the engine and close the sea cock to prevent the engine from being filled with raw water.

* On boats with twin engine, if cruising with a single engine, close the sea cock of the stopped engine.

Do not forget to open the sea cock before restarting the engine.

Anchoring

When the boat is at anchor or in port for extended period, vegetation may develop on the hull, the keel, the drive, the rudder, the propeller, etc. It will significantly affect the behaviour of the boat and the performance of the engine if the vegetation is not removed before the next time the boat is used.

Vegetation and fouling can also obstruct the raw water system and result in damage to the engine by overheating.

Inspect and clean the boat and the raw water system each time the engine is used. Clean if necessary. If the boat is put out of water, clean the hull and spray a coat of anti-fouling. Never paint the anodes.

Furthermore, when the boat is at anchor or in port for extended period, water can fill the exhaust system via the exhaust outlet. It is necessary to drain regularly the waterlock when the boat is at anchor.

Storage

If the boat is being left in the water while not in use for few weeks, the engine must be controlled and run few minutes every 10 days.

If the boat will not be used for more than 2 months, special set of operations must be performed on the engine and the transmission. Refer to the chapter **LONG-TERM STORAGE**.

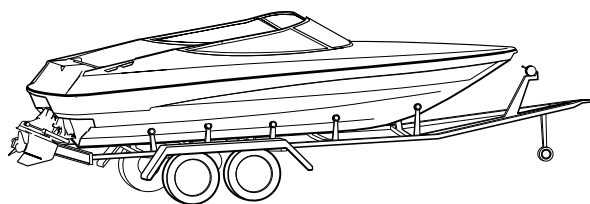

To prevent damages due to freezing, the cooling systems (raw water and coolant) must be drained when there's a risk a frost. Refer to the corresponding chapters in the section **MAINTENANCE** and to the chapter **LONG-TERM STORAGE**.

ALL THESE OPERATIONS SHOULD BE CARRIED OUT BY A NANNI AUTHORIZED WORKSHOP.



⚠ WARNING

* As far as possible, perform maintenance operations with the engine stopped, remove the key from the panel and turn off the power supply.

* Read this whole chapter and all safety precautions before starting any maintenance work. Make sure you understand how to perform every operation.

This manual only describe preventive maintenance operations to be carried out by the owner/operator of the engine. Carrying a set of preventive maintenance operations in accordance with the service intervals will ensure engine optimal reliability and service life.

During the warranty period, it is essential that all work is carried out by a Nanni authorized workshop. Furthermore, all servicing should be registered in the Nanni after-sale system.

However, some regular checks, particularly those made each time the engine is used, can only be carried out by the user. Few other operations are explained further on so that you can work on the engine in an emergency or if there is no repair centre nearby.

We recommend to have all your works checked by a Nanni authorized workshop.

Independent repair and adjustment work on the engine beyond a limited scope is forbidden for safety reasons.

Improper work endangers the person working on the engine and the others. Particularly operations on valve timing and injection system.

NOTICE: The service intervals and relevant informations concerning the preventive maintenance of the transmission are indicated in the user manual provided by the manufacturer of the transmission. Contact your Nanni dealer for further information regarding the maintenance of the transmission.

The hourmeter displays the operating hours of the engine.

Service schedule

NOTICE: An operation requiring service every day requires service after 100 hours or every year, and so on. Some components may not be part of the engine ordered.

Operations marked with ► should be done in a Nanni workshop.

* Operations to perform after 20 operating hours or 45 days after commissioning.

BEFORE OPERATING THE ENGINE

- Check the engine & transmission oil level. Top up if necessary *.
- Check the coolant condition and coolant level. Top up if necessary *.
- Check the raw water filter and clean as necessary *.
- Drain water from the fuel prefilter *.
- Check the condition of the battery *.
- Check the warning lamps of the instrument panel *.
- Control and adjust general water tightness *.
- Check the stuffing box condition *.

EVERY 100 OPERATING HOURS / AT LEAST EVERY YEAR

- Clean the air filter. Change if needed.
- Change the fuel filter *.
- Check the condition and the tension of the belts. Change if needed*.
- Check the anodes. Change if needed*.
- Check and tighten the electrical connections & cables, the clamps and screws *.
- Remove the sediment from the fuel tank and drain the fuel tank.
- Check the control unit, the condition of the cables, grease the cables *.

EVERY 200 OPERATING HOURS / AT LEAST EVERY YEAR.

- Change the engine and transmission oil *.
- Change the oil filters *.
- Change the fuel filters *.
- Check the raw water pump impeller. Change if needed.
- Check the engine flexible mountings. Adjust as necessary *.
- ▶ Clean the Turbo Wastegate.
- ▶ Clean and touch up the paintwork as necessary.

EVERY 400 OPERATING HOURS / AT LEAST EVERY 2 YEARS.

- ▶ Change the thermostat of the heat exchanger.
- ▶ Change the heat exchanger filler plug.
- ▶ Drain and change the coolant. Clean the coolant system.
- ▶ Check and clean the heat exchanger tube stack. Change the O-ring.
- ▶ Check and clean the air cooler tube stack. Change the O-ring. Check and clean the transmission oil cooler tube stack.
- ▶ Check the fuel injection nozzles. Change if needed.
- ▶ Check cold valve clearance.
- ▶ Check and clean the Turbo

General inspection

⚠ CAUTION

Do not let oil, fuel or grease deposits build up around the engine as they may increase the risk of fire in the engine compartment.

Make a habit of visually checking the engine and its compartment each time you operate the boat, before starting the engine: check for fuel, water or oil leaks, check the tightness of the different clamps and bolts, the condition of the belt, hoses and electrical wirings, the wear of anodes (if fitted) and the battery electrolyte level.

Control cables

The engine rpm and the gearbox shift command are controlled by mechanical control cables connected to the control lever.

Adjust the tension of the cable if necessary. If any defect appears (rust, crack, etc), the control cable must be changed.

Stuffing box

⚠ DANGER

A stuffing box lubricated with raw water taken from the engine cooling system must never be installed on a Sail boat or when the exhaust elbow is below the waterline. A separated water supply or a stuffing box lubricated by grease must be used on all Sail boat or when the exhaust elbow is below the waterline.

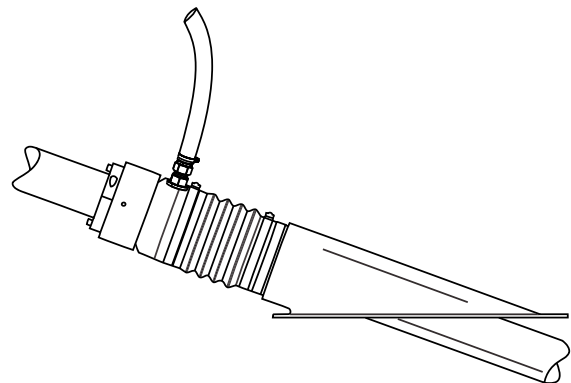

If the boat is equipped with a braided-type stuffing box, check the system's tightness. As this system is not absolutely tight, it is normal that a slight amount of water passes through the stuffing box. Correct operation is characterized by a drop-by-drop water intake. If too much water comes in, stop the engine and contact your Nanni dealer as soon as possible.

In any case, always make sure that the lubrication of the stuffing box is sufficient.

Exhaust system

Inspect all exhaust system components (hoses, clamps, mixing elbow, manifold, etc.) Check for cracks, leaks and corrosion. Tight or change them if necessary.

Check for carbon or soot residue on exhaust components as it indicates an exhaust leak.

If any defect appears on component of the exhaust system, change it as there's a risk of exhaust leakage or water penetration in the engine and the boat.

Air intake

⚠ WARNING

Carry out these operations when the engine is stopped and cold. Make sure that no dust or dirt enter the intake manifold.

The air filter reduces the level of noise made by the air intake and prevent particles from penetrating the intake manifold.

The reliability and the performances of the engine depend among other things on the quantity and the temperature of the intake air.

To check the air filter:

1. Remove the clamps and remove the filter.
2. Clean the inside of the filter with dry compressed air.
3. If the air filter is damaged, change it.
4. Install the filter with the clamps. Make sure the clamps are tight enough, while not damaging the filter.

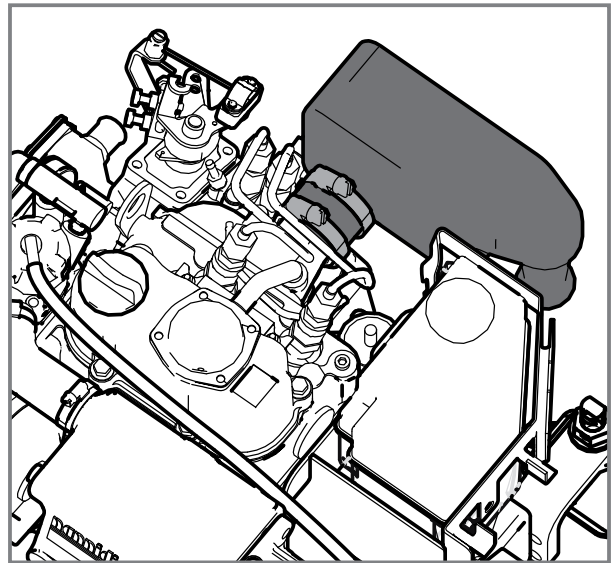

Fuel system

⚠ DANGER

* Stop the engine and let it cool down before refuelling or carrying out any operation on the fuel system.

⚠ WARNING

* Fuel is flammable and can be dangerous. Fuel spilled on hot surface or near spark can burn.

* Do not step on the injection pipes. Always make sure they are not damaged.

⚠ CAUTION

Total cleanliness must be guaranteed when working on the fuel system. No impurities should enter the injection system. Make sure not to spill fuel on hoses.

NOTICE: All work on the fuel injection system must be carried out by a authorized Nanni technician.

Check regularly the condition of the components of the fuel system (hoses, filter, clamps, etc). Change it if any defect appears.

Operation of the fuel system

The fuel is drawn from the tank by the fuel feed pump and is injected into the combustion chamber by the injection pump. A fuel filter is placed between the feed pump and the injection pump.

The injection pump delivers a larger amount of fuel than required for combustion. The fuel that is not burned is re-injected into the tank through an over-flow pipe.

⚠ CAUTION

The injection pump is an extremely precise unit. Water entry in the fuel system will cause major failure to the injection pump and to the whole fuel system.

A fuel prefilter with a water separator should be installed between the fuel tank and the fuel filter on the engine. The prefilter should be installed as close as possible to the engine fuel filter. It must never be installed on the engine as vibrations affect the water/fuel separation process.

If the fuel tank is located below the engine injection pump, an additional electric fuel feed pump should be installed between the prefilter and the feed pump of the engine.

Fuel requirements

Only use grade of fuels indicated in the chapter **TECHNICAL DATA**. Other grades of fuel can increase fuel consumption and cause operating problems, resulting in a shorter engine service life.

Use of fuel additives can result in poor performance or engine damage.

Before starting the engine, make sure that the fuel level is above the lower limit. If the fuel level is too low, add fuel to the upper limit. Do not overfill.

Use a strainer when filling the fuel tank. Dirt and dust in the fuel will cause trouble in the fuel injection system.

If the boat is not used for an extended period, fill the tank to the maximum level.

Fuel prefilter

The fuel prefilter is an optional extra not in the scope of supply of the engine. The model of prefilter can vary according the boat.

NOTICE: Drain the water in the prefilter several hours after the engine has been stopped.

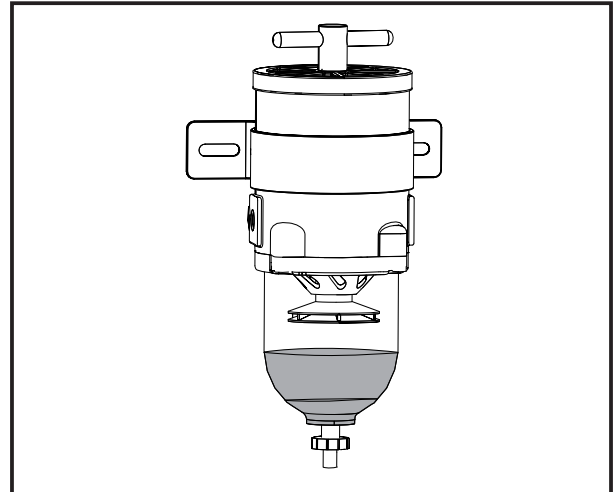

1. Close the fuel cock on the fuel tank.
2. Place a container under the fuel prefilter. Drain water and remove impurities using the cock/plug.
3. Tighten the cock/plug once the water has been drained.
4. Check the filtering element, change it if necessary.
5. Open the fuel cock.
6. If the filtering element has been changed, bleed the fuel system. Start the engine and check for leaks.

Replacing the fuel filter

NOTICE: Do not fill the new filter with fuel before assembly.

ENGINE MODEL N2.10:

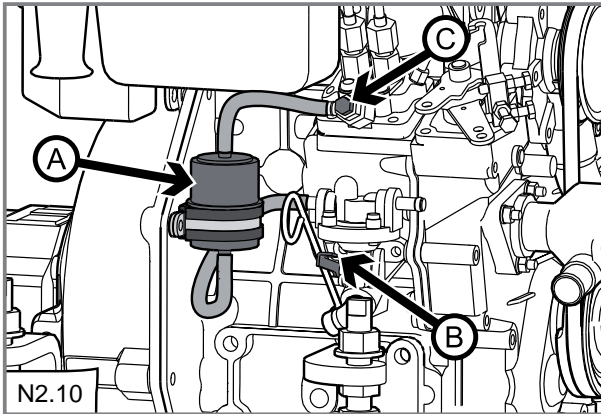

1. Close the fuel cock. Clean the filter bracket.
2. To avoid fuel leakage, clamp off the fuel supply line near the filter.
3. Disconnect the hoses. Clean-it.
4. Remove the fuel filter **A**. Put a plastic bag over the filter to prevent leakage on the engine.
5. Replace the fuel filter with the arrow on the fuel filter housing indicating the direction of fuel flow. Reconnect the pipes to the fuel filter.
6. Remove the clamps from the hoses.
7. Open the fuel cock and bleed the air in the fuel system.

ENGINE MODEL N2.14 & N3.21

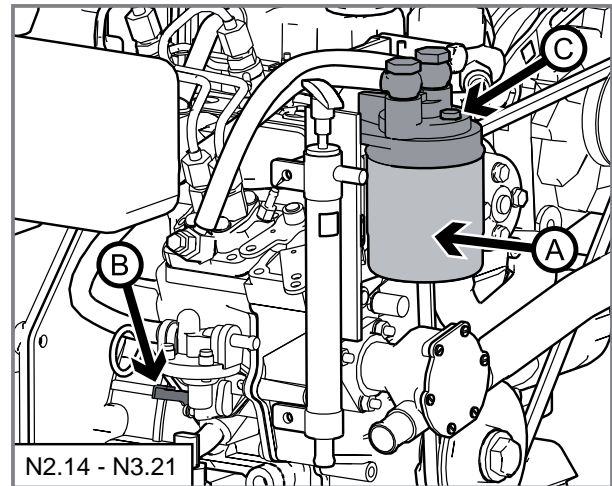

1. Close the fuel cock. Clean the filter bracket.
2. Put a plastic bag over the filter to prevent leakage on the engine.
3. Remove the fuel filter **A**. Use a filter wrench if needed.
4. Check and clean the sealing surface of the filter bracket. Apply film of fuel on the seal.
5. Screw the new filter by hand until the seal touch the matting surface. Screw a further half turn.
6. Open the fuel cock and bleed the air in the fuel system.

Air bleeding

Bleeding the air in the fuel system is necessary :

- After a maintenance operation on the fuel system.
- If the fuel tank has been emptied.
- The engine has not been started for a long time.

To bleed the fuel system **IF IT IS NOT FITTED** with an electric pump:

1. Fill totally the fuel tank. Open the fuel cock.
2. Loose the venting screw **C** . Use rags around the venting screw.
3. Pump the fuel using the lever **B** until fuel free of air bubbles flows from the venting screw.

NOTICE: If the lever is too hard to operate, turn the crankshaft a fraction of a turn.

4. Continue pumping and at the same time tighten the venting screw.
5. Pump few other times to prime the system.

To bleed the fuel system **IF IT IS FITTED WITH AN ADDITIONAL ELECTRIC FUEL FEED PUMP** :

1. Fill totally the fuel tank. Open the fuel cock.
2. Loose the venting screw **C** . Use rags around the venting screw.
3. Start the engine for 5 to 10 seconds to let the electric fuel feed pump bring fuel to the injection pump.
4. Pump the fuel using the lever **B** until fuel free of air bubbles flows from the venting screw.
5. Continue pumping and at the same time tighten the venting screw.
6. Pump few other times to prime the system.

CAUTION

Avoid draining all fuel in the filter



Lubrication system

⚠ DANGER

Carry out these operations with the engine stopped and cold. Remove the key and switch off the main switch to prevent accidental starting. Hot oil and hot surfaces can burn.

⚠ CAUTION

- * Never operate the engine if the oil crankcase has been over-filled. Drain the oil if too much oil has been added.
- * Observe the recommended type of oil for the transmission.

NOTICE: With a new or reconditioned engine, oil and oil filters must be changed after 20 hours of operation. Use oil grades quality indicated in the chapter **TECHNICAL DATA**. Warranty claims may be rejected if unsuitable oil grade has been used.

The viscosity may be adapted depending the climatic conditions.

Oil level- Adding engine oil

Check the engine and transmission oil level before starting the engine. Always make sure that the level is in the safe range.

The oil level should be within the range indicated on the dipstick, between the Mini and Max level.

To check the oil level:

1. Remove and wipe the dipstick.
2. Re-insert and remove the dipstick. Check that the oil level is between the Mini and Max mark.

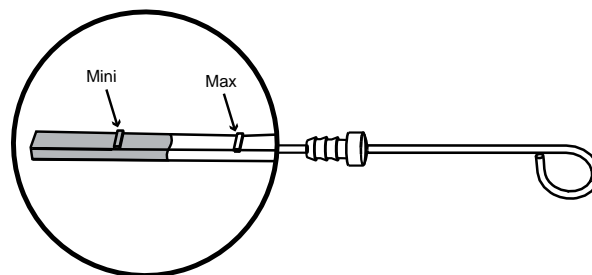

If the level is too low, remove the oil filler plug and add oil slowly. Wait few minutes before checking the oil level to let the oil drain down to the oil pan.

⚠ CAUTION

Do not fill the crankcase above the maximum level indicated on the dipstick. Do not operate the engine if the oil level is below the Mini mark or above the Max mark.

NOTICE: Completely drain the previous oil before adding new engine oil. Never mix different type of oil.

Draining the engine oil

1. Start the engine and let it warm few minutes so that oil suction is easier.
2. Stop the engine and remove the key from the panel.
3. Connect a disposal hose to the drain pump and place a container under the disposal hose.

NOTICE: On the engine model N2.10, the oil pump has to be connected to the dipstick port.

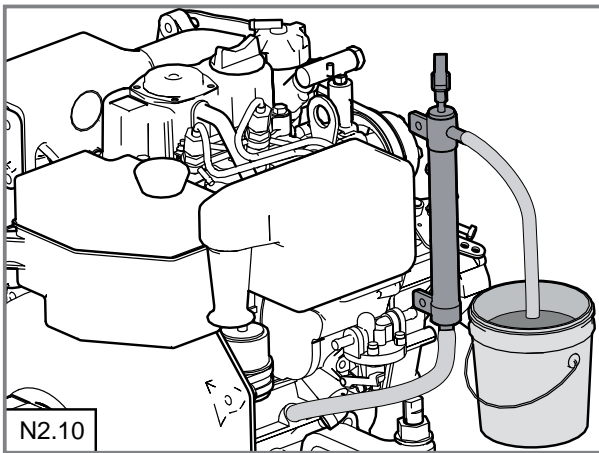

4. Suck out all the oil using the oil drain pump. Remove the drain hose and lock the pump.
5. For the N2.10, remove the oil pump and reinsert the dipstick.

Changing the oil filter

Change the oil filter each time the engine oil is drained.

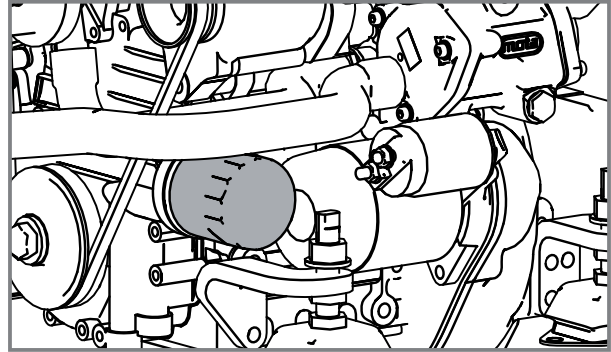

1. Remove the oil filter with a filter wrench. Turn the filter counter-clockwise. Remove the gasket.
2. Clean the mating surface in order to prevent impurities from entering the engine.
3. Apply a film of oil on the new gasket. Screw the new filter by hand with the new gasket. When the gasket contacts the mating surface, turn the filter a half turn.
4. Fill with correct amount of new oil. Check for leaks and check the oil level.
5. Start the engine and let it operate few minutes at idle. Check that the oil pressure warning lamp goes out.
6. Stop the engine, wait for the engine to cool down and check the oil level. Top up if necessary. ■

Cooling system

Overview

The cooling system cools the engine in order to maintain a proper operating temperature and prevent overheating. On some engines, the cooling system also cools the fuel, the oil or the intake air. The cooling system is made of two circuits:

- The **COOLANT CIRCUIT** which is the engine's internal cooling system. It's a closed-circuit in which coolant flows and cools the engine.
- The **RAW WATER CIRCUIT** which cools the coolant via heat exchange with raw water. Nanni engines comes as standard with an heat exchanger, in which the coolant is cooled by heat exchange with raw water taken from a sea cock. A Keel Cooling system can also be used to cool the coolant instead.

A thermostat maintains the coolant at a proper and constant operating temperature. With thermostat control, the coolant only enter the heat exchanger when the engine reach a certain temperature.

⚠ CAUTION

- * Engines with heat exchanger are not suitable for a Keel Cooling system.
- * Operating the engine without coolant or raw water supply, even for few seconds, will lead to complete engine failure.

Operation principle of the cooling system

Operation principle of an engine with heat exchanger:

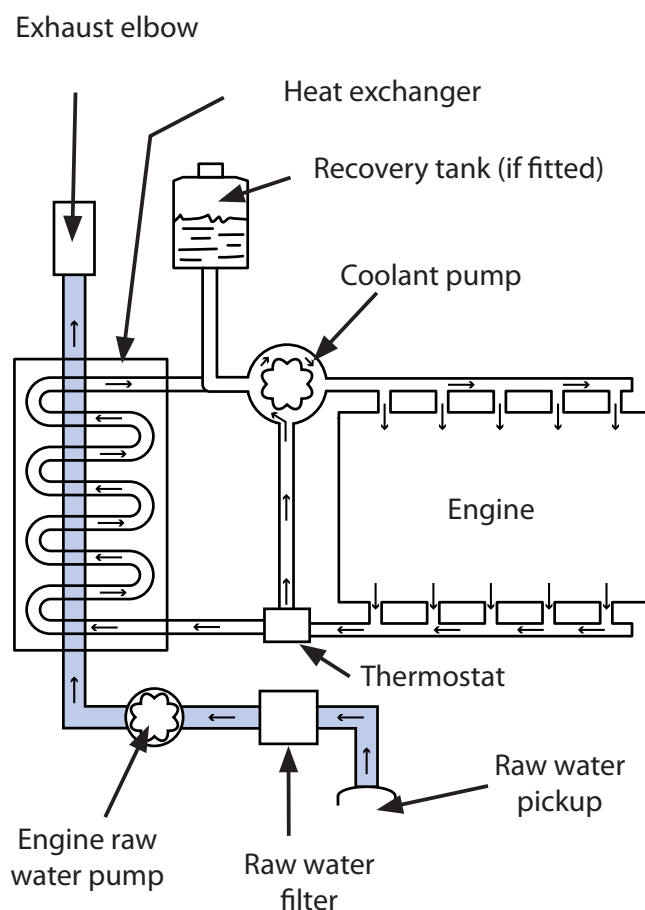

Coolant

⚠ CAUTION

* Always use coolant made of 50% antifreeze with anticorrosion additive and 50% of clean water. The antifreeze protects the engine against internal corrosion.

* This mix must be used all year around, even if there is no risk of frost.

* Never use water alone to completely fill the coolant system.

CLEAN WATER

Use clean soft water, distilled water or tap water to mix with antifreeze. Natural water generally contains minerals and sometimes salt, which can oxidize metal and accelerate corrosion process.

ANTI-FREEZE

Never use poor quality antifreeze. The main components of the anti-freeze can corrode metal, gathering rust in the cooling system over an extended period. Poor quality antifreeze has poor content of corrosion preventive. The content further becomes less potent with the dilution of water.

Choose additive that will not have any adverse effects on the materials of the cooling system. Never mix different additive as it may cause chemical reactions and therefore malfunctions.

WATER BOILER

A water boiler can be connected to the engine coolant circuit.

If the boiler is located above the engine, an additional recovery tank must be installed above the boiler.

The amount of coolant must be adapted depending the model of water boiler to completely fill the coolant system.

COOLANT EXPANSION

When it heats, the coolant expands and takes up a higher volume.

A recovery tank mounted on the engine allows to compensate this expansion.

⚠ CAUTION

The recovery tank mounted on the engine must never be moved from its original location without prior authorization from Nanni Industries S.A.S. France.

Coolant level

⚠ DANGER

Never open the coolant filler cap or any plug of the cooling system when the engine is operating or warm. Steam or hot fluid can spray out.

Always check the coolant level before starting the engine.

1. Stop the engine and remove the key from the panel.
2. Turn the coolant filler cap slowly to the first stop and let any pressure escape from the system then remove the cap.
3. Coolant level should lie between the filler neck lower edge and the level spur.
4. Top-up using clean water only.
5. Reinstall the coolant filler cap.
6. Check the coolant level in the recovery tank (if fitted). It should lie between the Min and Max mark of the recovery tank. Add clean water if necessary.

NOTICE: The Min and Max level indicated on the recovery tank (if fitted) does not indicate the correct level of coolant.

Draining the coolant circuit

1. Stop the engine and remove the key from the panel.
2. Put a container under the heat exchanger drain plug **A** to collect coolant.
3. Remove the cap **A** and the plug **B**.
4. Drain off all coolant. Drain off the recovery tank and the hoses.
5. Insert a hose into the heat exchanger filler port **B**. Rinse with fresh water until water which flows from the drain port **A** is clean.
6. Reinstall the drain plug **A** and fill with coolant to the correct level.

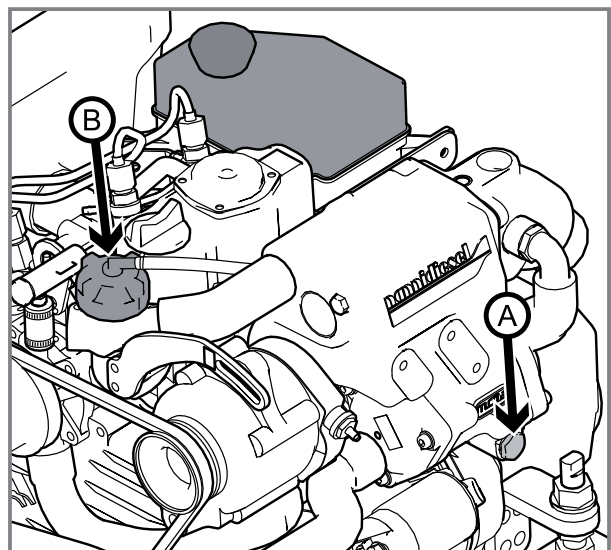

Coolant - Filling

Mix the anti-freeze with water in a clean container before filling the heat exchanger. The coolant must be totally free from dust. Fill the exchanger slowly not to introduce air into the coolant system.

Refer to the chapter **TECHNICAL DATA** to know the coolant capacity of the heat exchanger. For Keel Cooling system or when using a water boiler, the coolant capacity must be adapted according to the pipes length and the tank capacity.

To fill the coolant system :

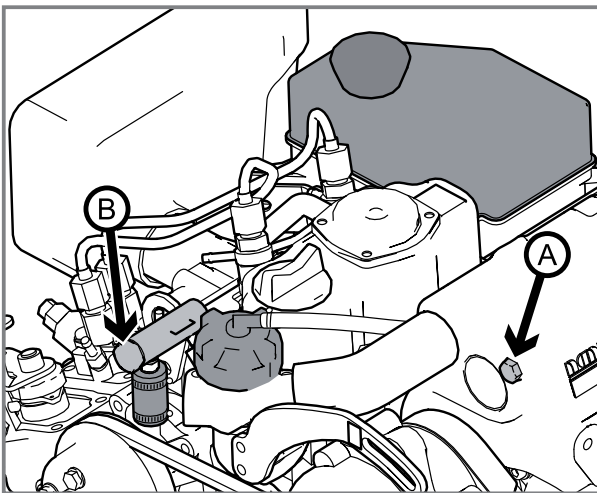

1. Remove the vent plugs **A** and **B**.
2. Remove the coolant filler cap and fill the exchanger with coolant.
3. Replace the vent plugs when coolant runs out from the drain openings.
4. Fill the exchanger with coolant to the correct level.

5. Replace the coolant filler plug and add coolant in the recovery tank if necessary.

6. Start the engine and let it operate few minutes at idle.

7. Stop the engine. Wait few minutes and check the coolant level. Top up if necessary.



Raw water system

⚠ DANGER

When the boat is in the water, water can flow into the boat via components located below the waterline. Close the raw water cock (if fitted) or prevent water discharge before working on this raw water system.

The raw water system allows to cool the engine coolant and the exhaust gas.

Raw water is drawn into the heat exchanger by the raw water pump of the engine. The raw water is discharged via the exhaust elbow, where it is mixed with exhaust gases.

Engines designed for a Keel Cooling system are generally not fitted with raw water system components (raw water cock, heat exchanger, etc). In Keel Cooling system, the coolant heat is dissipated by passing through tubes incorporated to the hull.

NOTICE: If there's any risk of frost, raw water system should be drained.

Siphon breaker

⚠ DANGER

Close the sea cock before any operation on the siphon breaker.

NOTICE: The use of a siphon breaker is mandatory if the exhaust elbow is under the waterline at full load or at less than 200 mm above it. A siphon breaker is mandatory in all Sail Boat and when there's a risk of water entry in the engine.

The siphon breaker prevents raw water entry into the cylinders via the raw water/exhaust system.

To operate correctly, the siphon breaker should clean twice a season, or when leakage appears.

⚠ CAUTION

A faulty operation of the siphon breaker will lead to water entry in the engine.

Inspect it regularly and clean it following the instructions given by the manufacturer.

Raw water pump impeller

⚠ CAUTION

If the engine has been run without supply of raw water, check the raw water pump impeller. Change it if needed.

The raw water pump impeller is an essential component of the engine. It should be changed regularly along with the seal. A worn impeller could crack and damage the cooling system. Always have a spare raw water pump impeller on board.

NOTICE: The service life of the raw water pump impeller vary depending the operating conditions.

To extract the impeller:

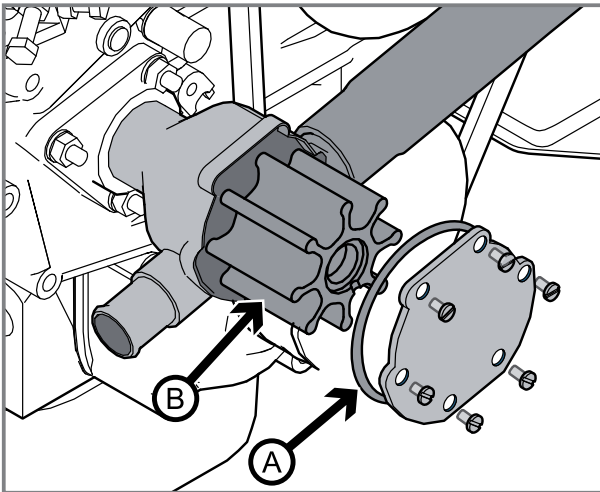

1. Stop the engine, remove the key from the panel and close the sea cock.

2. Remove the cover of the raw water pump.

3. Remove the gasket **A**.

4. Mark the position of the neoprene impeller **B** inside the pump in order to install it in the correct position in case of reinstallation.

5. Carefully remove the impeller using an extractor.

6. Inspect the impeller. Check for damaged, cracked, broken missing or flattened vanes. Change the impeller if it is damaged. Clean and drain the raw water system if parts of the impeller are missing.

7. Inspect the cover and the gasket for corrosion or damage. Change it if they are damaged.

8. Lubricate the inside of the pump and the cover with waterproof grease for rubber.

9. Install the impeller. If reinstalling the old one, place it at the same location using the mark done previously. Rotate the impeller in the same direction as the engine rotation. Lubricate the impeller with waterproof grease for rubber.

10. Install the gasket and the cover on the pump housing.

11. Open the sea cock, check for leaks. Prime the raw water system by adding water through the raw water filter if necessary.

12. Start the engine and check for leaks.

Cleaning the raw water filter

A raw water filter must be fitted between the raw water intake and the raw water pump of the engine.

The model of prefilter can vary according to the boat as the raw water filter is an optional extra not in the scope of supply of the engine. These instructions are given as an example only.

Check the raw water filter more regularly than indicated in the service schedule if the boat is used in water with a lot of dirt and/or mud.

To clean the filter:

1. Stop the engine, remove the key from the panel and close the sea cock.
2. Check the condition of the raw water filter. If deposits have formed, screw off cover and remove seal plate.
3. Remove all the contaminants. Rinse the filter and the housing with fresh water and check the condition of the seal.
4. Reinstall all the components and open the sea cock. Start the engine and check for leaks.

NOTICE: When the boat is out of water, check that the through-hull is not obstructed by mud or algae.

Raw water system - Draining

WARNING

It is highly recommended to carry out these operations when the boat is laid up on land. If the boat cannot be removed from the water, close the sea cock and prevent water entry by any means.

1. Stop the engine, remove the key from the panel and close the sea cock.
2. Remove the cover of the raw water pump.
3. Remove the cover and the seal from the raw water filter.
4. If a siphon breaker is fitted, drain it following the manufacturer's recommendations.
5. Drain the cooling system of the transmission lubrication circuit (if fitted).
6. Drain the waterlock and any other equipment connected to the raw water and exhaust system.
7. Reinstall correctly all components. Open the sea cock and check for leaks. Prime the raw water system by adding water through the raw water filter if necessary.

Raw water system - Cleaning and inhibiting

The raw water system must be flushed with fresh water to prevent the buildup of deposits and salt crystals in the circuit. It must also be protected against corrosion and frost when performing long-term storage.

1. Stop the engine and close the sea cock.
2. Disconnect the hose on the outlet side of the raw water filter.
3. Place the free hose in a container filled with fresh water. Ensure the tank is large enough as the raw water pump must never be run without water.

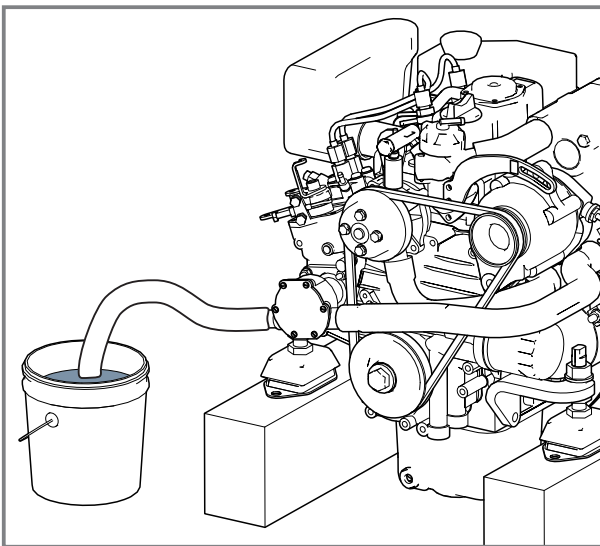

4. Check that no one is in the vicinity of the engine, the propeller and the exhaust outlet. Put the lever in neutral and start the engine.
5. Let the engine run few minutes at idle. Add fresh water in the container if necessary.

6. Stop the engine.
7. Fill the container with engine coolant mix (50% clean water, 50% anti-freeze).
8. Start the engine and let it run at idle. Add enough coolant to fill the raw water system with coolant.
9. Stop the engine before the container is empty.
10. Reconnect the hose.
11. Drain the coolant before the next time the engine is used.

⚠ WARNING

Check for leaks before the next engine start.

⚠ CAUTION

When preparing the engine for long term storage, if the engine is likely to be subject to frost, drain all water and coolant in the cooling systems.

Electrical system

⚠ DANGER

Stop the engine and switch off the main switches to break the current before working on the electrical system. Isolate shore current to any accessories mounted on the engine.

⚠ CAUTION

The main switch should always be switched ON when the engine is operating. Never disconnect the lead between the alternator and the battery when the engine is operating.

Wires and connectors

Check that electrical wires and connectors are dry and in good conditions.

The engine extension harness should be away from any water projection and must be correctly attached as high as possible in the hold. Change it if any defect appears.

Tighten the cable terminals and lubricate them with appropriate grease.

Fuses

The engine electrical system is protected from electrical overload damage by fuses.

If the electrical system does not work, the engine does not start or the instruments panel don't operate, a fuse may have trip.

Investigate the cause before resetting the fuse. Always have spare fuses on board. Replace a blown fuse with one of the same rating.

⚠ CAUTION

If the replacement fuse blows, this indicates an electrical problem. Don't start the engine, except in case of emergency, and contact a Nanni workshop.

Boats with metallic hulls

Engines in metallic hulls are generally fitted with a two-pole electrical system. This system allows to electrically isolate the engine from the electrical ground of the boat.

Contact your Nanni dealer for more informations.

Battery

⚠ DANGER

* Never touch the battery electrolyte. The diluted sulphuric acid solution burns skin and make holes in clothing. Should this occur, immediately wash it off with plenty of clean water and obtain medical assistance without delay.

* Disconnect the battery leads before carrying out any soldering work on metallic hull.

Always read the manufacturer recommendations before operating the battery.

Battery should be kept clean and dry. Oxidation or the deposit of impurities on the battery and on its terminals may lead to short circuits, voltage drops and premature discharging, notably in wet weather. Use a brass brush to clean battery terminals.

When **DISCONNECTING** the cables, always disconnect **FIRST** the **NEGATIVE LEAD (-)**, and then the **POSITIVE (+)**.

Always **CONNECT FIRST** the **POSITIVE LEAD (+)** to the **POSITIVE TERMINAL (+)** of the battery, and then the **NEGATIVE (-)**.

Use distilled water to top up the electrolyte level. Follow in priority the battery manufacturer instruc-

tions for topping up. If the battery electrolyte level is not adjustable (maintenance free battery type), do not use or charge the battery if the fluid level stands below the lower limit level.

When adding electrolyte, unscrew the vent plugs but leave them in their holes.

⚠ DANGER

Check that the battery compartment is well drained and ventilated. When charging, battery produces hydrogen which is extremely explosive.

If the battery is replaced, use a battery with similar specifications to the previous one.

To simultaneously charge tow independent battery with a single alternator, an isolator is available as an option on most engines. Contact an authorized Nanni dealer.

BATTERY STORAGE

When storing the engine, adjust the battery electrolyte level and store it in a dry place. Recharge the battery as often as possible to extend its service life.

Alternator belt

⚠ DANGER

Stop the engine and remove the key before servicing the alternator belt.

Always keep a replacement belt on-board.

The alternator belt drives both the coolant pump and the alternator. Additional belt can also be fitted.

A loosen or damaged belt can result in overheats or insufficient alternator charging. A belt that is too tight can damage the bearings in the pump and the alternator.

Visually check the belt for excessive wear, frayed cords, etc. If any defect has been found, change the belt. Check that it fits properly in the pulley.

Also check its tension. The deflection must be of between 8 to 10 mm when pressing the belt with the hand between two pulley when the belt is warm.

To adjust the belt tension:

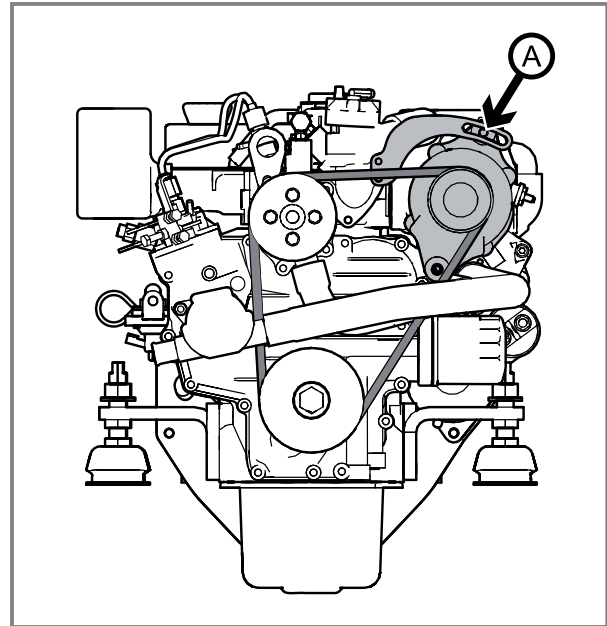

1. Stop the engine and remove the key from the panel.
2. Loosen the alternator mounting bolt **A** and pull the alternator out until to adjust the deflection of the belt.
3. Tighten the alternator mounting bolt.
4. Check the tension after few hours of operation.



Corrosion protection

The engine and all metal item in the boat that are exposed to water or damp can be damaged by corrosion.

There are two main categories of corrosion, which can be cumulative: galvanic corrosion and electrolytic corrosion. Both corrosion processes are a result of electric current that flow between metal items in an electrolyte such as water.

Galvanic corrosion

Galvanic corrosion is an electrochemical reaction that create electrical current between dissimilar metals exposed to water. This current will corrode the more anodic metal.

Several factors, cumulative or not, can worsen this effect:

- High saline and/or mineral concentration in water.
- High water temperature (>25°C).
- When cruising at high speed or when there's a strong current.
- Important relation difference between the cathode and anodic surfaces.

Anodes in magnesium or zinc are generally used to protect the boat against galvanic corrosion. Due to their intrinsic nature, these anodes

will wear down in place of other metallic components.

During the first year of use, check the anodes deterioration every 3 months. During prolonged mooring near other boats or dock side, control the wear and tear of the anodes at shorter intervals. In that case, the use of additional corrosion protection might be necessary during prolonged mooring.

Depending upon operating conditions and water properties, it might be necessary to check and/or replace the anode more frequently.

CAUTION

The anodes must never be painted or damaged. They must be changed as soon as they are corroded of more than 50%.

Electrolytic corrosion

Electrolytic corrosion is caused by externally generated DC electrical currents that pass through a metal item to another in an electrolyte such as raw water. Electrolytic corrosion is especially due to circuit leakage currents, shore power systems or DC ground faults.

The consequences are the same as galvanic corrosion. However, the protective measures against galvanic corrosion are only partially effective against electrolytic corrosion.

To protect the engine against electrolytic corrosion, the following recommendations should always be followed:

- Electric cables must never be exposed to water or damp. They must be clamped and free from any mechanical constraints.
- If the boat is connected to shore power, the protector ground must never be in the boat. Shore power should always have a ground fault circuit breaker.
- Shore power units must be intended for marine usage.
- All equipment fitted with a protective ground terminal, the engine along with the anodes must be connected to the common ground of the boat.

DANGER

For engine with a two-pole electrical system, the negative pole of the battery must never be connected to the common ground of the boat.

CAUTION

The Sail Drive model SP60 is electrically isolated from the engine. Never connect the Sail Drive SP60 to the common ground or to any metal item or electrical equipment.

- A main switch must be connected to the positive circuit (+) of the battery. This switch must be switched off when the boat is not in use to cut off the power to all equipment.

WARNING

Never switch off the power of a corrosion protection system powered by a battery.

Engine anode

In order to protect the engine and its raw water system from corrosion, the engine is fitted with a zinc anode.

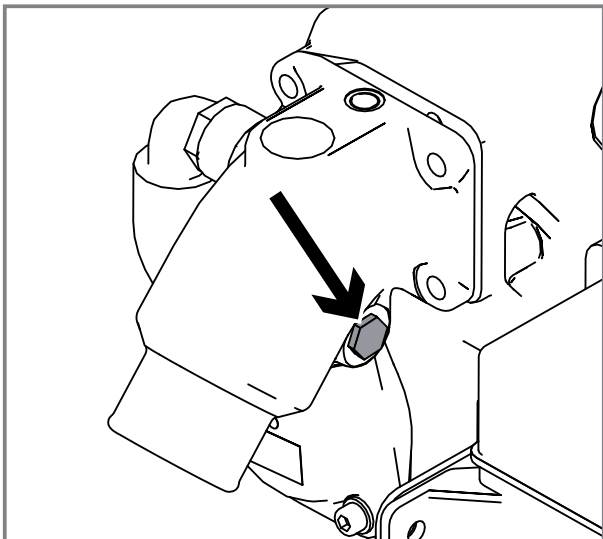

Intervals given in the service schedule are recommendations. Depending upon operating conditions and raw water properties, it might be necessary to check and/or change the anode more frequently.

To remove the anode:

⚠ WARNING

Carry out these operations when the engine is stopped and cold.

1. Remove the key from the panel.
2. Close the sea cock.
3. Drain the raw water system.
4. Remove the set formed by a cap, a seal and the anode.

5. Remove the deposits from the surface of the anode using glass paper before determining the level of erosion. Do not use a soft steel brush as this could leave deposits that are likely to speed up corrosion.

6. If more than 50% of the anode has been used up, change it along with the seal.

The length of a new anode is 16 mm.

⚠ CAUTION

Screw the anode cap back on tightly and do not forget to re-open the sea cock.



Long term storage

A set of operations must be performed to prepare and protect the engine for a long-term storage.

Refer to the corresponding chapter in the **MAINTENANCE** section to perform some of these operations. We recommend that you have all these operations carried out by a Nanni authorized workshop.

NOTICE: It might be necessary to adapt these operations depending the climatic conditions. Contact a Nanni authorized workshop for further informations.

For prolonged storage (>12 months), a specific set of measures must be performed. All these operations should be carried out by a Nanni authorized workshop.

CAUTION

* If the engine is likely to be subject to frost, drain all coolant and water in the coolant and seawater circuits. Indicate by any means that there is no coolant in the engine.

Long term storage procedure

Complete the nearest periodic maintenance inspections and operations before performing the long term storage procedure.

1. Drain and change the engine and transmission oil.
2. Change the engine oil filter.
3. Change the fuel filter and pre-filter.
4. Run the engine to normal operating temperature.
5. Stop the engine and take the boat out of water.
6. Drain, clean and inhibit all components of the seawater system.
7. Remove the impeller from the seawater pump (if fitted). Store it in a cool and dry place. Indicate by any means that the impeller has been removed.
8. Check the engine coolant level and condition. Top up if necessary.
9. Drain any water and contaminants from the fuel tank.
10. Fill totally the fuel tank.
11. Remove the air filter. Secure all air intake with clean clothes.
12. Clean the engine. Repair any damaged areas of paintwork with Nanni original paint.

⚠ CAUTION

Do not point a high pressure water jet toward seals, hoses, grommets, etc.

- 13.** Clean the hull, the hold and the drive (if fitted).
- 14.** Check all control cables. Use grease and rust inhibitor to protect the cables.
- 15.** Disconnect battery leads. Adjust electrolyte level if necessary. Charge the battery. Store the battery in a dry place.
- 16.** Release belts tension.
- 17.** Spray the engine with water-repellent product.
- 18.** Remove the propeller for storage. Check the overall condition of all components of the propulsion system.

Restarting the engine

- 1.** Perform external cleaning of the engine and control its condition.
- 2.** Drain and change the engine and transmission oil.
- 3.** Change oil filters.
- 4.** Drain the coolant from the seawater system.
- 5.** Check the condition of the raw water pump impeller. Change it if needed. Install the impeller.

- 6.** Remove cloth and tape from openings. Install the air filter.
- 7.** Close/Tighten all plugs and drain cocks.
- 8.** Check the condition of hoses and clamps.
- 9.** Check the engine coolant level and its condition. Top up if necessary.
- 10.** Connect fully charged batteries.
- 11.** Check the anodes.
- 12.** Install the propeller.
- 13.** Check the operation of the control cables and their condition.
- 14.** Check belts. Adjust the tension.
- 15.** Bleed the fuel system.

Once the boat is in the water:

- 16.** Open the sea cock and prime the seawater system (if fitted).
- 17.** Start the engine. Check for leaks and correct operation.



8

TROUBLESHOOTING

If the engine does not function properly, use the following chart to identify the cause. If the cause of trouble can not be found, contact a Nanni authorized workshop.

NOTICE: Some components may not be part of the engine ordered. This list is not exhaustive and is only an assistance in case of emergencies.

	PROBABLE CAUSES
The engine fails to start	1, 2, 3, 4, 5, 6, 7, 8, 9, 10, 11, 13
The engine starts but suddenly stops	1, 2, 3, 4, 5
The engine is difficult to start	1, 2, 3, 4, 5, 6, 8, 9
The starter motor is not turning or turn slowly	8, 9
The starter motor turns but the engine does not start	1, 2, 3, 4, 5, 6, 7
The engine does not reach its rated speed at wide open throttle	2, 3, 4, 5, 6, 7, 12, 14, 15, 16, 17, 26, 28
The engine operate unevenly	1, 2, 3, 4, 5, 6, 7, 14, 15, 16, 17, 18, 19, 20, 24, 28
The engine vibrates a lot	16, 27
Black exhaust smoke	4, 5, 14, 15, 16, 19, 20, 28
White exhaust smoke	4, 5, 23, 25
High fuel consumption	4, 7, 14, 15, 16, 19, 20, 22, 28
The engine overheats / coolant temperature too high	14, 15, 16, 18, 19, 20, 21, 22, 28
The control lever is hard to operate	12, 14, 15, 16, 17, 26
No shift between ahead and astern	9, 11, 12, 16, 17, 26
Battery charge warning lamp comes on	8, 9, 11, 18

The numbers refer to the possible causes indicated on the following page. *
Contact a Nanni authorized workshop.

1. Lack of fuel
2. Air in fuel system
3. Fuel filter fouled or clogged
4. Fuel do not meet specified standard
5. Water/contaminants in fuel
6. Valve clearance is wrong *
7. Low compression *
8. Insufficient battery charge / Defective battery
9. Faulty electrical cables contact
10. Faulty starter or starter switch *
11. Tripped fuse / Main switch is open
12. Transmission is damaged*
13. Control lever not in neutral / Stop control pulled out
14. Too much load on board
15. Fouling on underwater hull, drive or propeller
16. Defective/incorrect propeller *
17. Faulty operation of control lever / control cables
18. Loosen or damaged belt
19. Incorrect coolant / Low coolant level / Coolant leaks
20. Cooling system does not operate correctly *
21. Faulty thermostat *
22. Sea cock valve closed / Raw water filter clogged
23. Lube oil burns. Excessive oil consumption *
24. Engine oil level too low
25. Engine oil level too high
26. Transmission oil level too low
27. Defective engine mounting *
28. Insufficient air supply *



MODEL	N2.10	N2.14	N3.21
ENGINE CHARACTERISTICS			
Type	4 strokes Diesel		
Max. power - kW (hp)*	7.36 - 10	10.3 - 14	15.4 - 21
Number of cylinders / Arrangement	2 in line	2 in line	3 in line
Displacement (cm ³)	479	479	719
Bore and stroke (mm)	67 - 68		
Air intake	Natural		
Compression ratio	23.5:1		
Idle speed - clutch disengaged (rpm)*	1050	1050	1050
Rated engine speed @ Max power (rpm)*	3000	3600	3600
Max RPM at wide open throttle (rpm)*	3220	3820	3820
Recommended cruising speed (rpm)	2400 ~ 2700	2880 ~ 3240	2880 ~ 3240
Weight without gearbox (kg)	78	83	97
Valve clearance (engine cold) - intake (mm)	0,145 ~ 0,185		
Valve clearance (engine cold) - exhaust (mm)	0,145 ~ 0,185		
Direction of rotation, view from flywheel	Counter clockwise		

MODEL	N2.10	N2.14	N3.21
ELECTRICAL SYSTEM			
Recommended starter battery capacity (Ah)	35 ~ 50		
Starter (kW)	0.8		1.0
Standard Alternator (V-A)	12 - 40	12 - 70	12 - 70
FUEL SYSTEM			
Injection system	Indirect (E-TVCS)		
Injection timing before TDC (°)	21		
Fuel injection pressure (bar)	137.3		
Specific fuel consumption (g/kWh) at wide open throttle	265	285	285
Fuel requirements	EN 590 / ASTM D975 No.2-D Never use fuels that have sulfur content greater than 1.0 %		
LUBRICATION SYSTEM			
Oil quality	API CF mini		
Oil viscosity (temperate climate)	SAE 15W40		
Engine oil capacity - no engine inclination (litre)	2.1	2.1	3.3
Min oil pressure at rated rpm (bar)	3.5	3.5	3.5
COOLING SYSTEM			
Coolant capacity - no engine inclination (litres)	2.7	2.7	4
Coolant pump flow rate at rated rpm (l/min)	23	28.8	35.5
Raw water pump flow rate at rated rpm (l/min)	15	18	18



NANNI INDUSTRIES SAS

11, Avenue Mariotte-Zone Industrielle

33260 La Teste France

Tel: + 33 (0)5 56 22 30 60

Fax: +33 (0)5 56 22 30 79

Email: contact@nannidiesel.com

www.nannidiesel.com

P/N 970316081
082013.IndA